

Welcome to ICC Sydney Venue Plans. Navigate through the venue’s rooms to find information relating to layouts, rigging, pits and floor boxes and projector locations.

This document is an interactive PDF to help you find the information you require. It is a large document, therefore a high speed connection is essential.

The document is organised by venue, level, room and setup mode:

- ① Simply proceed to the venue of your choosing by clicking the buttons from the top menu bar on this page.
- ② To navigate further, select the level of the room from the venue’s home page, followed by the selected room and finally the setup mode from the bottom menu bar.
- ③ The arrows in the top right corner appear on every page and can take you back and forward, or simply select a venue from the top menu to start over and be directed back to the venue home page.
- ④ Clicking on the [i] symbol in the top right corner will take you back to this page.

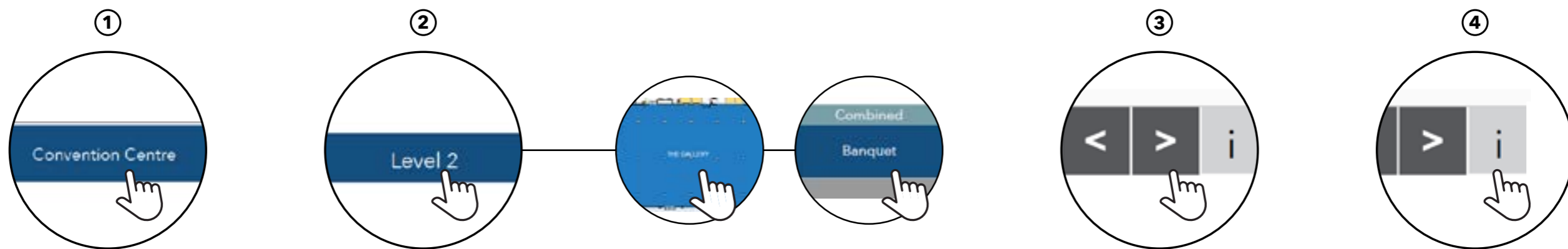

Improve on-screen appearance:

Ensure you zoom in or out to fit the content on your screen proportionally, as required buttons are located at the top and bottom of the document.

This document is a guide only, for further enquiries please call + 61 2 9215 7100 or visit us at iccsydney.com.au.



ICC Sydney Theatre

Entry from Tumbalong Boulevard up to Main Foyer, VIP entrance, General Admission Entrance, Box Office.

Main Foyer

Function Area

Mid Foyer

Upper Foyer

Seating Plans

Sections



Car Park P1 and pedestrian access to Tumbalong Boulevard

Exhibition Centre - halls 1 - 4

Concourse Level, registration and access for halls 1 - 4

Meeting Rooms E3.1 - E3.10 and Business Suite 3

Exhibition Centre - halls 5 - 7 and the Event Deck

Meeting Rooms E5.1 - E5.10

Sections through Exhibition Centre



Main entry to ICC Sydney Convention Centre, covered drop off, registration and Speakers' Preparation Room

Business Suites 1.1 - 1.5 and VIP Boardroom

Concourse level, The Gallery, Parkside Ballroom, Pyrmont Theatre, Meeting rooms C2.1 - C2.6,
Business Suites 2.1 - 2.3, accessible entry to Darling Harbour Theatre

Cockle Bay Room, Meeting Rooms C3.1 - C3.6, entry to Darling Harbour Theatre

Meeting Rooms C4. 1 - C4.11 and entry to Darling Harbour Theatre

Grand Ballroom

Darling Harbour Theatre - capacity 2,500

Pyrmont Theatre - capacity 1,000

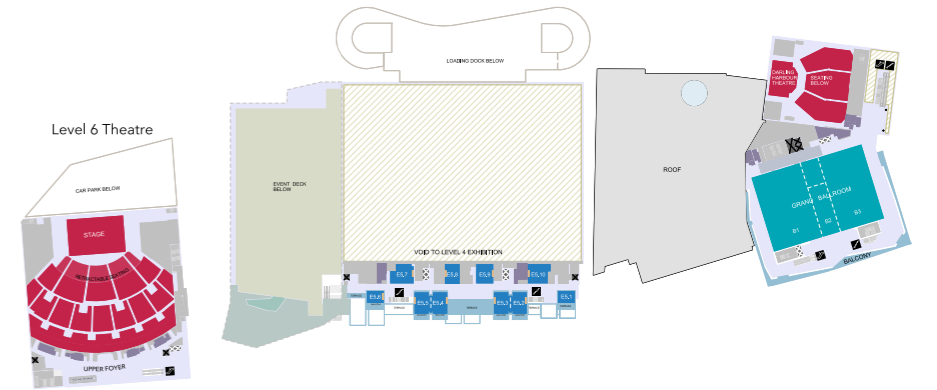
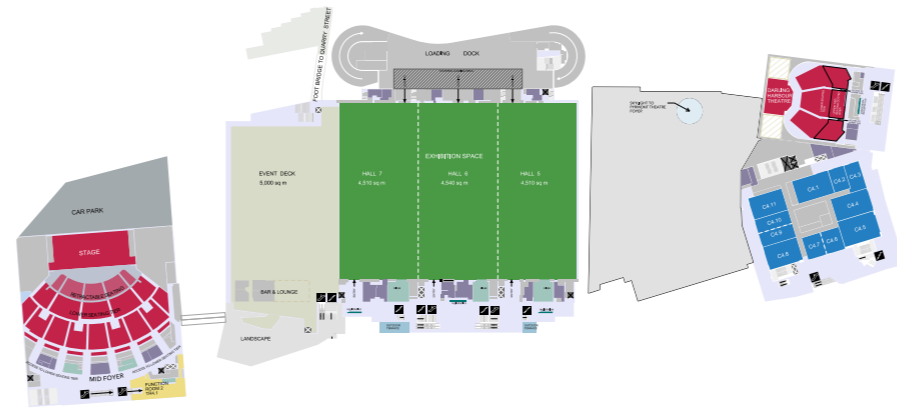
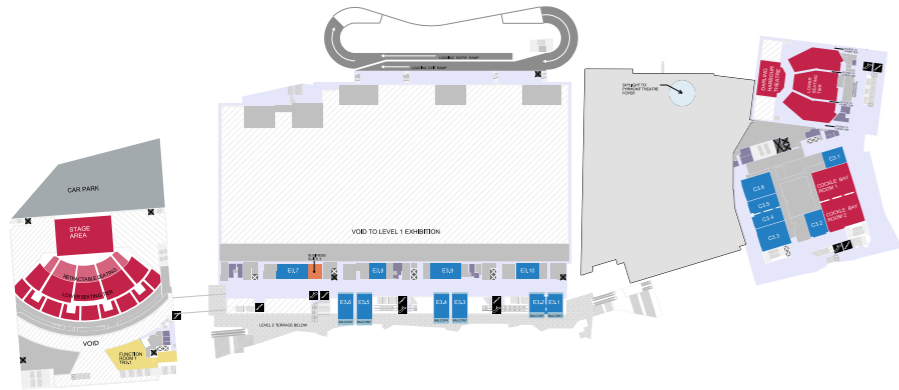
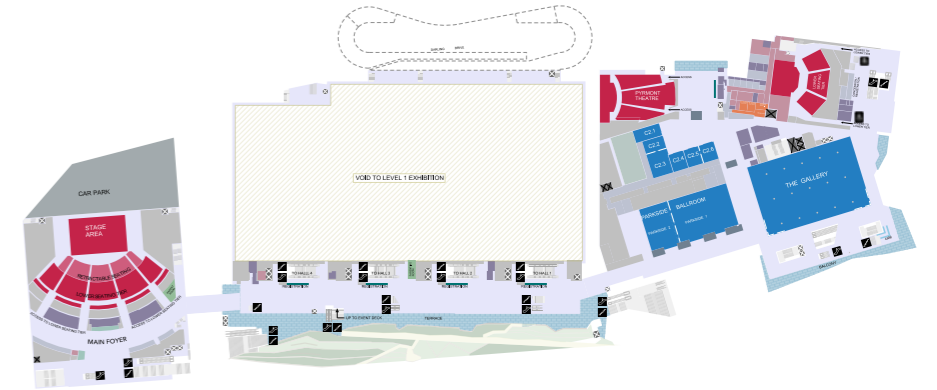
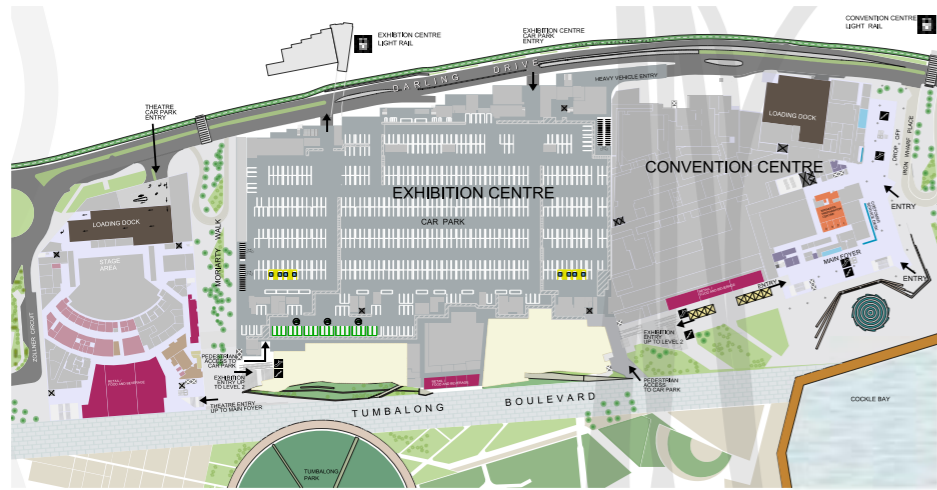

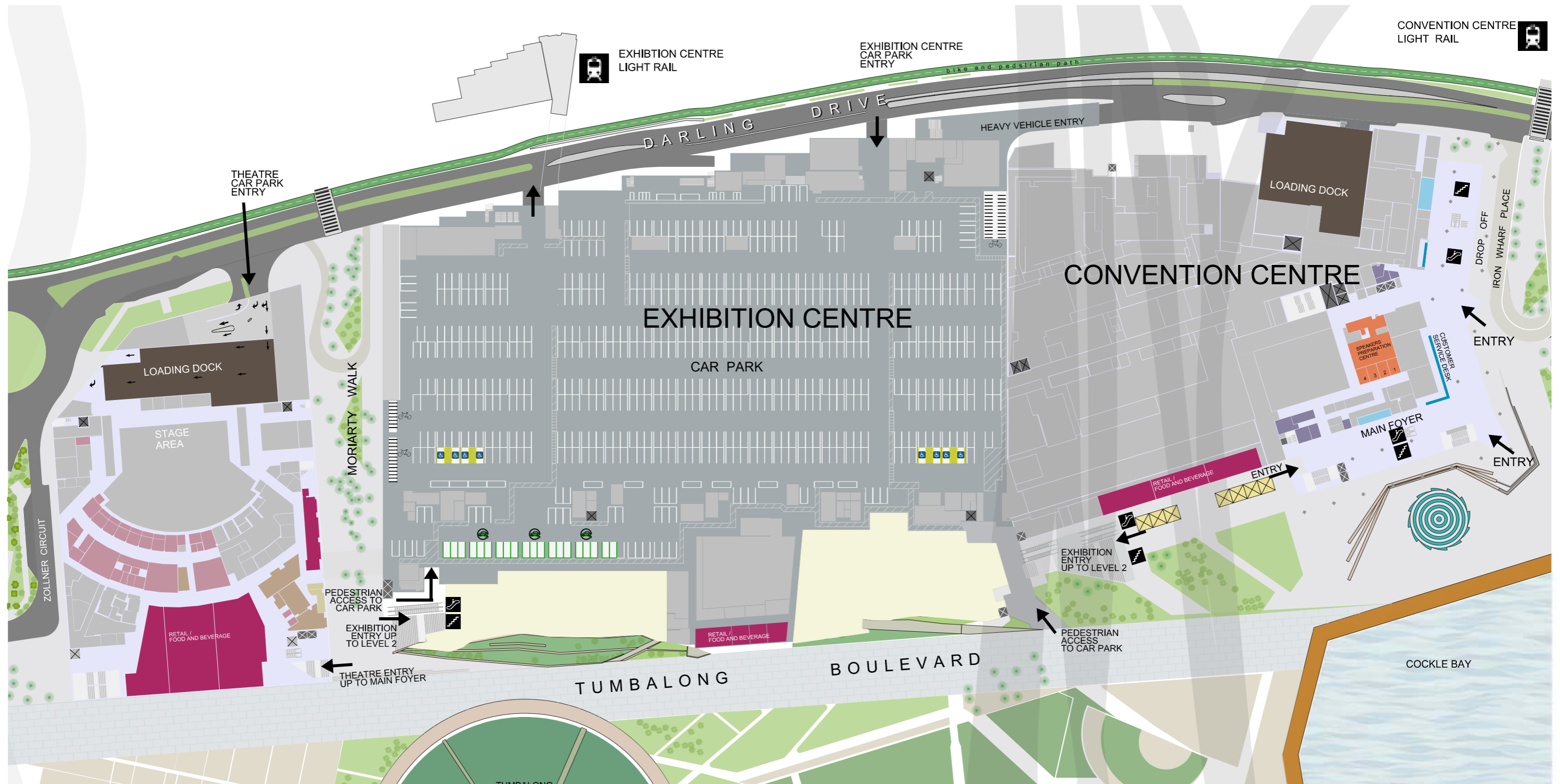

GROUND LEVEL

- | | | | | | |
|--------------------------------------|----------------------------|---------------------------------|-----------------------|-----------|-------------|
| CIRCULATION | TOILETS | SPEAKERS PREPARATION CENTRE | THEATRE VIP AMENITIES | STAIRS | PUBLIC LIFT |
| REGISTRATION / CUSTOMER SERVICE DESK | RETAIL / FOOD AND BEVERAGE | THEATRE GREEN ROOMS / AMENITIES | CAFE | ESCALATOR | GOODS LIFT |



LEVEL 1

- | | | | | |
|--|--|--|---|---|
|  PLENARY |  KIOSK |  TOILETS |  STAIRS |  PUBLIC LIFT |
|  EXHIBITION SPACE |  BUSINESS SUITE |  LOADING DOCK |  ESCALATOR |  GOODS LIFT |

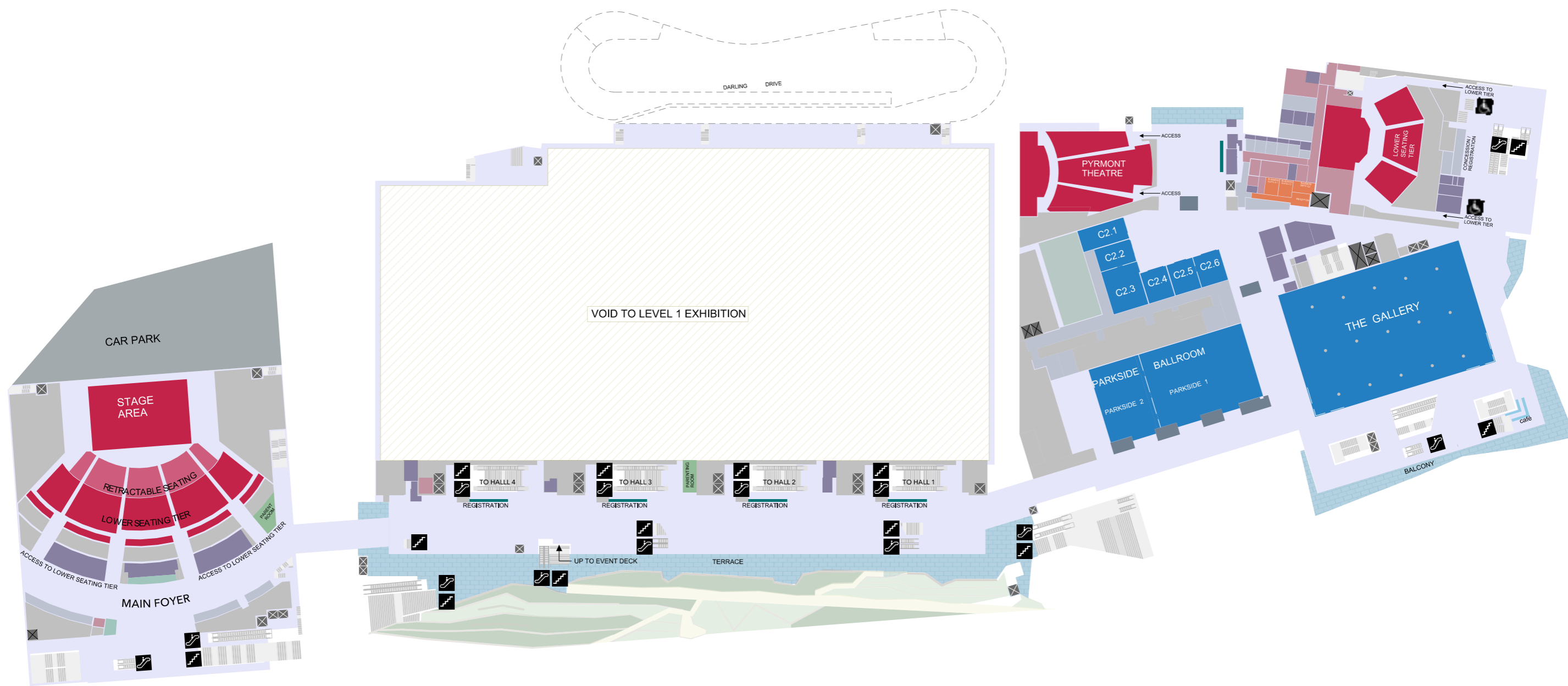





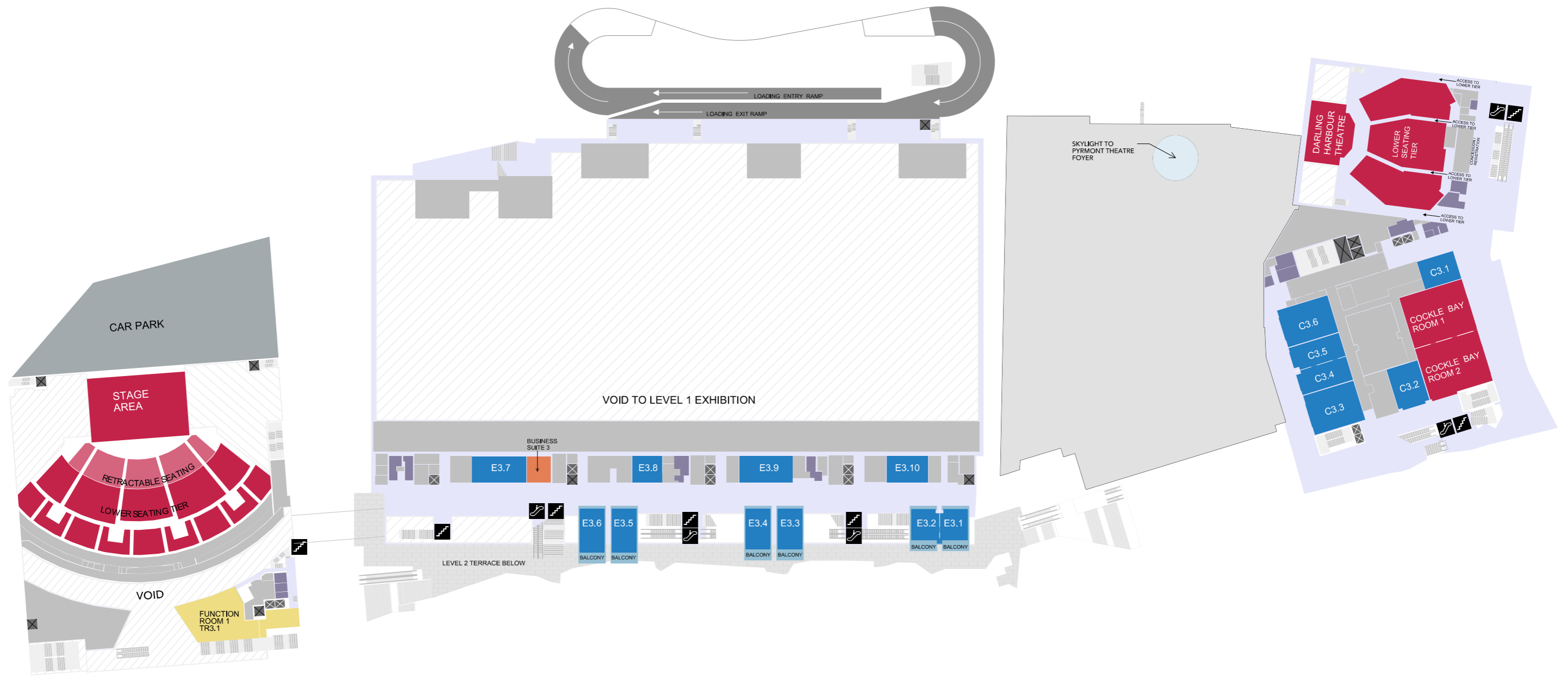

LEVEL 2

- | | | | | | |
|---|--|---|--|---|---|
|  PLENARY |  CIRCULATION |  KIOSK |  BUSINESS SUITE 2 |  STAIRS |  PUBLIC LIFT |
|  MEETING |  REGISTRATION |  TOILETS |  BALCONY |  ESCALATOR |  GOODS LIFT |







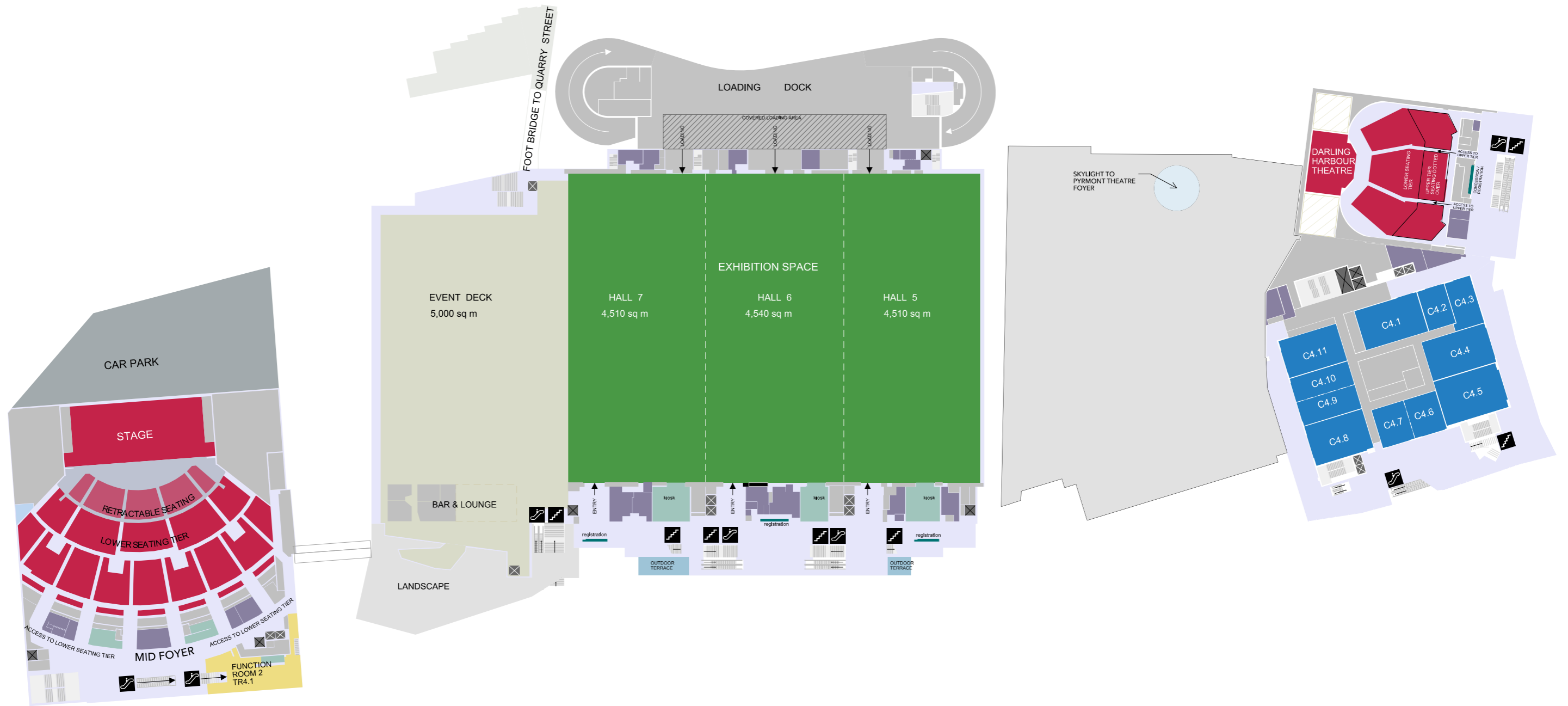







LEVEL 3

- | | | | | | |
|---|--|---|---|---|---|
|  PLENARY |  FUNCTION AREA |  CIRCULATION |  TOILETS |  STAIRS |  PUBLIC LIFT |
|  MEETING |  BUSINESS SUITE |  BALCONY | |  ESCALATOR |  GOODS LIFT |



LEVEL 4

- | | | | | | |
|---|--|---|--|---|---|
|  PLENARY |  EXHIBITION SPACE |  OPEN AIR EVENT DECK |  REGISTRATION |  STAIRS |  PUBLIC LIFT |
|  MEETING |  FUNCTION AREA |  KIOSK / CONCESSION |  TOILETS |  ESCALATOR |  GOODS LIFT |

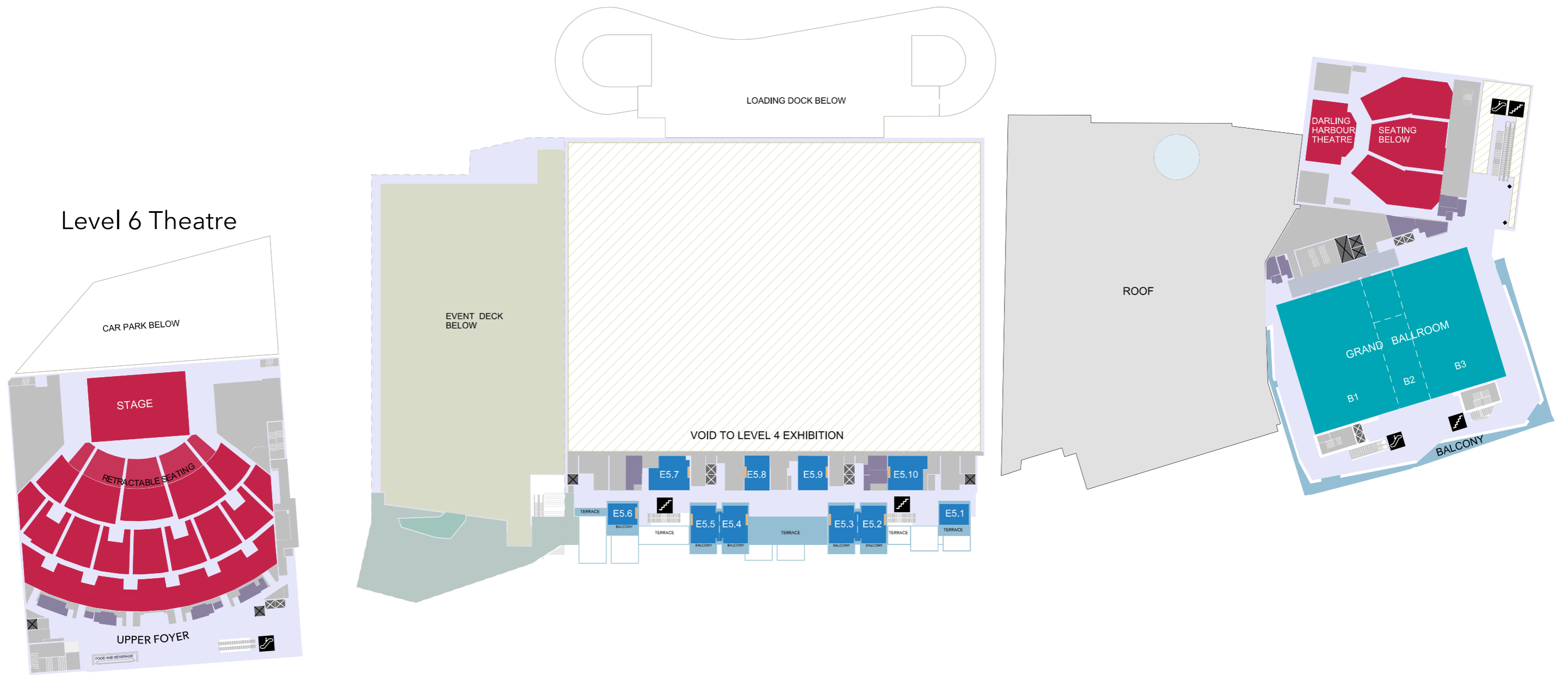

LEVEL 5 Exhibition and Convention. LEVEL 6 Theatre.

- | | | | | |
|---|--|---|---|---|
|  PLENARY |  GRAND BALLROOM |  TOILETS |  STAIRS |  PUBLIC LIFT |
|  MEETING |  CIRCULATION | |  ESCALATOR |  GOODS LIFT |

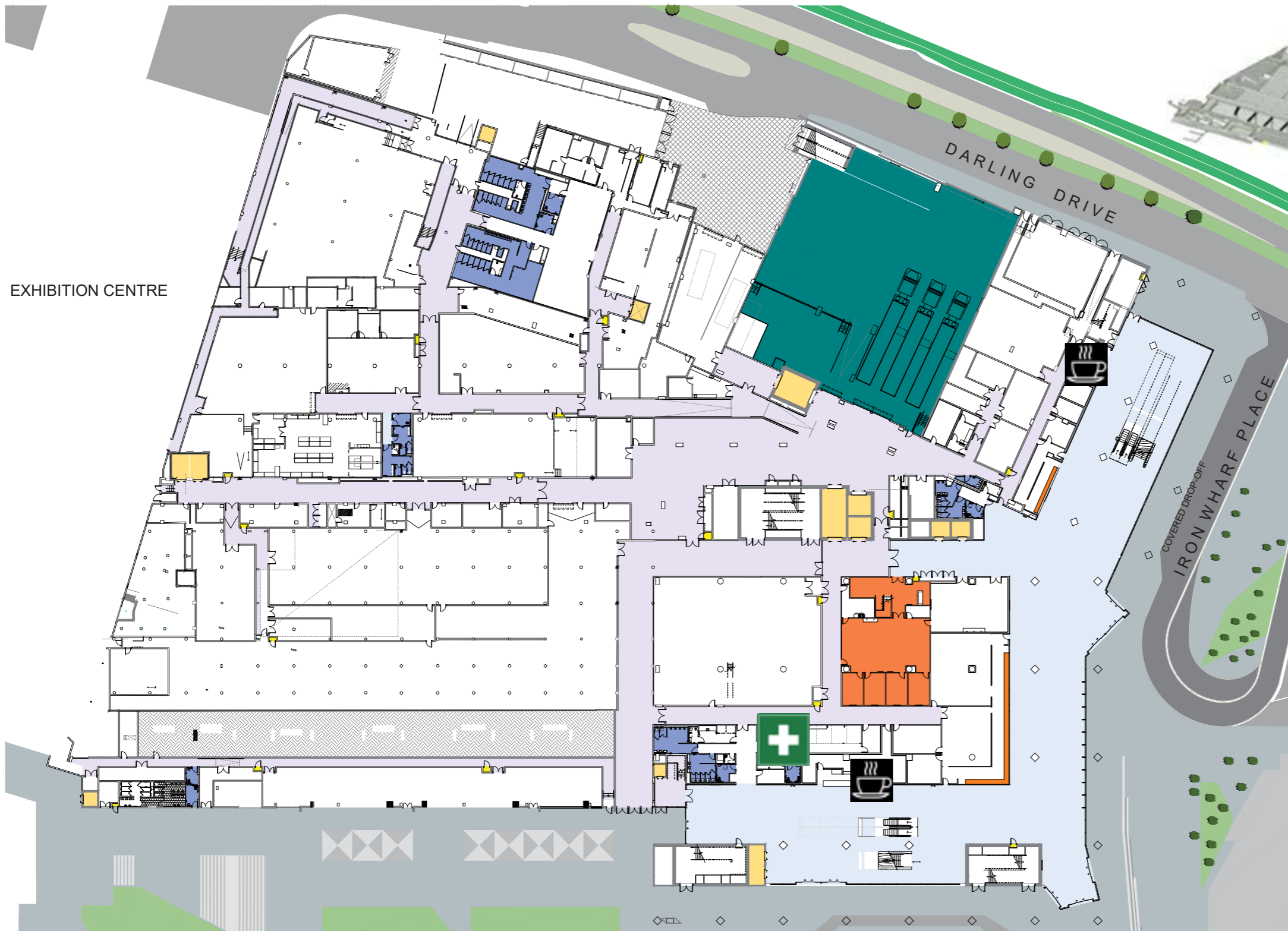

EXHIBITION CENTRE

DARLING DRIVE

COVERED DROP-OFF
IRON WHARF PLACE

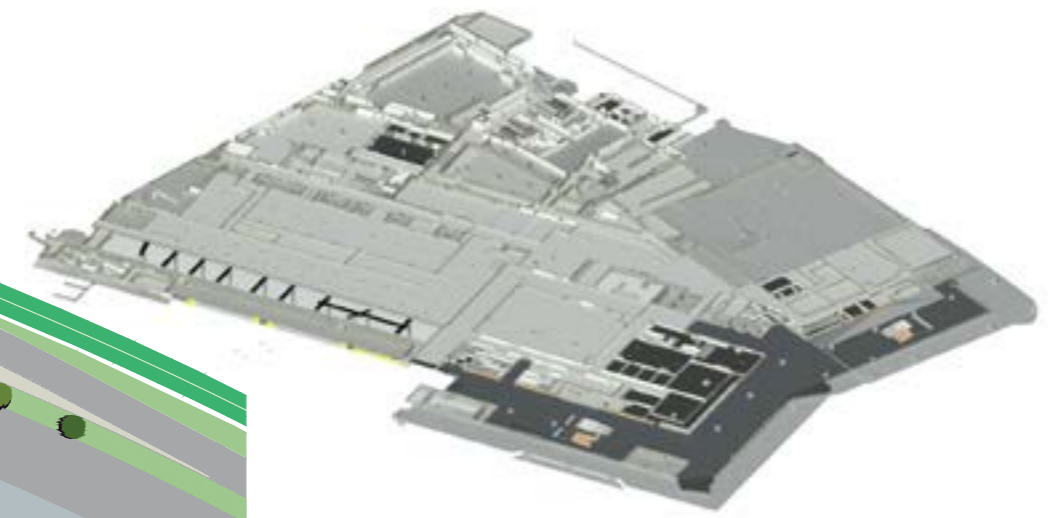

Axonometric cutaway view of Convention Centre Ground Level

LEGEND

- Back of House
- Circulation Back of House
- Circulation Front of House
- Lifts
- Fire Hydrants
- Toilets / Facilities
- Accessible Toilet
- Speaker Preparation Room
- Registration
- Medical Centre
- Cafe
- Loading Dock

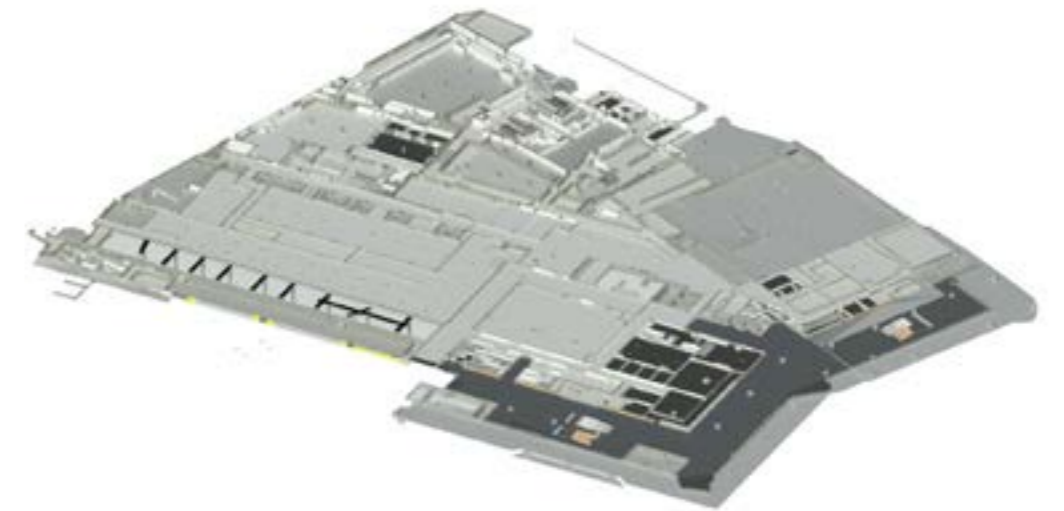
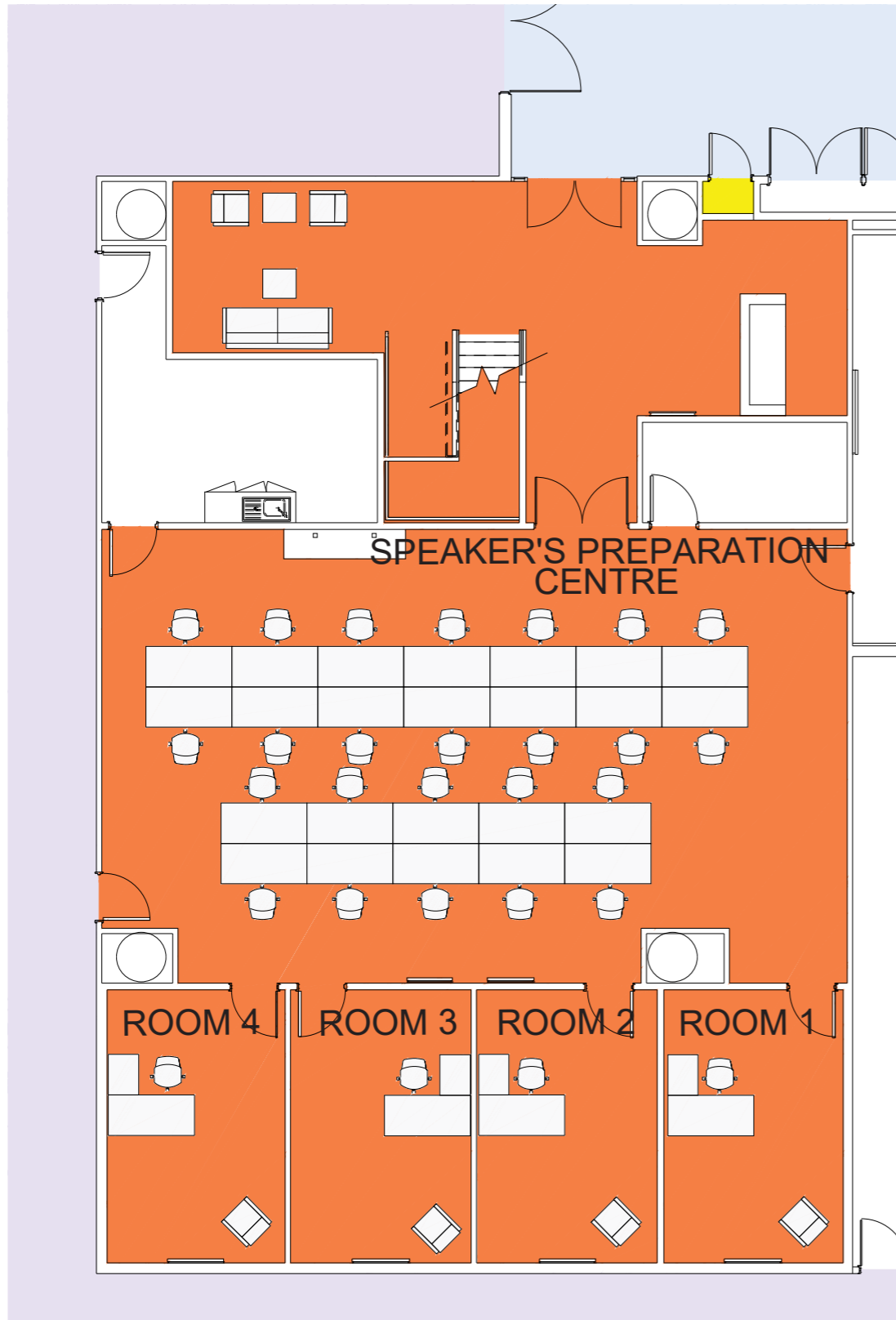

Axonometric cutaway view of Convention Centre Ground Level

LEGEND

- Circulation back of house
- Circulation front of house
- Lifts
- Fire hydrant
- Toilets / facilities
- Speaker's Preparation Centre

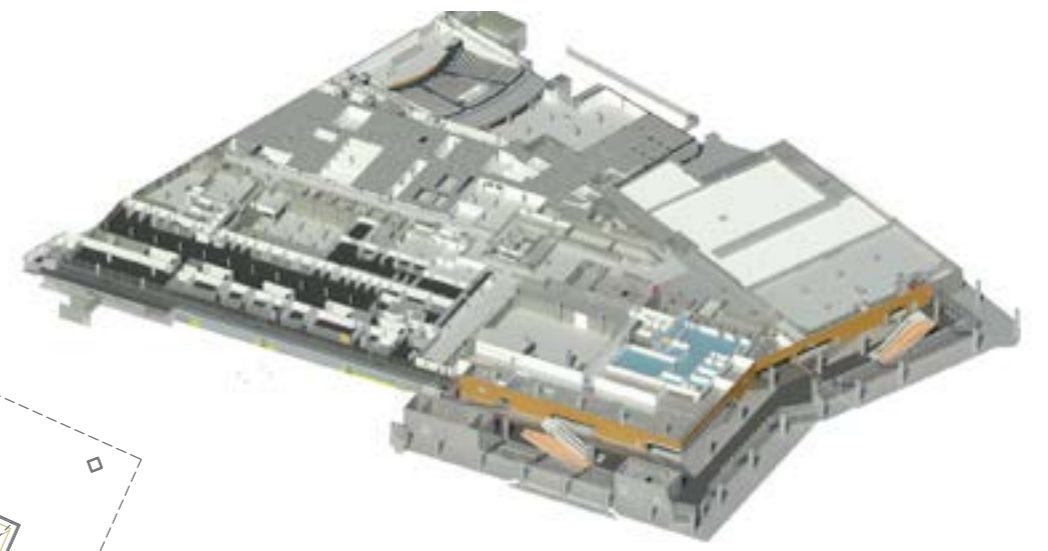

Axonometric cutaway view of Level 1 Convention Centre

- LEGEND**
- Back of House
 - Circulation Back of House
 - Circulation Front of House
 - Lifts
 - Fire Hydrants
 - Toilets / Facilities
 - Accessible Toilet
 - Business Suite 1

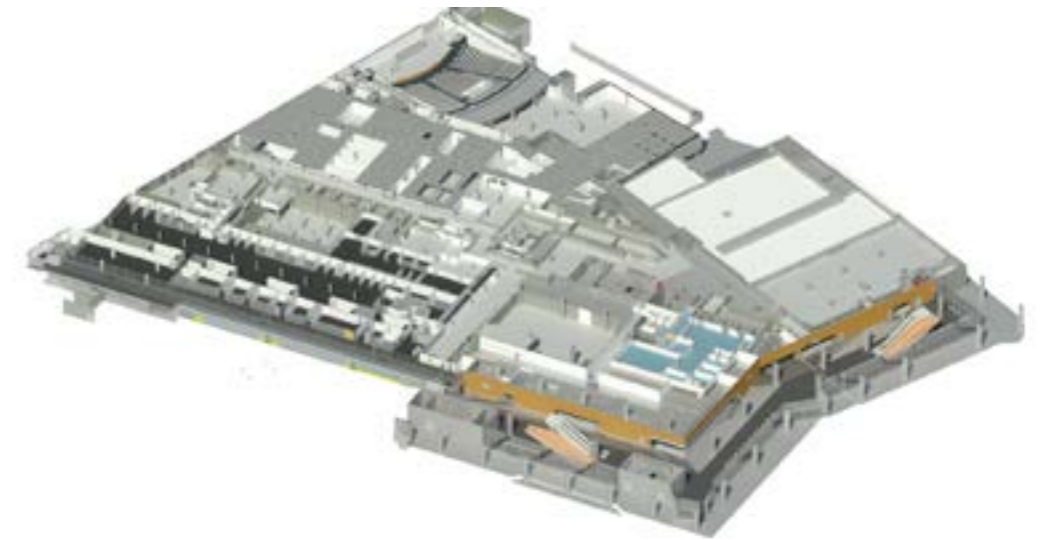
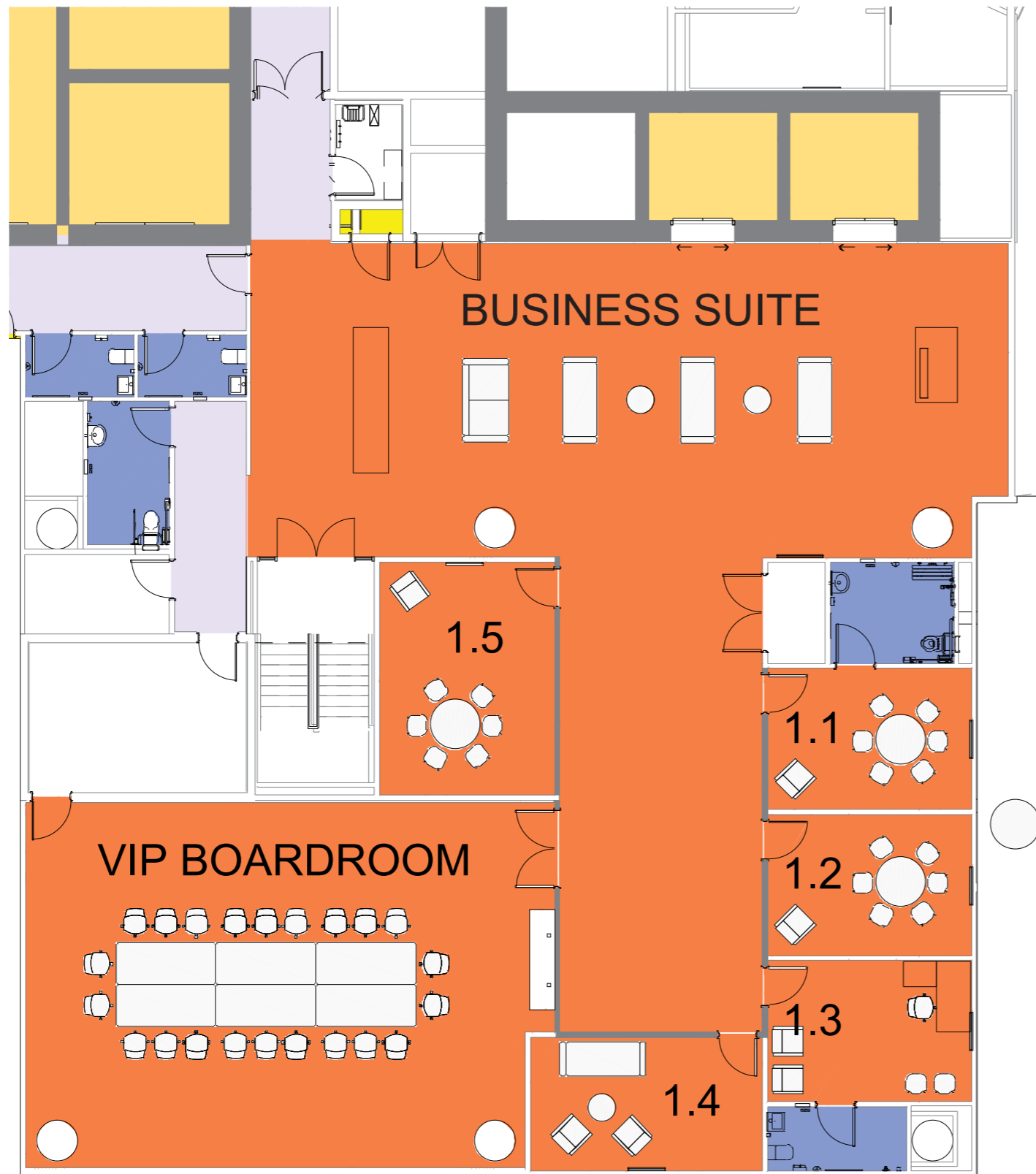

Axonometric cutaway view of Level 1 Convention Centre

LEGEND

- Circulation back of house
- Circulation front of house
- Lifts
- Fire hydrant
- Toilets / facilities
- Business Suite 1

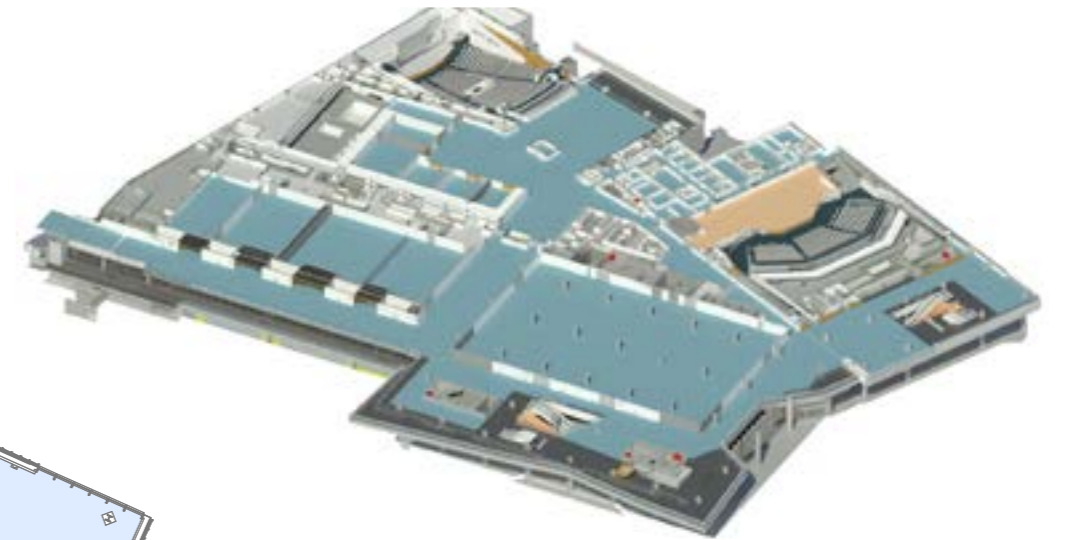

Axonometric cutaway view of Level 2 Convention Centre

LEGEND

- Back of House
- Circulation Back of House
- Circulation Front of House
- Lifts
- Fire Hydrants
- Toilets / Facilities
- Accessible Toilet
- Business Suite 2
- Meeting Rooms, Parkside Ballroom and Gallery

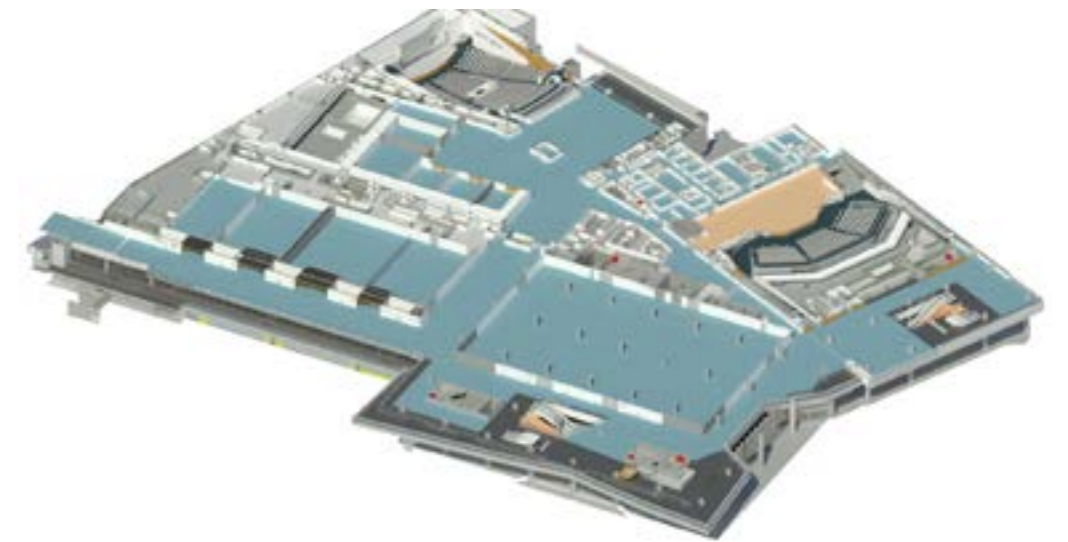
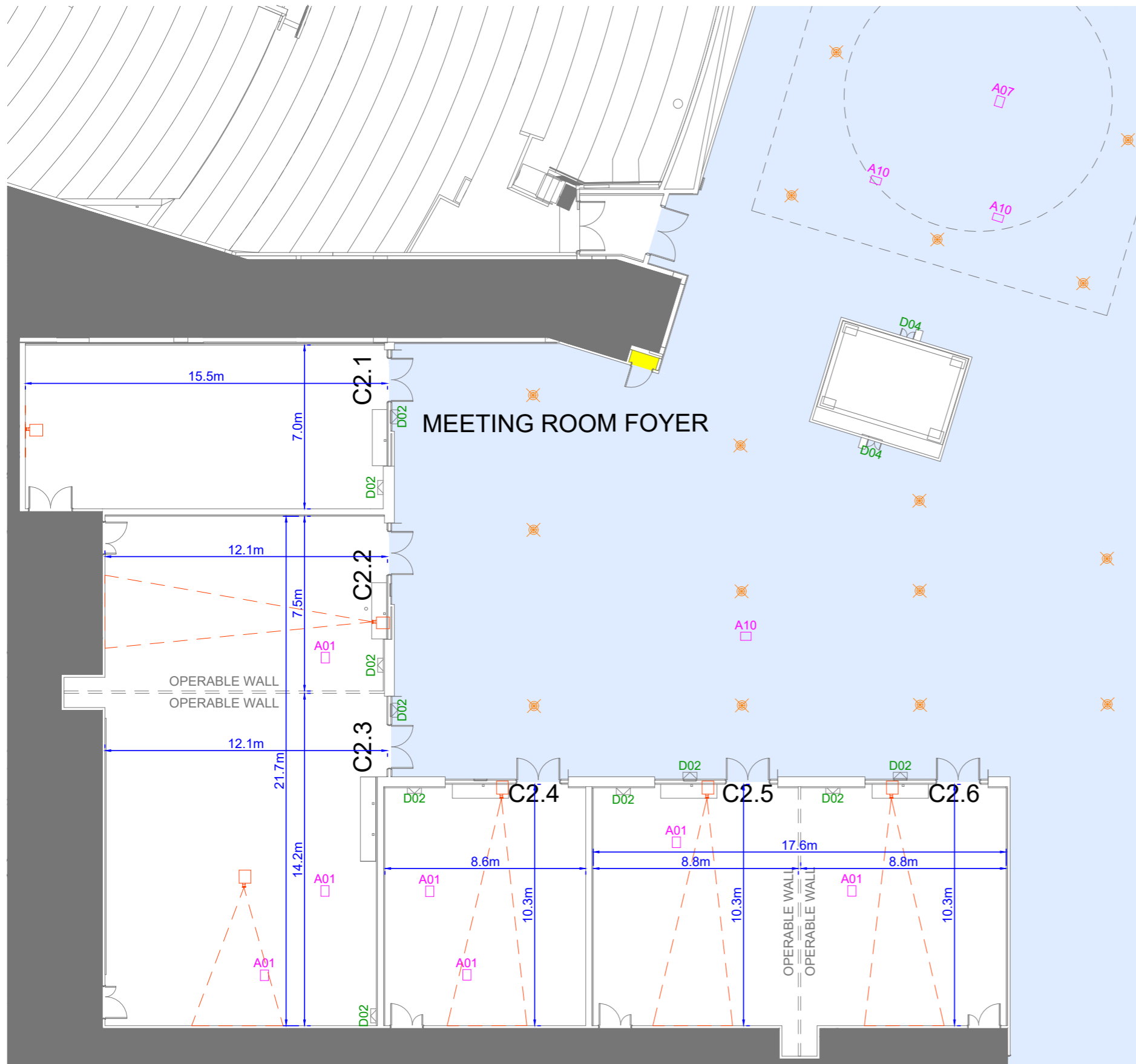

Axonometric cutaway view of Level 2 Convention Centre

LEGEND

- Back of House
- Circulation Back of House
- Circulation Front of House
- Lifts
- Fire Hydrants
- Toilets / Facilities
- Accessible Toilet
- Public Space Build Zone Variable
- A01 Floor Box Type A01
6 x SGPO
2 x SINGLE DATA
2 x SINGLE DATA SUPPLIED AND
INSTALLED BY AV CONTRACTOR
- A04 Floor Box Type A04
3 x SGPO
2 x SINGLE DATA
- A06 Floor Box Type A06
2 x SGPO
1 x 32A 3PH
2 x SINGLE DATA
- A07 Floor Box Type A07
2 x 15A SGPO
1 x 32A 3PH
2 x SINGLE DATA
- A10 Floor Box Type A10
2 x SGPO
1 x 32A 3PH
2 x SINGLE DATA
- D01 Service Cupboard 01
2 x DGPO
1 x 32A 3PH
4 x SINGLE DATA
1 x 6C SMOF
WATER / WASTE
(BY HYDRAULIC CONTRACTOR)
- D02 Service Cupboard 02
2 x DGPO
1 x 32A 3PH
4 x SINGLE DATA
1 x 6C SMOF
- Rigging Point 0.25T
- Projector

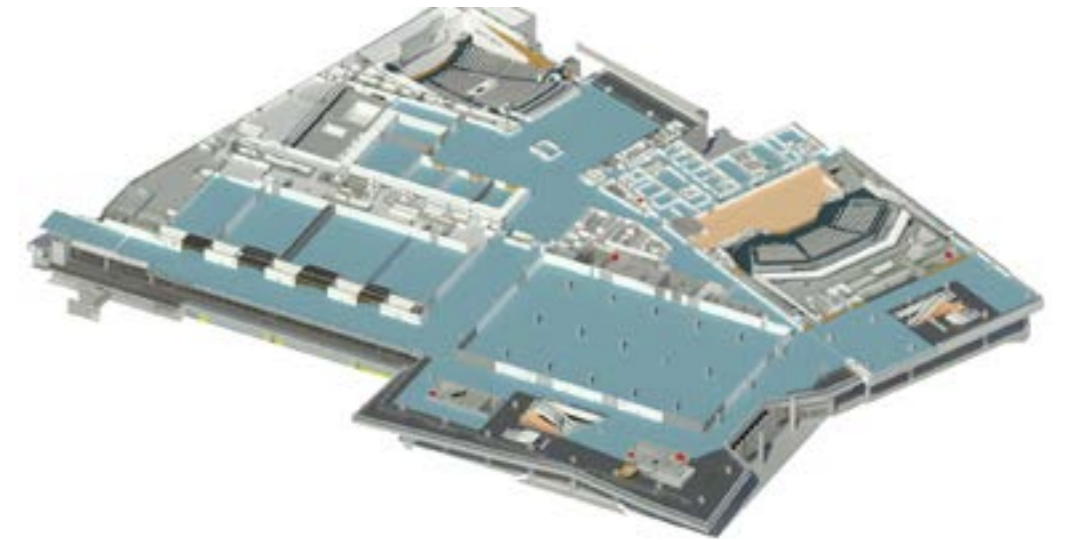
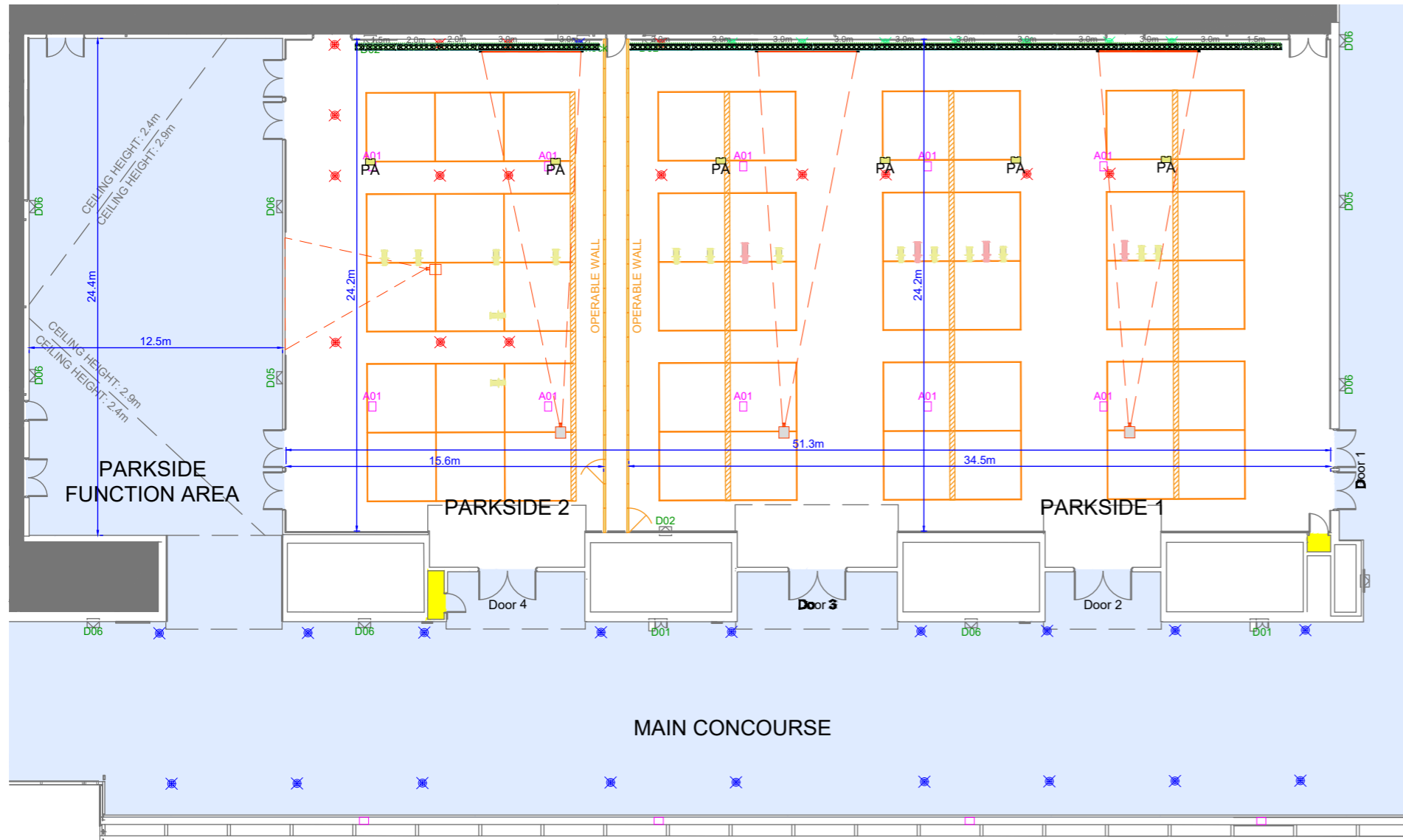

Axonometric cutaway view of Level 2 Convention Centre

LEGEND

- Back of House
- Circulation Back of House
- Circulation Front of House
- Lifts
- Fire Hydrants
- Toilets / Facilities
- Accessible Toilet
- A01 Floor Box Type A01
6 x SGPO
2 x SINGLE DATA
2 x SINGLE DATA SUPPLIED AND INSTALLED BY AV CONTRACTOR
- D01 Service Cupboard 01
2 x DGPO
1 x 32A 3PH
4 x SINGLE DATA
1 x 6C SMOF
WATER / WASTE (BY HIDRAULIC CONTRACTOR)
- D02 Service Cupboard 02
2 x DGPO
1 x 32A 3PH
4 x SINGLE DATA
1 x 6C SMOF
- D05 Service Cupboard 05
1 x DGPO
1 x 32A 3PH
2 x SINGLE DATA
- D06 Service Cupboard 06
1 x DGPO
1 x 20A SGPO
2 x SINGLE DATA
- Rigging Point 1.0T
- Rigging Point 0.5T
- Rigging Point 0.15T
- Rigging Bar 100kg/lm
- Projector
- Public Space Build Zone

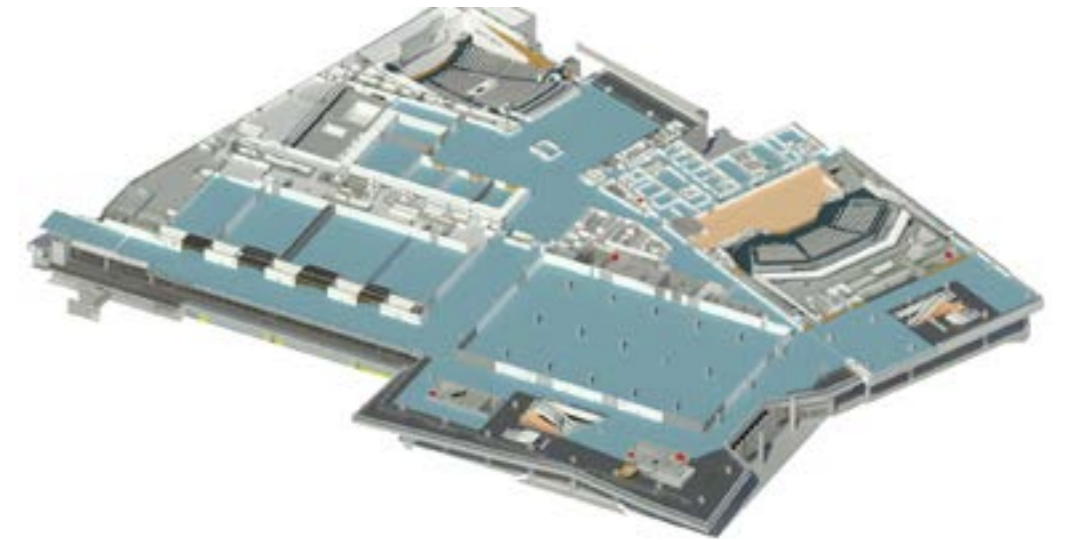
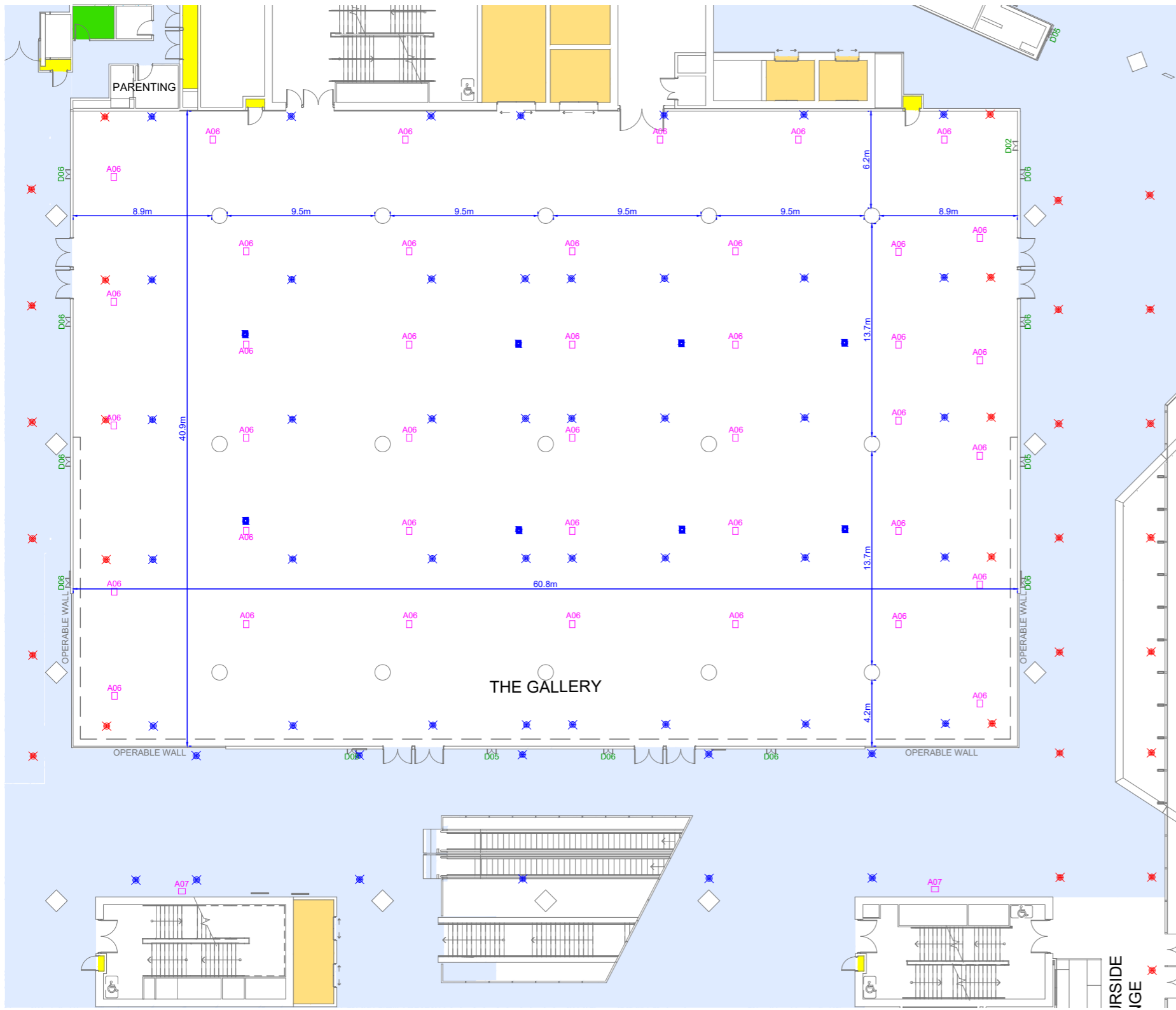

Axonometric cutaway view of Level 2 Convention Centre

LEGEND

- Back of House
 - Circulation Back of House
 - Circulation Front of House
 - Lifts
 - Fire Hydrants
 - Toilets / Facilities
 - Accessible Toilet
-
- A06 Floor Box Type A06
2 x SGPO
1 x 32A 3PH
2 x SINGLE DATA
 - D02 Service Cupboard 02
2 x DGPO
1 x 32A 3PH
4 x SINGLE DATA
1 x 6C SMOF
 - D05 Service Cupboard 05
1 x DGPO
1 x 32A 3PH
2 x SINGLE DATA
 - D06 Service Cupboard 06
1 x DGPO
1 x 20A SGPO
2 x SINGLE DATA
 - Wet Pit
1 x Ø 20mm Water Outlet
1 x 75mm Ø Drain
 - Rigging Point 1.0T
 - Rigging Point 0.5T
 - Public Space Build Zone

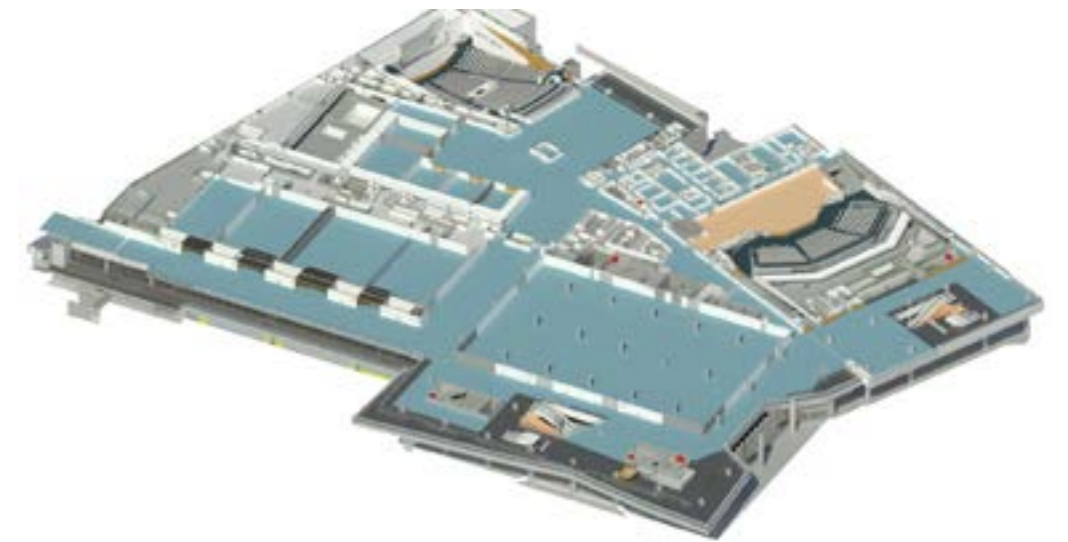
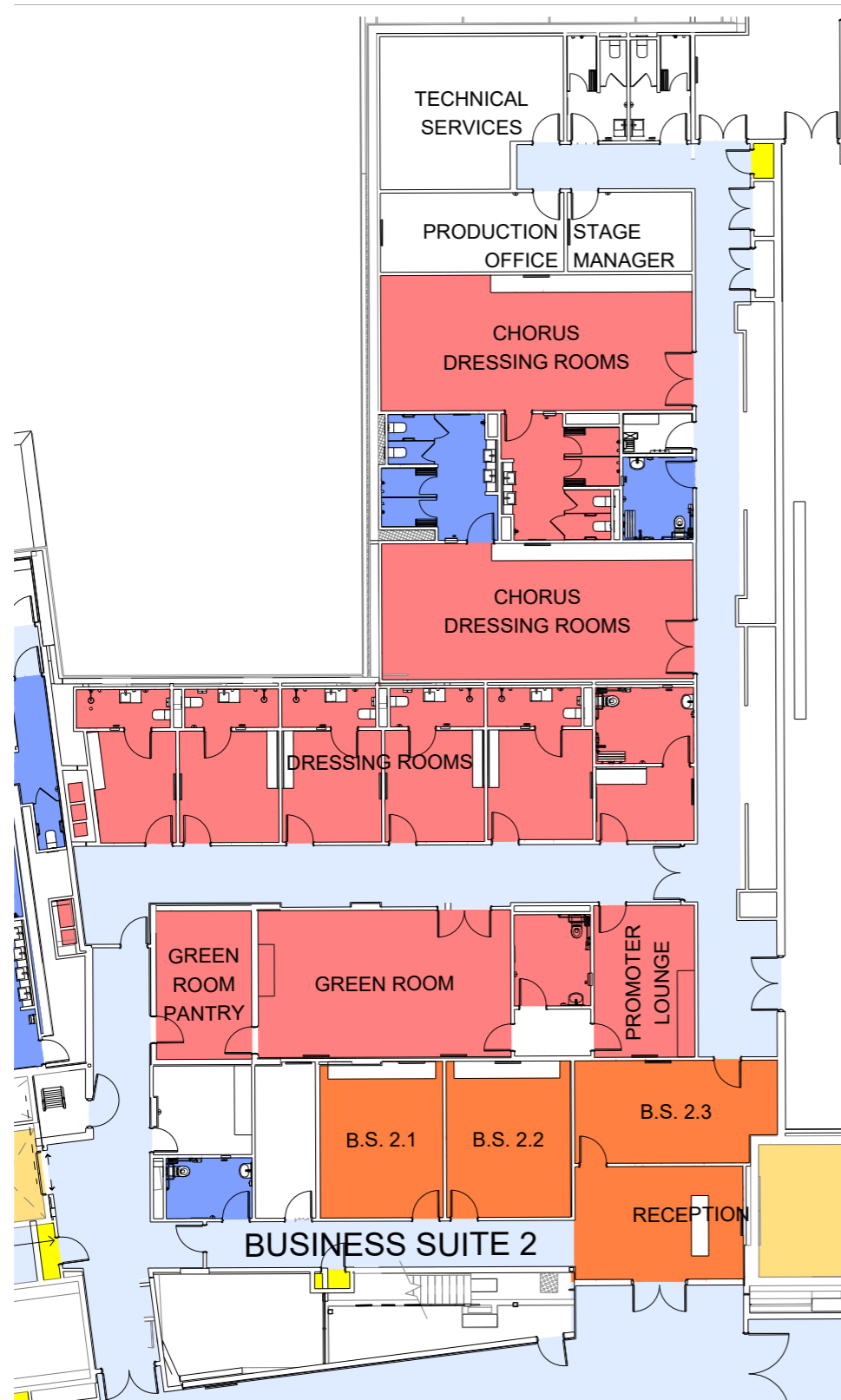

Axonometric cutaway view of Level 2 Convention Centre

LEGEND

- Circulation back of house
- Circulation front of house
- Lifts
- Fire hydrant
- Toilets / facilities
- Business Suite 2
- Meeting Rooms, Parkside Ballroom and Gallery
- Darling Harbour Theatre Facilities

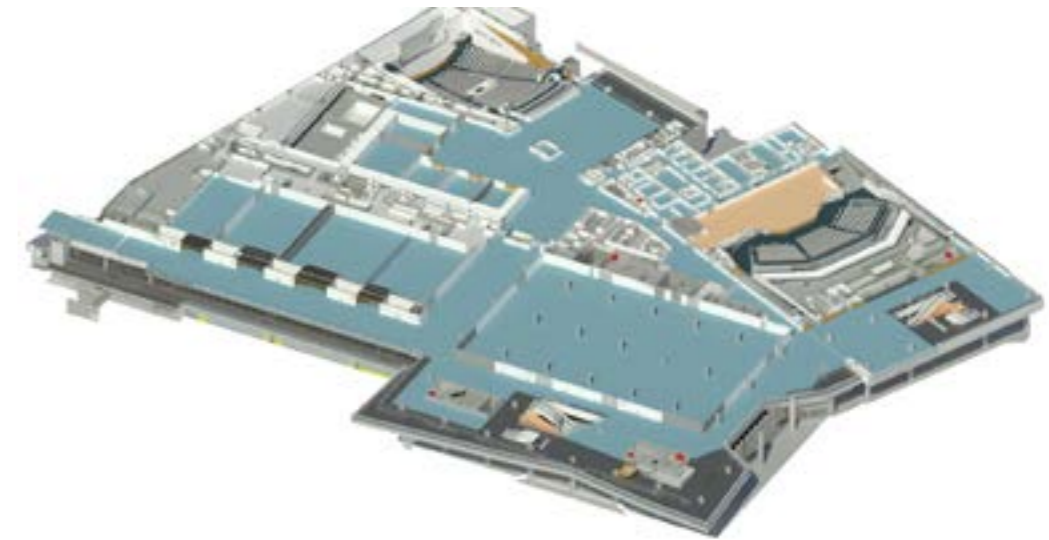

Axonometric cutaway view of Level 2 Convention Centre

ROOM NAME	BANQUET
MEETING ROOM C2.1	60
MEETING ROOM C2.2	40
MEETING ROOM C2.3	80
MEETING ROOM C2.2 & C2.3	140
MEETING ROOM C2.4	30
MEETING ROOM C2.5	30
MEETING ROOM C2.6	30
MEETING ROOM C2.5 & C2.6	90
PARKSIDE BALLROOM	700
PARKSIDE BALLROOM 1	460
PARKSIDE BALLROOM 2	200

LEGEND

- Circulation back of house
- Circulation front of house
- Lifts
- Fire hydrant
- Toilets / facilities
- Business Suite 2
- Meeting Rooms, Parkside Ballroom and Gallery
- Darling Harbour Theatre Facilities

* Standard capacity illustrated. Higher capacities can be achieved with less staging and AV services and reduced furniture spacing. Please consider your event requirements when viewing capacities.

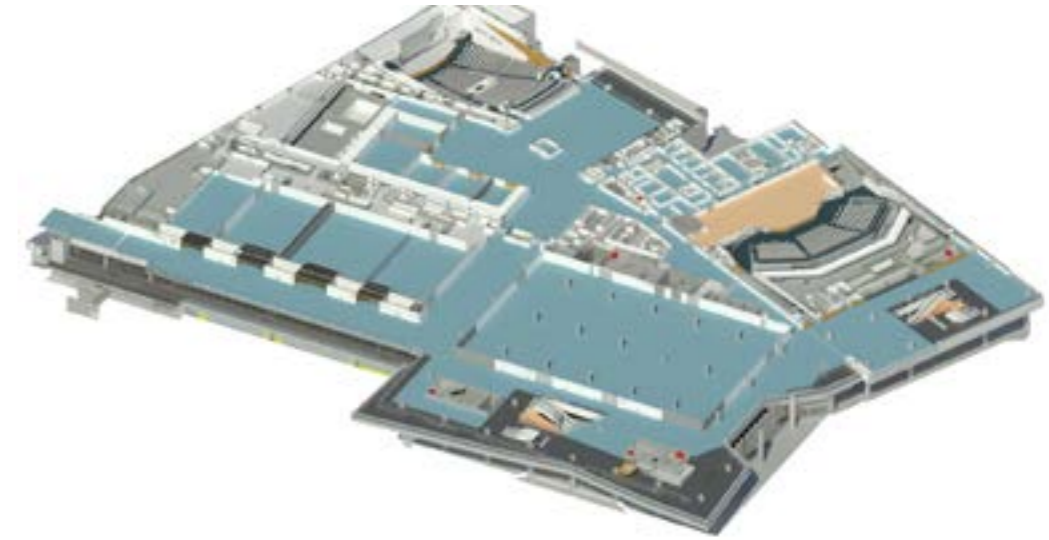

Axonometric cutaway view of Level 2 Convention Centre

ROOM NAME	BANQUET
MEETING ROOM C2.1	60
MEETING ROOM C2.2	40
MEETING ROOM C2.3	80
MEETING ROOM C2.2 & C2.3	140
MEETING ROOM C2.4	30
MEETING ROOM C2.5	30
MEETING ROOM C2.6	30
MEETING ROOM C2.5 & C2.6	90
PARKSIDE BALLROOM	700
PARKSIDE BALLROOM 1	460
PARKSIDE BALLROOM 2	200

LEGEND

- Circulation back of house
- Circulation front of house
- Lifts
- Fire hydrant
- Toilets / facilities
- Business Suite 2
- Meeting Rooms, Parkside Ballroom and Gallery
- Darling Harbour Theatre Facilities

* Standard capacity illustrated. Higher capacities can be achieved with less staging and AV services and reduced furniture spacing. Please consider your event requirements when viewing capacities.

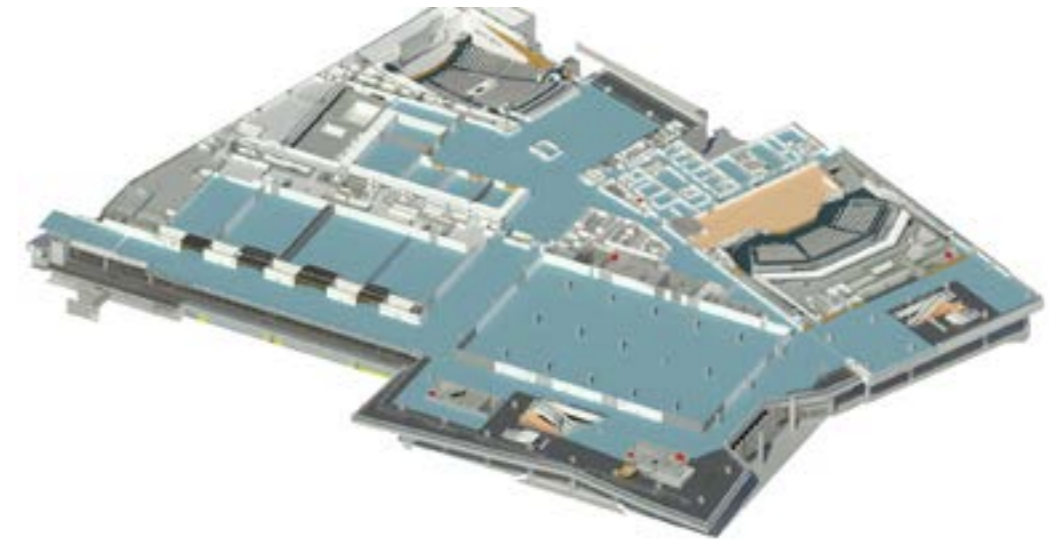
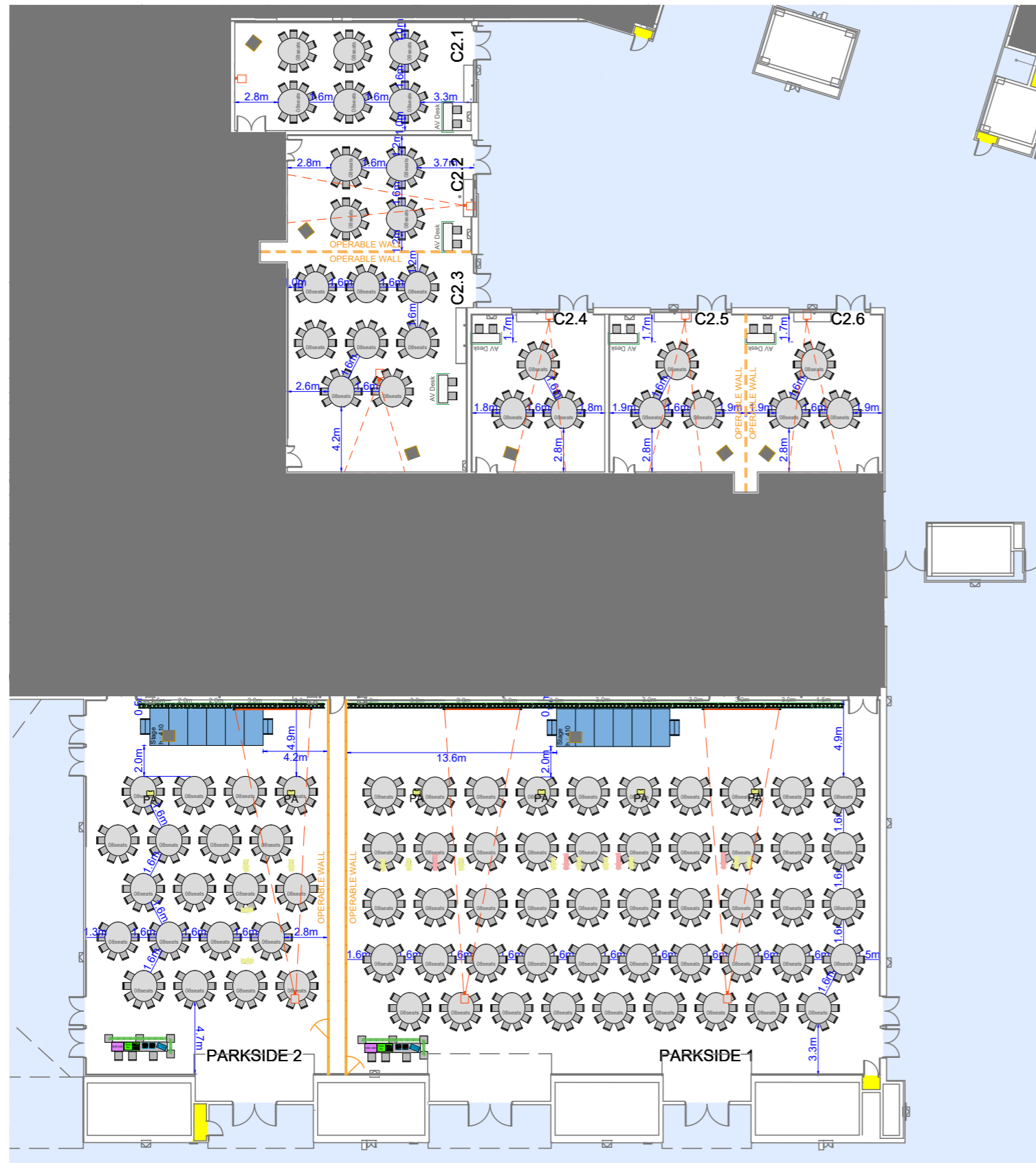

Axonometric cutaway view of Level 2 Convention Centre

ROOM NAME	CABARET
MEETING ROOM C2.1	48
MEETING ROOM C2.2	32
MEETING ROOM C2.3	64
MEETING ROOM C2.2 & C2.3	112
MEETING ROOM C2.4	24
MEETING ROOM C2.5	24
MEETING ROOM C2.6	24
MEETING ROOM C2.5 & C2.6	72
PARKSIDE BALLROOM	576
PARKSIDE BALLROOM 1	392
PARKSIDE BALLROOM 2	160

LEGEND

- Circulation back of house
- Circulation front of house
- Lifts
- Fire hydrant
- Toilets / facilities
- Business Suite 2
- Meeting Rooms, Parkside Ballroom and Gallery
- Darling Harbour Theatre Facilities

* Standard capacity illustrated. Higher capacities can be achieved with less staging and AV services and reduced furniture spacing. Please consider your event requirements when viewing capacities.

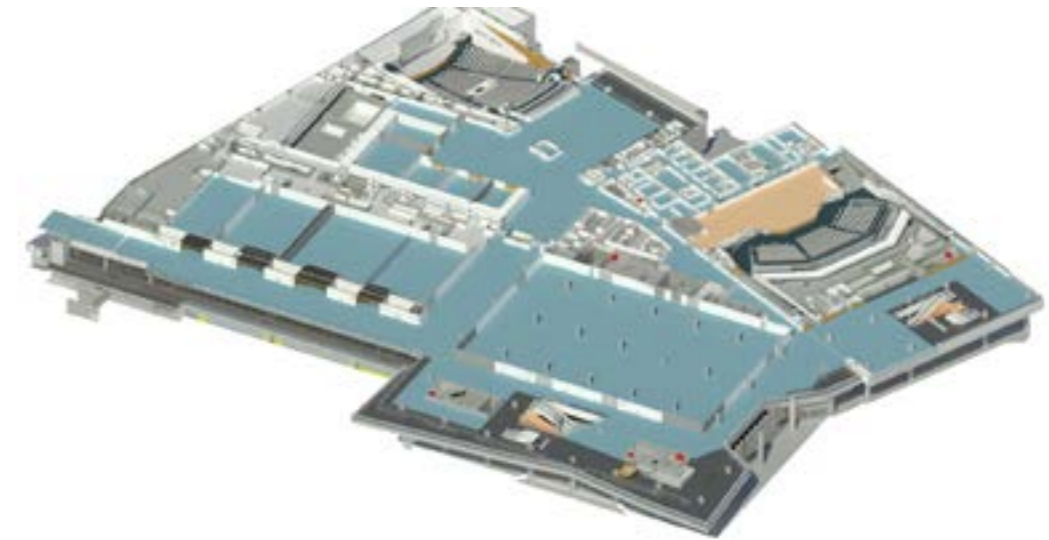

Axonometric cutaway view of Level 2 Convention Centre

ROOM NAME	CABARET
MEETING ROOM C2.1	48
MEETING ROOM C2.2	32
MEETING ROOM C2.3	64
MEETING ROOM C2.2 & C2.3	112
MEETING ROOM C2.4	24
MEETING ROOM C2.5	24
MEETING ROOM C2.6	24
MEETING ROOM C2.5 & C2.6	72
PARKSIDE BALLROOM	576
PARKSIDE BALLROOM 1	392
PARKSIDE BALLROOM 2	160

LEGEND

- Circulation back of house
- Circulation front of house
- Lifts
- Fire hydrant
- Toilets / facilities
- Business Suite 2
- Meeting Rooms, Parkside Ballroom and Gallery
- Darling Harbour Theatre Facilities

* Standard capacity illustrated. Higher capacities can be achieved with less staging and AV services and reduced furniture spacing. Please consider your event requirements when viewing capacities.

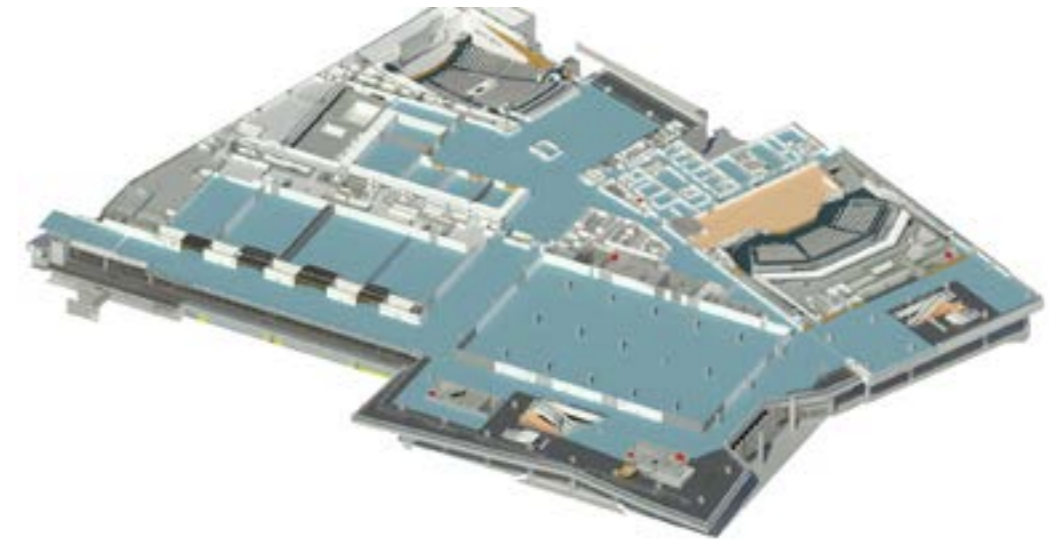
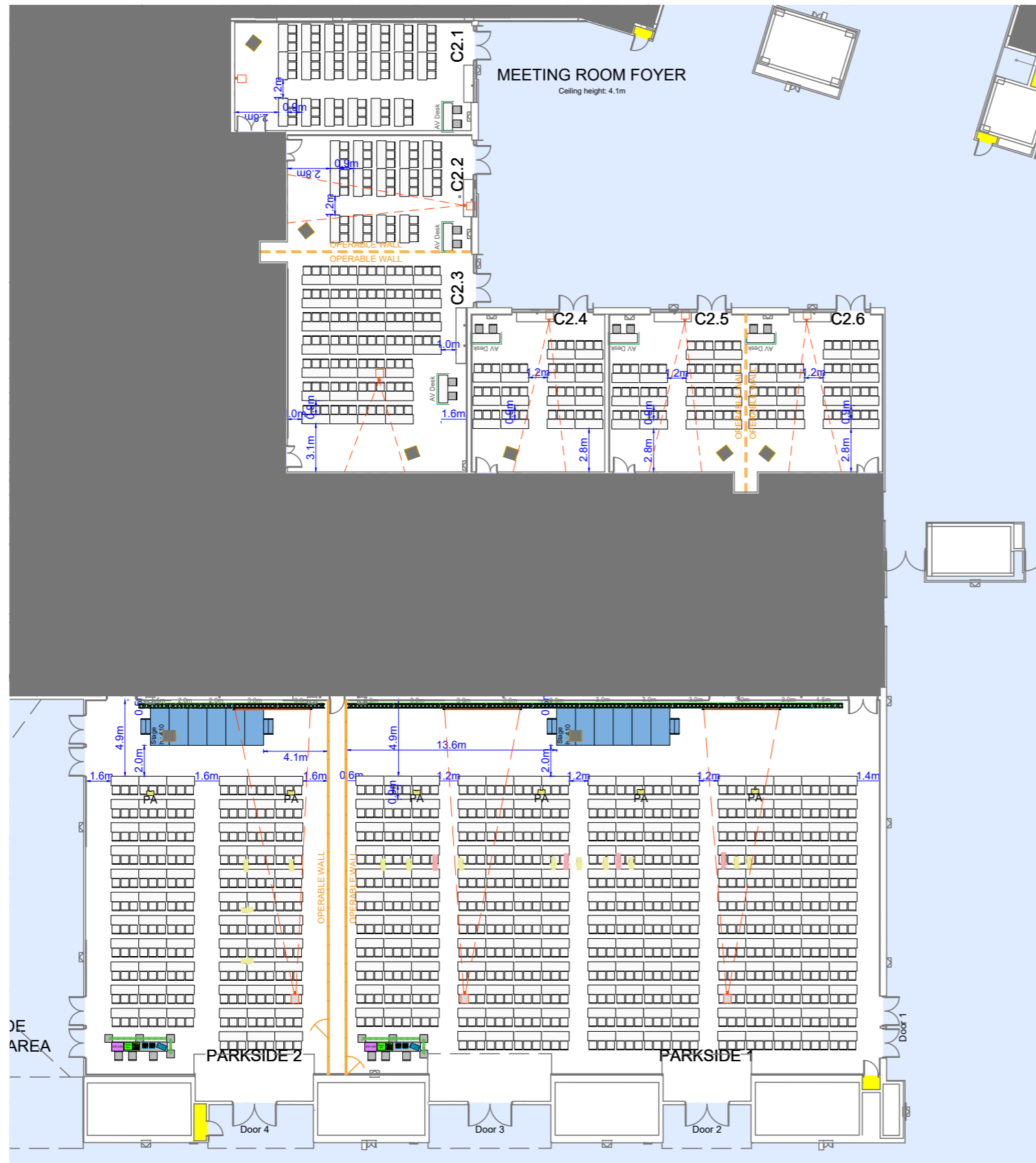

Axonometric cutaway view of Level 2 Convention Centre

ROOM NAME	CLASSROOM
MEETING ROOM C2.1	60
MEETING ROOM C2.2	42
MEETING ROOM C2.3	96
MEETING ROOM C2.2 & C2.3	171
MEETING ROOM C2.4	42
MEETING ROOM C2.5	42
MEETING ROOM C2.6	42
MEETING ROOM C2.5 & C2.6	90
PARKSIDE BALLROOM	825
PARKSIDE BALLROOM 1	567
PARKSIDE BALLROOM 2	207

LEGEND

- Circulation back of house
- Circulation front of house
- Lifts
- Fire hydrant
- Toilets / facilities
- Business Suite 2
- Meeting Rooms, Parkside Ballroom and Gallery
- Darling Harbour Theatre Facilities

* Standard capacity illustrated. Higher capacities can be achieved with less staging and AV services and reduced furniture spacing. Please consider your event requirements when viewing capacities

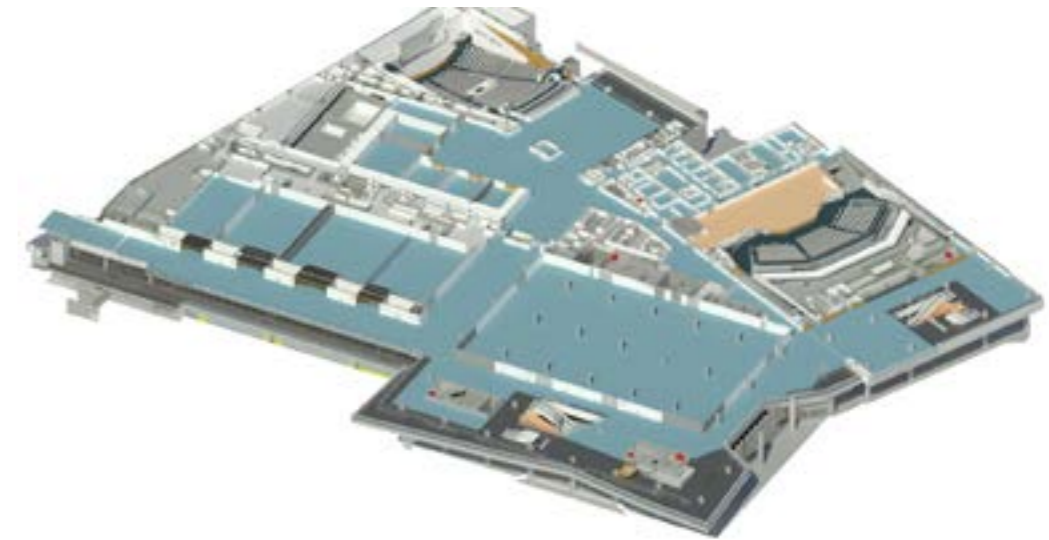
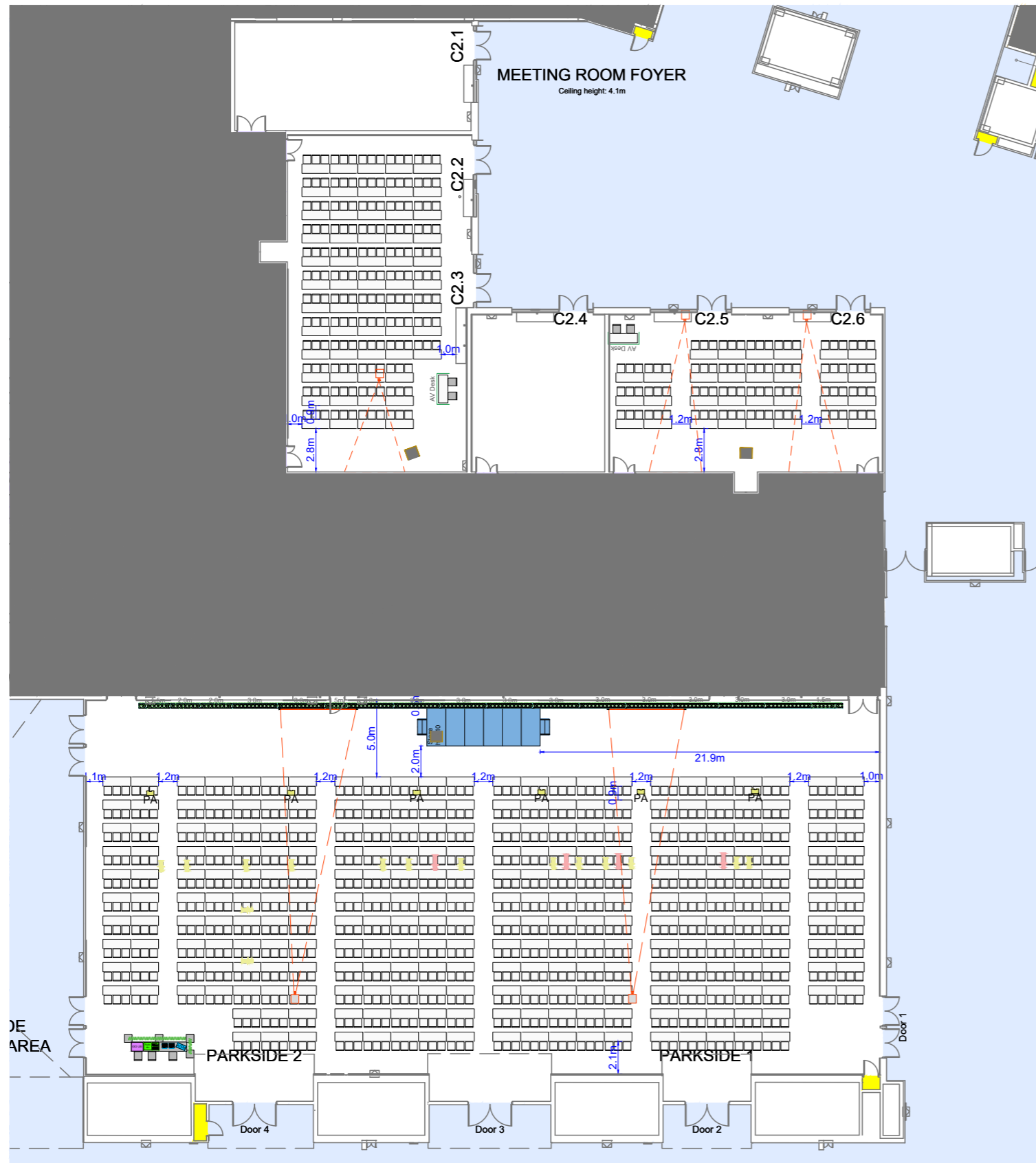

Axonometric cutaway view of Level 2 Convention Centre

ROOM NAME	CLASSROOM
MEETING ROOM C2.1	60
MEETING ROOM C2.2	42
MEETING ROOM C2.3	96
MEETING ROOM C2.2 & C2.3	171
MEETING ROOM C2.4	42
MEETING ROOM C2.5	42
MEETING ROOM C2.6	42
MEETING ROOM C2.5 & C2.6	90
PARKSIDE BALLROOM	825
PARKSIDE BALLROOM 1	567
PARKSIDE BALLROOM 2	207

LEGEND

- Circulation back of house
- Circulation front of house
- Lifts
- Fire hydrant
- Toilets / facilities
- Business Suite 2
- Meeting Rooms, Parkside Ballroom and Gallery
- Darling Harbour Theatre Facilities

* Standard capacity illustrated. Higher capacities can be achieved with less staging and AV services and reduced furniture spacing. Please consider your event requirements when viewing capacities.

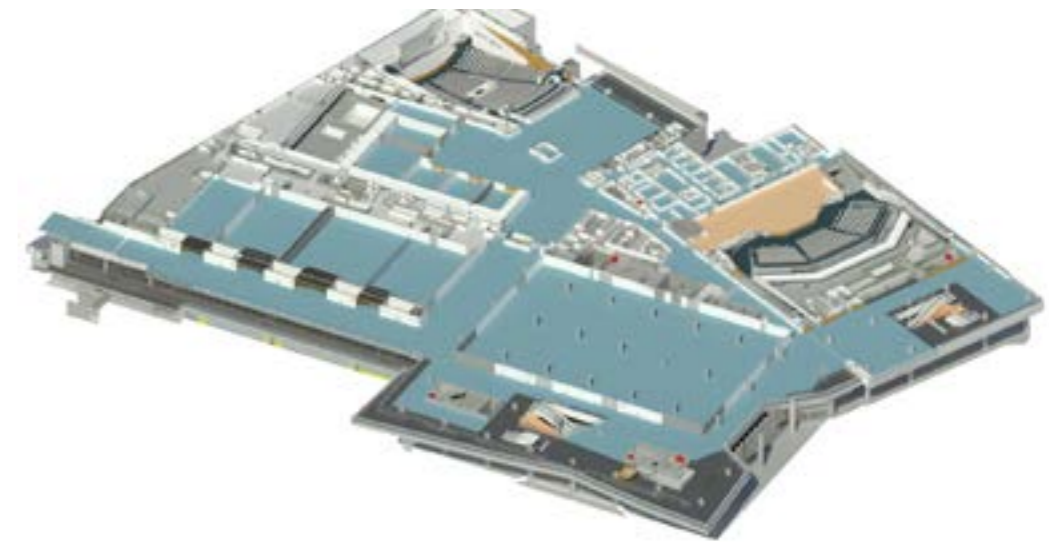

Axonometric cutaway view of Level 2 Convention Centre

ROOM NAME	THEATRE
MEETING ROOM C2.1	105
MEETING ROOM C2.2	78
MEETING ROOM C2.3	149
MEETING ROOM C2.2 & C2.3	245
MEETING ROOM C2.4	77
MEETING ROOM C2.5	77
MEETING ROOM C2.6	77
MEETING ROOM C2.5 & C2.6	165
PARKSIDE BALLROOM	1429
PARKSIDE BALLROOM 1	962
PARKSIDE BALLROOM 2	396

LEGEND

- Circulation back of house
- Circulation front of house
- Lifts
- Fire hydrant
- Toilets / facilities
- Business Suite 2
- Meeting Rooms, Parkside Ballroom and Gallery
- Darling Harbour Theatre Facilities

* Standard capacity illustrated. Higher capacities can be achieved with less staging and AV services and reduced furniture spacing. Please consider your event requirements when viewing capacities.

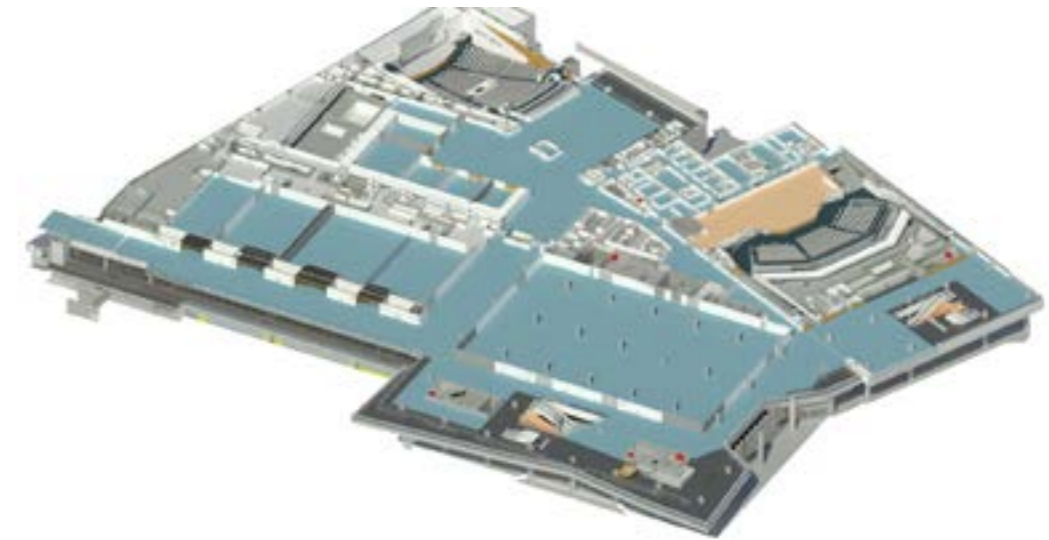

Axonometric cutaway view of Level 2 Convention Centre

ROOM NAME	THEATRE
MEETING ROOM C2.1	105
MEETING ROOM C2.2	78
MEETING ROOM C2.3	143
MEETING ROOM C2.2 & C2.3	245
MEETING ROOM C2.4	77
MEETING ROOM C2.5	77
MEETING ROOM C2.6	77
MEETING ROOM C2.5 & C2.6	165
PARKSIDE BALLROOM	1429
PARKSIDE BALLROOM 1	962
PARKSIDE BALLROOM 2	396

LEGEND

- Circulation back of house
- Circulation front of house
- Lifts
- Fire hydrant
- Toilets / facilities
- Business Suite 2
- Meeting Rooms, Parkside Ballroom and Gallery
- Darling Harbour Theatre Facilities

* Standard capacity illustrated. Higher capacities can be achieved with less staging and AV services and reduced furniture spacing. Please consider your event requirements when viewing capacities.

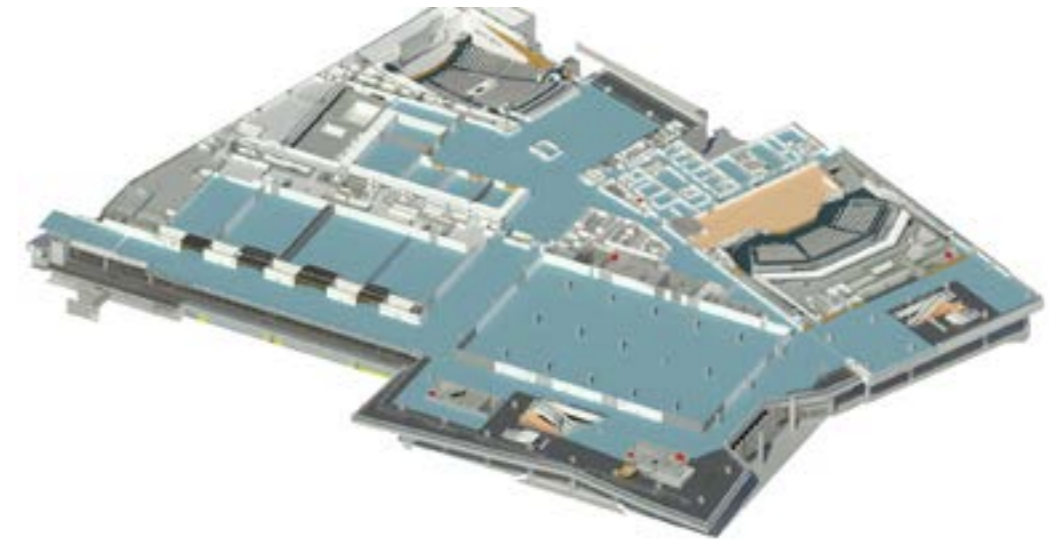
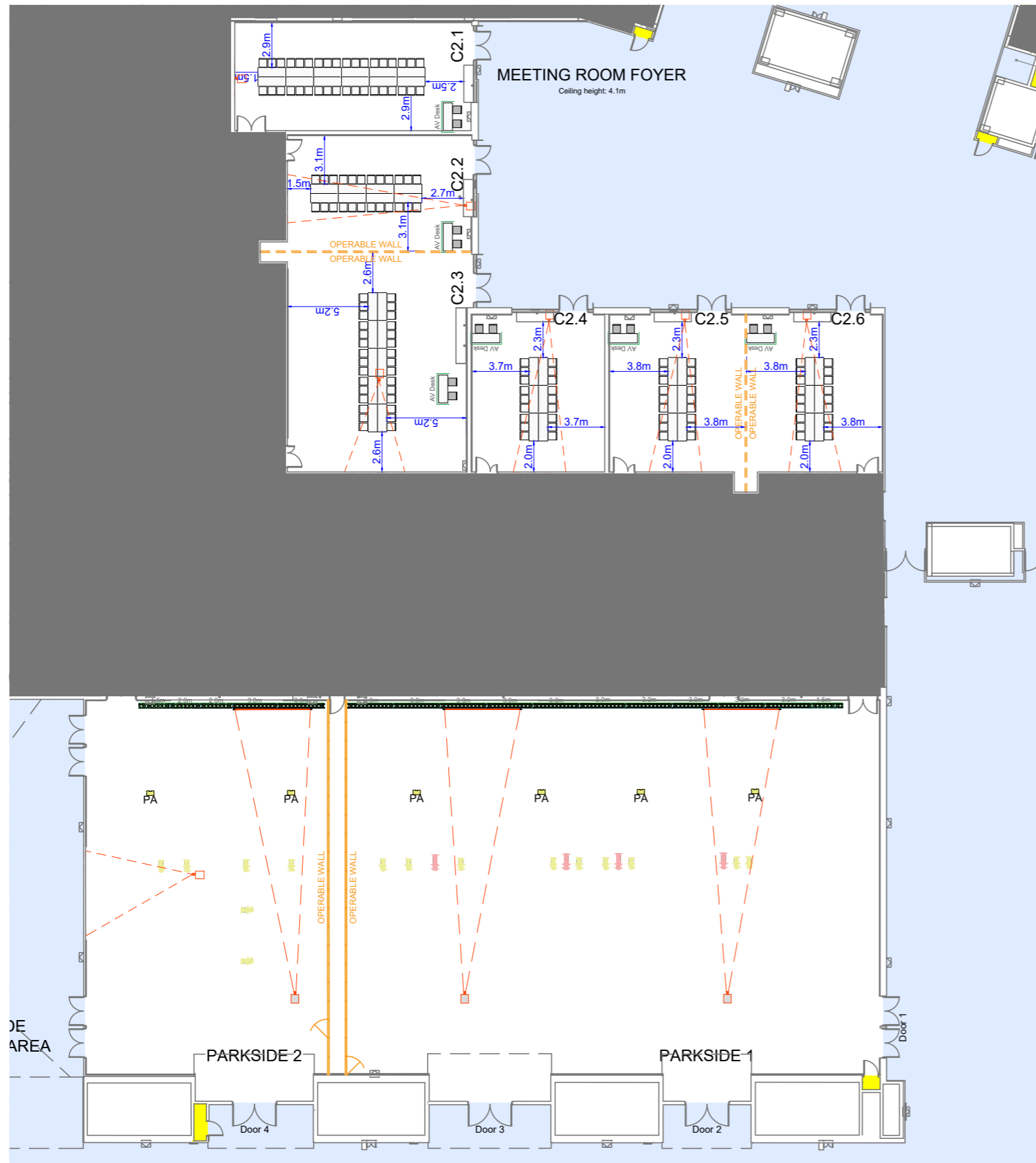

Axonometric cutaway view of Level 2 Convention Centre

ROOM NAME	BOARDROOM
MEETING ROOM C2.1	36
MEETING ROOM C2.2	24
MEETING ROOM C2.3	30
MEETING ROOM C2.2 & C2.3	54
MEETING ROOM C2.4	18
MEETING ROOM C2.5	18
MEETING ROOM C2.6	18
MEETING ROOM C2.5 & C2.6	42

LEGEND

- Circulation back of house
- Circulation front of house
- Lifts
- Fire hydrant
- Toilets / facilities
- Business Suite 2
- Meeting Rooms, Parkside Ballroom and Gallery
- Darling Harbour Theatre Facilities

* Standard capacity illustrated. Higher capacities can be achieved with less staging and AV services and reduced furniture spacing. Please consider your event requirements when viewing capacities.

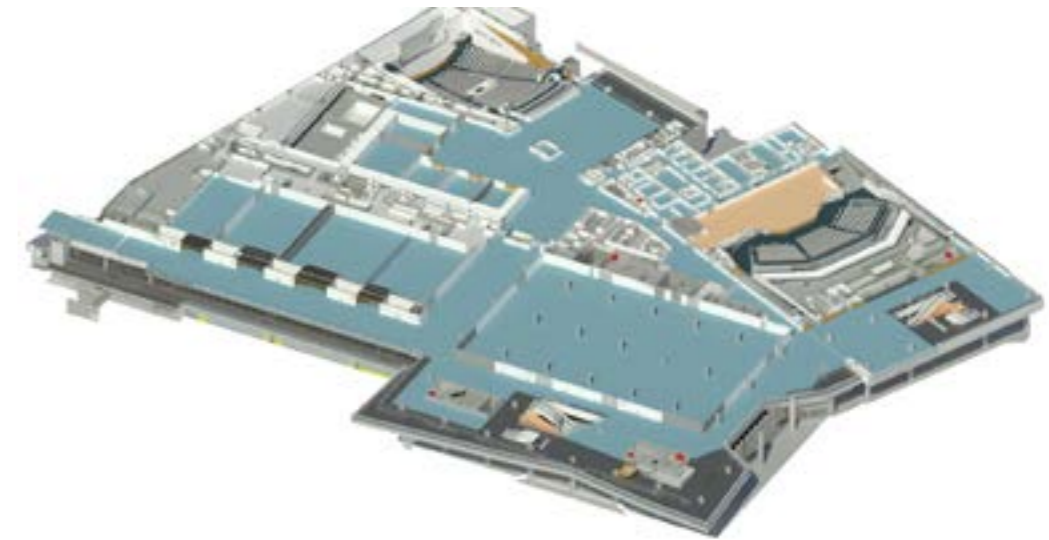
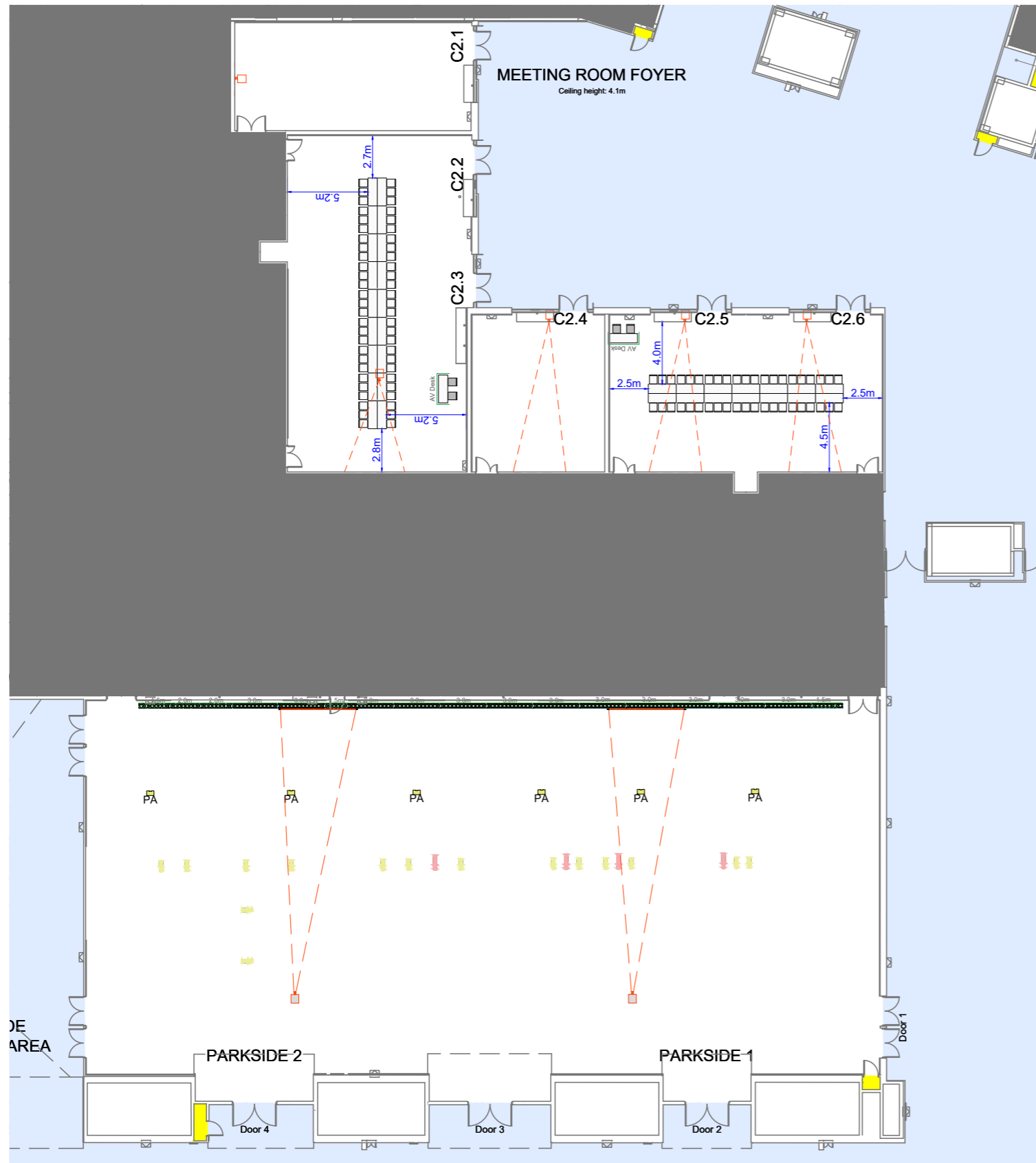

Axonometric cutaway view of Level 2 Convention Centre

ROOM NAME	BOARDROOM
MEETING ROOM C2.1	36
MEETING ROOM C2.2	24
MEETING ROOM C2.3	30
MEETING ROOM C2.2 & C2.3	54
MEETING ROOM C2.4	18
MEETING ROOM C2.5	18
MEETING ROOM C2.6	18
MEETING ROOM C2.5 & C2.6	42

LEGEND

- Circulation back of house
- Circulation front of house
- Lifts
- Fire hydrant
- Toilets / facilities
- Business Suite 2
- Meeting Rooms, Parkside Ballroom and Gallery
- Darling Harbour Theatre Facilities

* Standard capacity illustrated. Higher capacities can be achieved with less staging and AV services and reduced furniture spacing. Please consider your event requirements when viewing capacities.

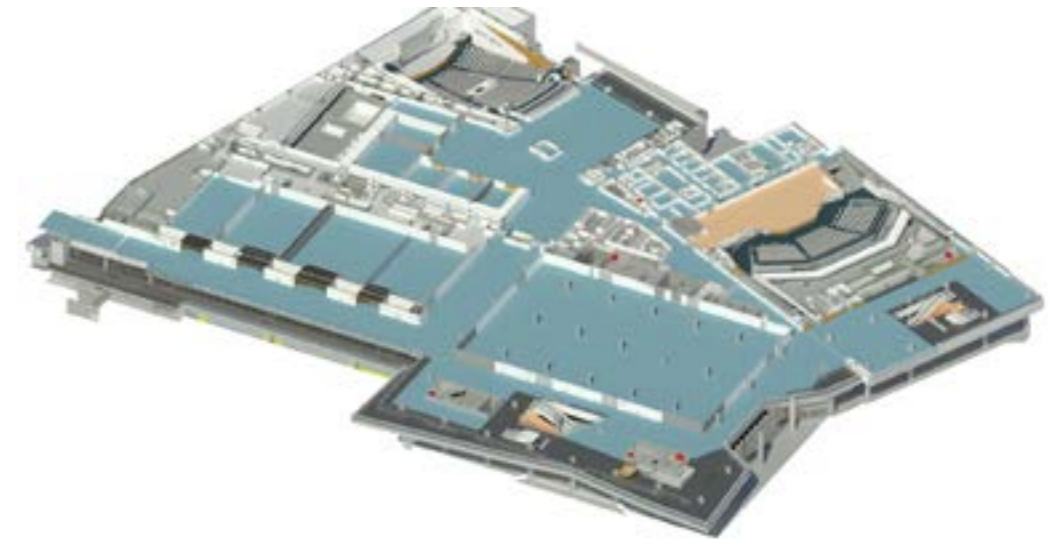
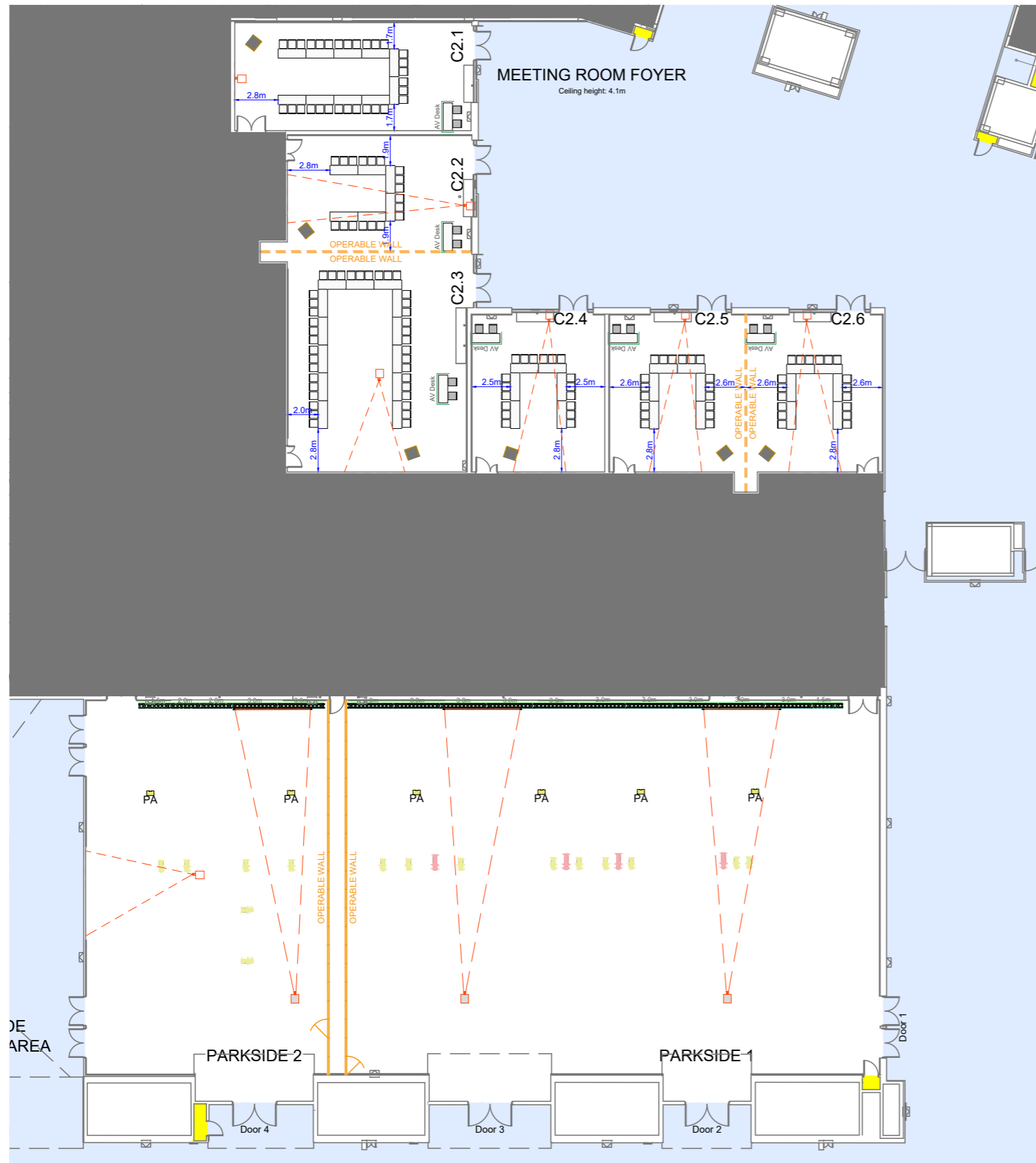

Axonometric cutaway view of Level 2 Convention Centre

ROOM NAME	U SHAPE
MEETING ROOM C2.1	30
MEETING ROOM C2.2	18
MEETING ROOM C2.3	39
MEETING ROOM C2.2 & C2.3	63
MEETING ROOM C2.4	18
MEETING ROOM C2.5	18
MEETING ROOM C2.6	18
MEETING ROOM C2.5 & C2.6	33

LEGEND

- Circulation back of house
- Circulation front of house
- Lifts
- Fire hydrant
- Toilets / facilities
- Business Suite 2
- Meeting Rooms, Parkside Ballroom and Gallery
- Darling Harbour Theatre Facilities

* Standard capacity illustrated. Higher capacities can be achieved with less staging and AV services and reduced furniture spacing. Please consider your event requirements when viewing capacities.

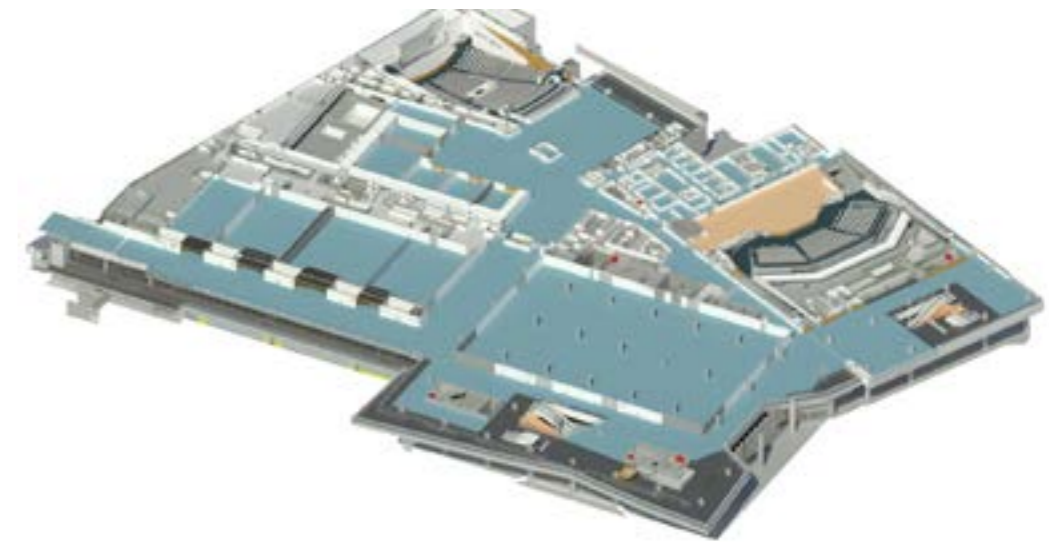
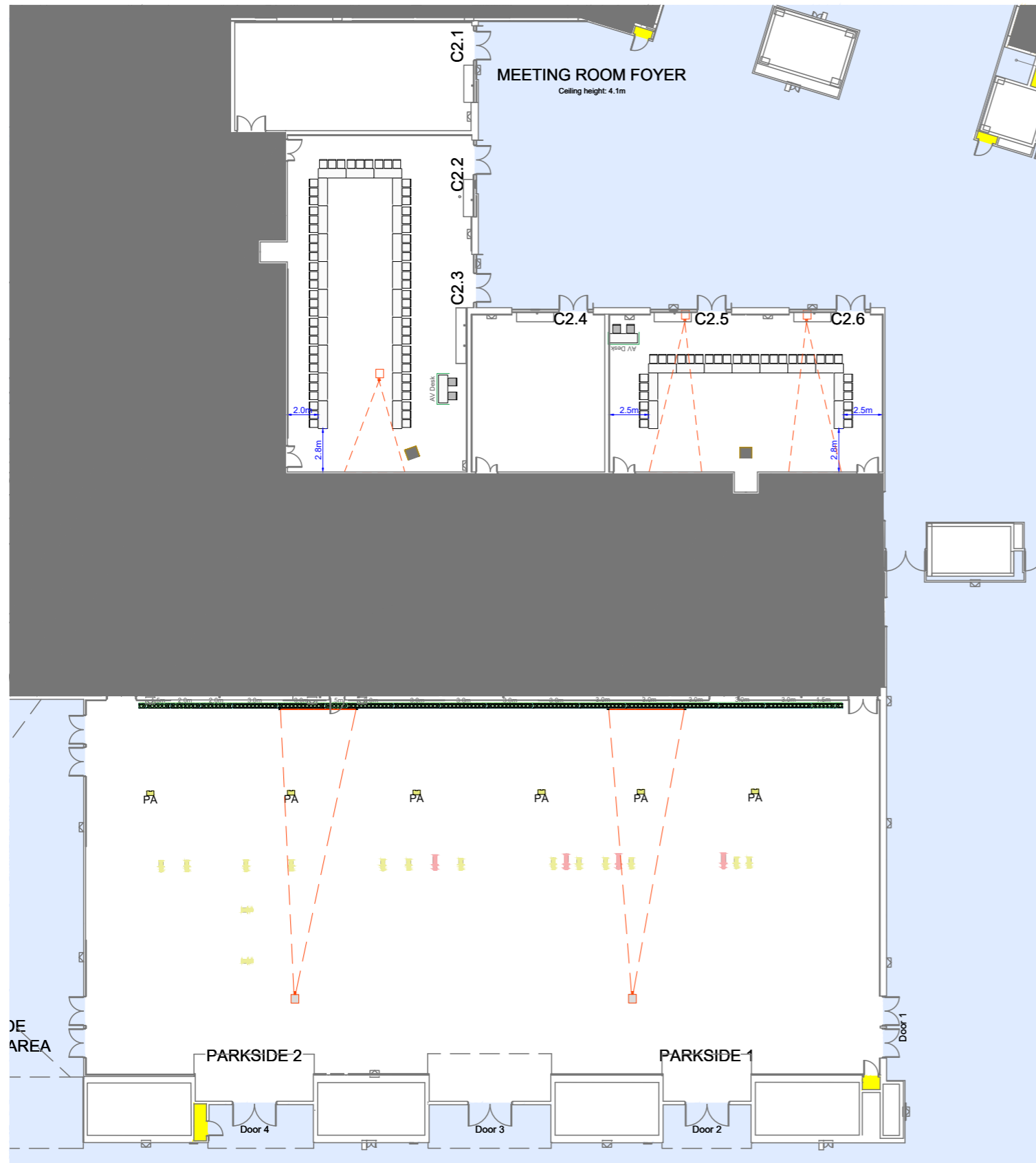

Axonometric cutaway view of Level 2 Convention Centre

ROOM NAME	U SHAPE
MEETING ROOM C2.1	30
MEETING ROOM C2.2	18
MEETING ROOM C2.3	39
MEETING ROOM C2.2 & C2.3	63
MEETING ROOM C2.4	18
MEETING ROOM C2.5	18
MEETING ROOM C2.6	18
MEETING ROOM C2.5 & C2.6	33

LEGEND

- Circulation back of house
- Circulation front of house
- Lifts
- Fire hydrant
- Toilets / facilities
- Business Suite 2
- Meeting Rooms, Parkside Ballroom and Gallery
- Darling Harbour Theatre Facilities

* Standard capacity illustrated. Higher capacities can be achieved with less staging and AV services and reduced furniture spacing. Please consider your event requirements when viewing capacities.

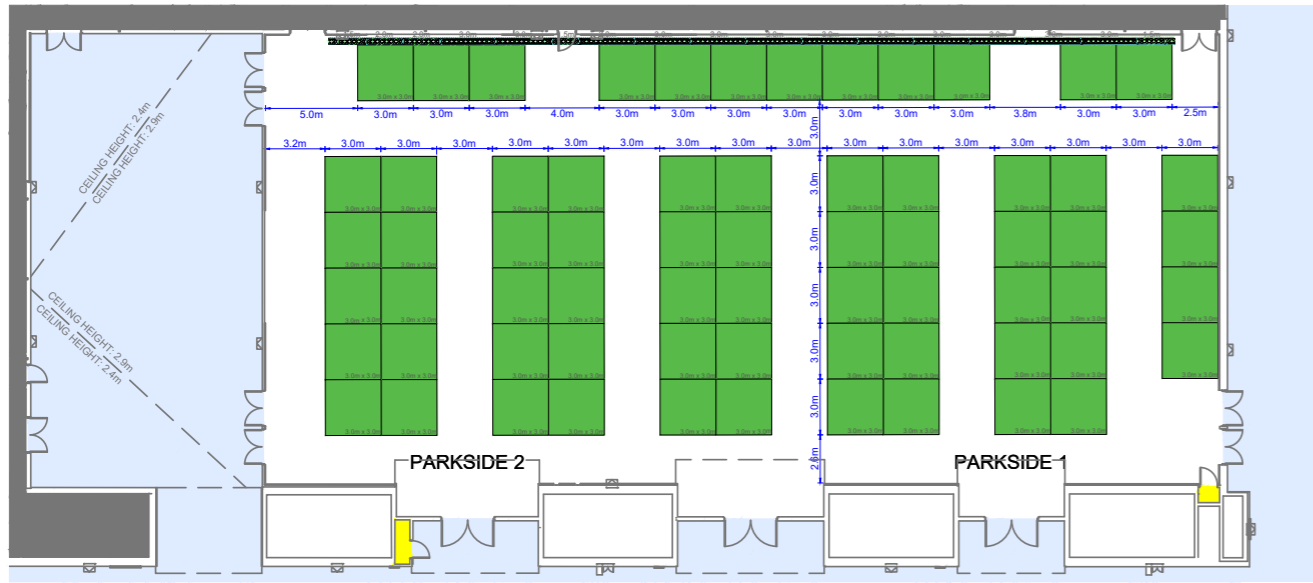

ROOM NAME	EXHIBITION
	3m x 3m
PARKSIDE BALLROOM	66
PARKSIDE BALLROOM 1	43
PARKSIDE BALLROOM 2	19
THE GALLERY	103

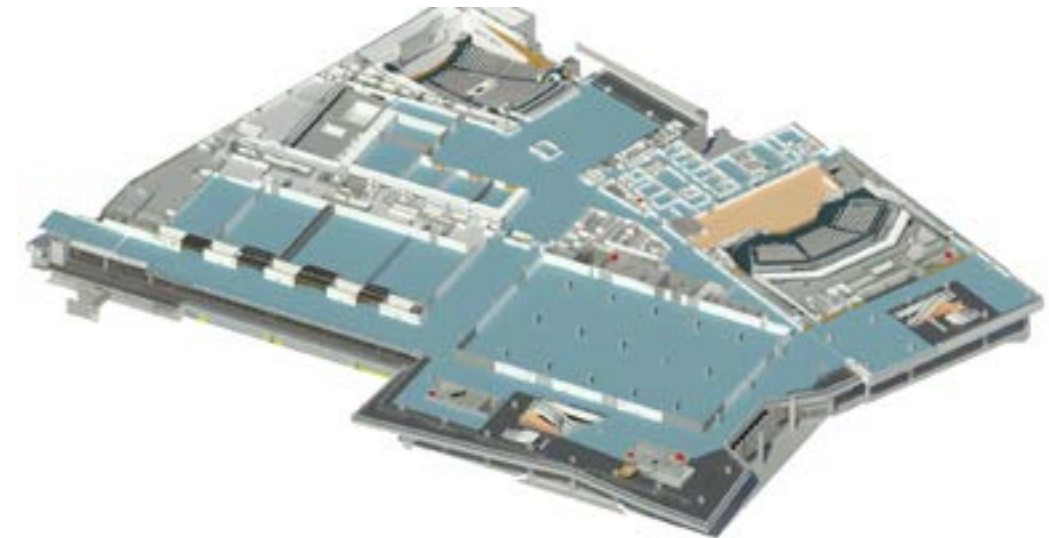

Parkside Ballroom combined mode

Axonometric cutaway view of Level 2 Convention Centre

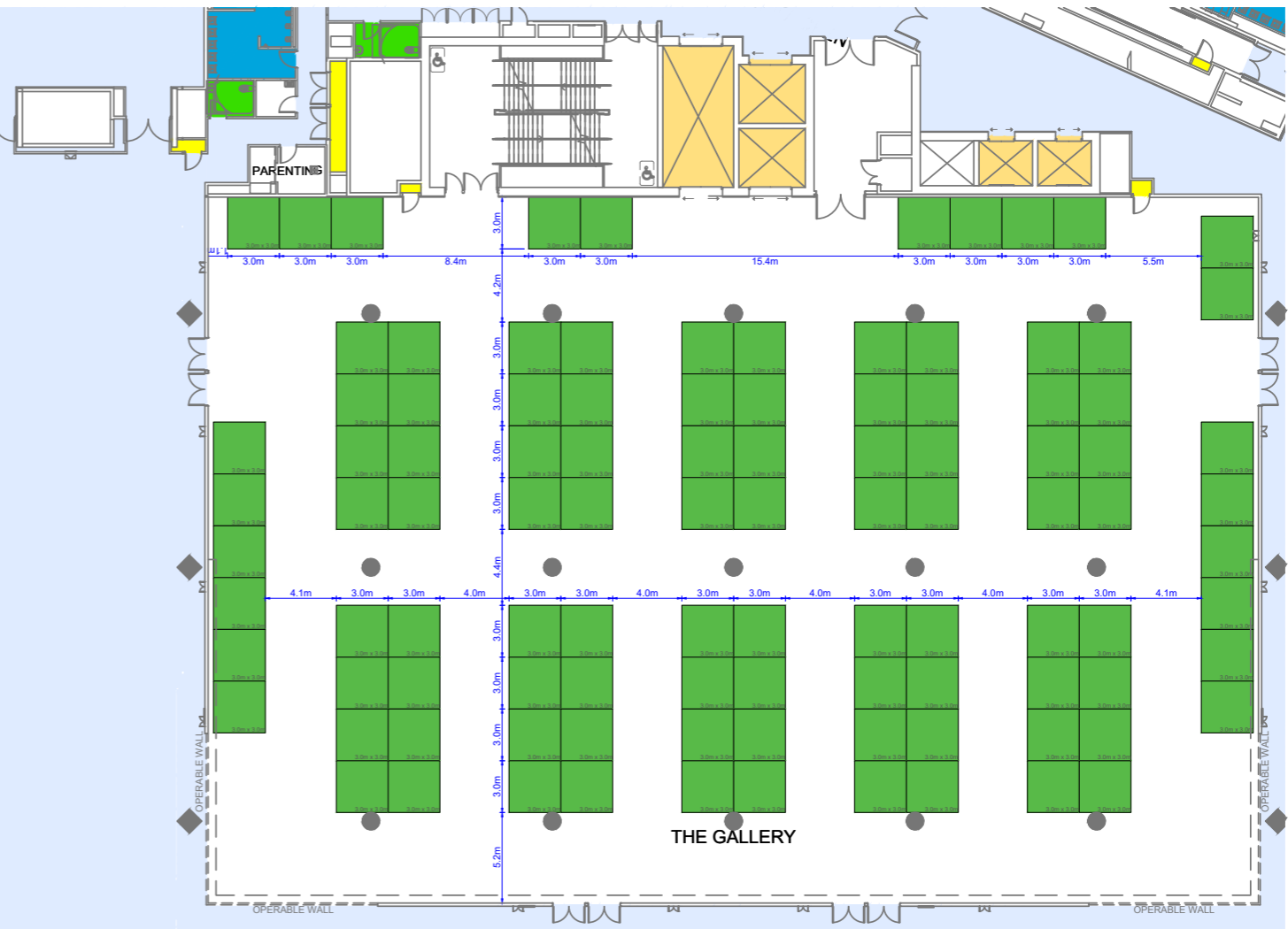
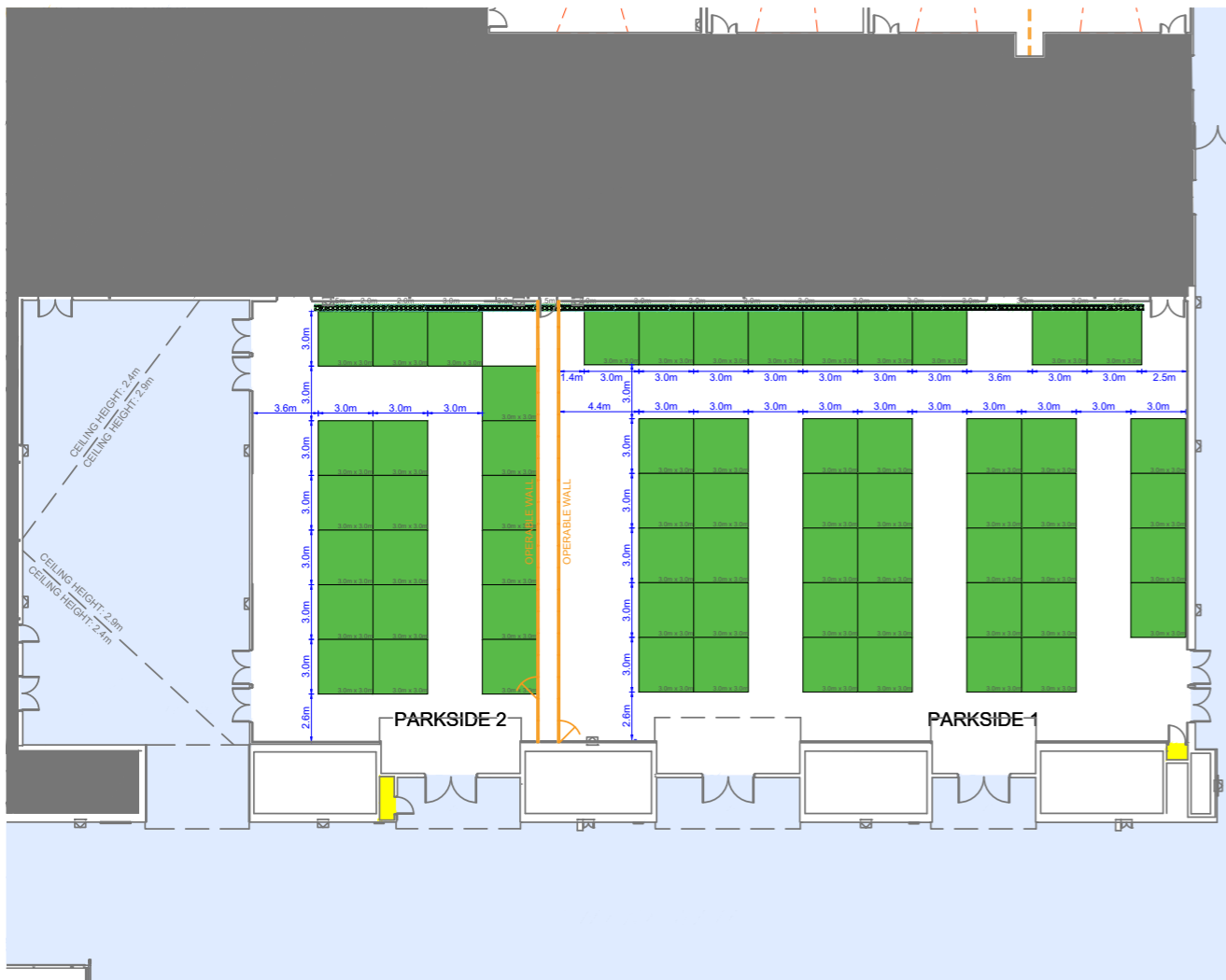

Parkside Ballroom combined mode

The Gallery

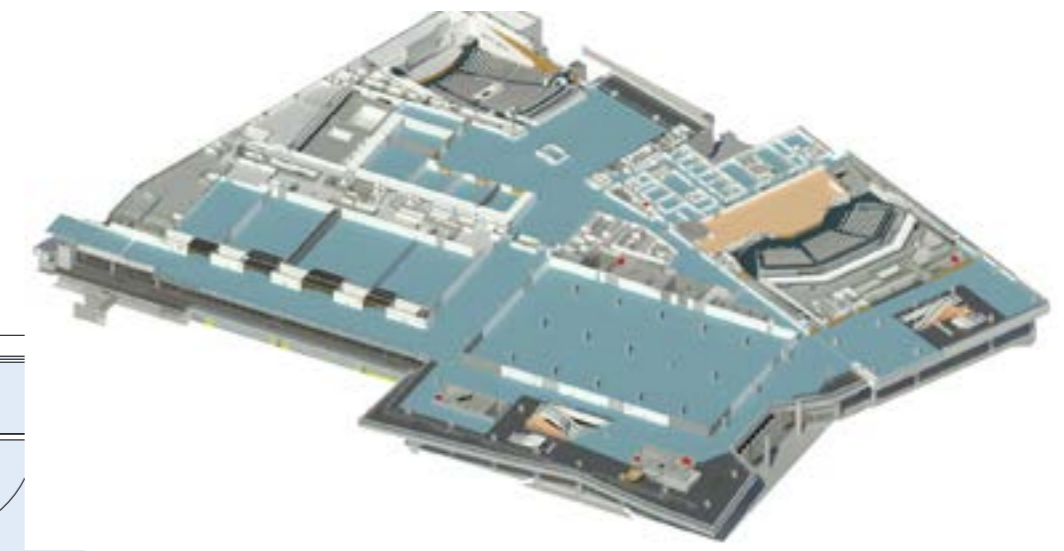
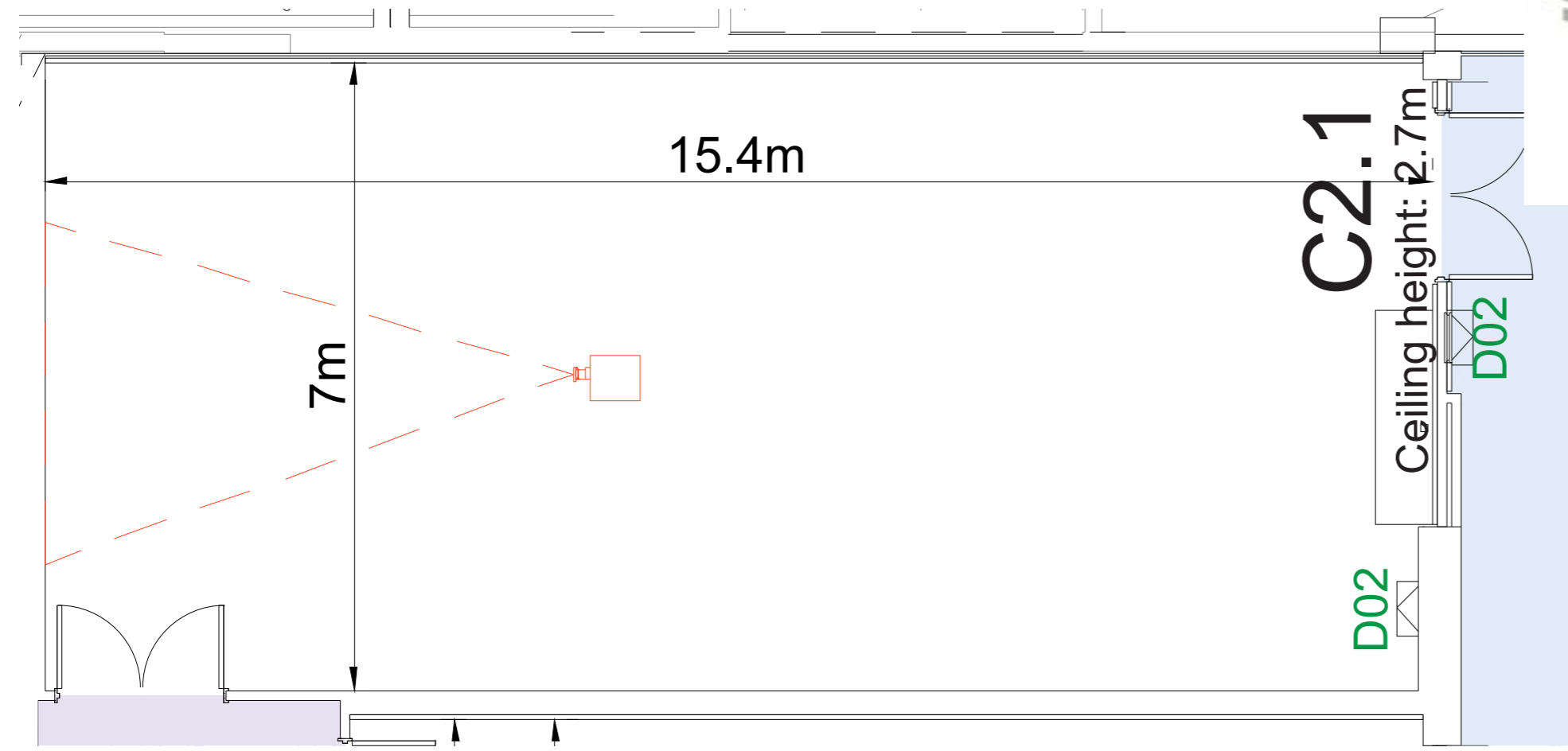

Axonometric cutaway view of Level 2 Convention Centre

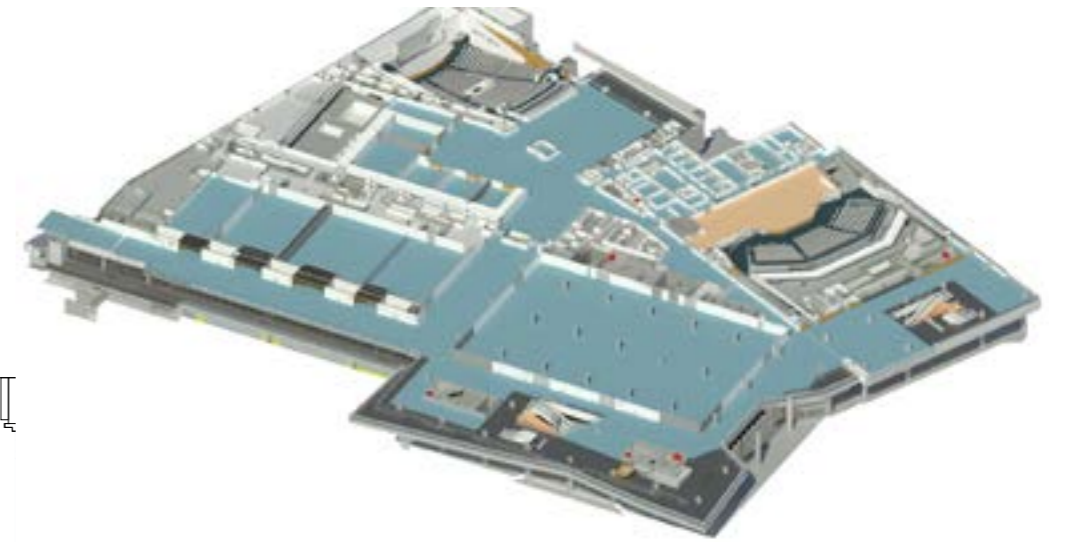
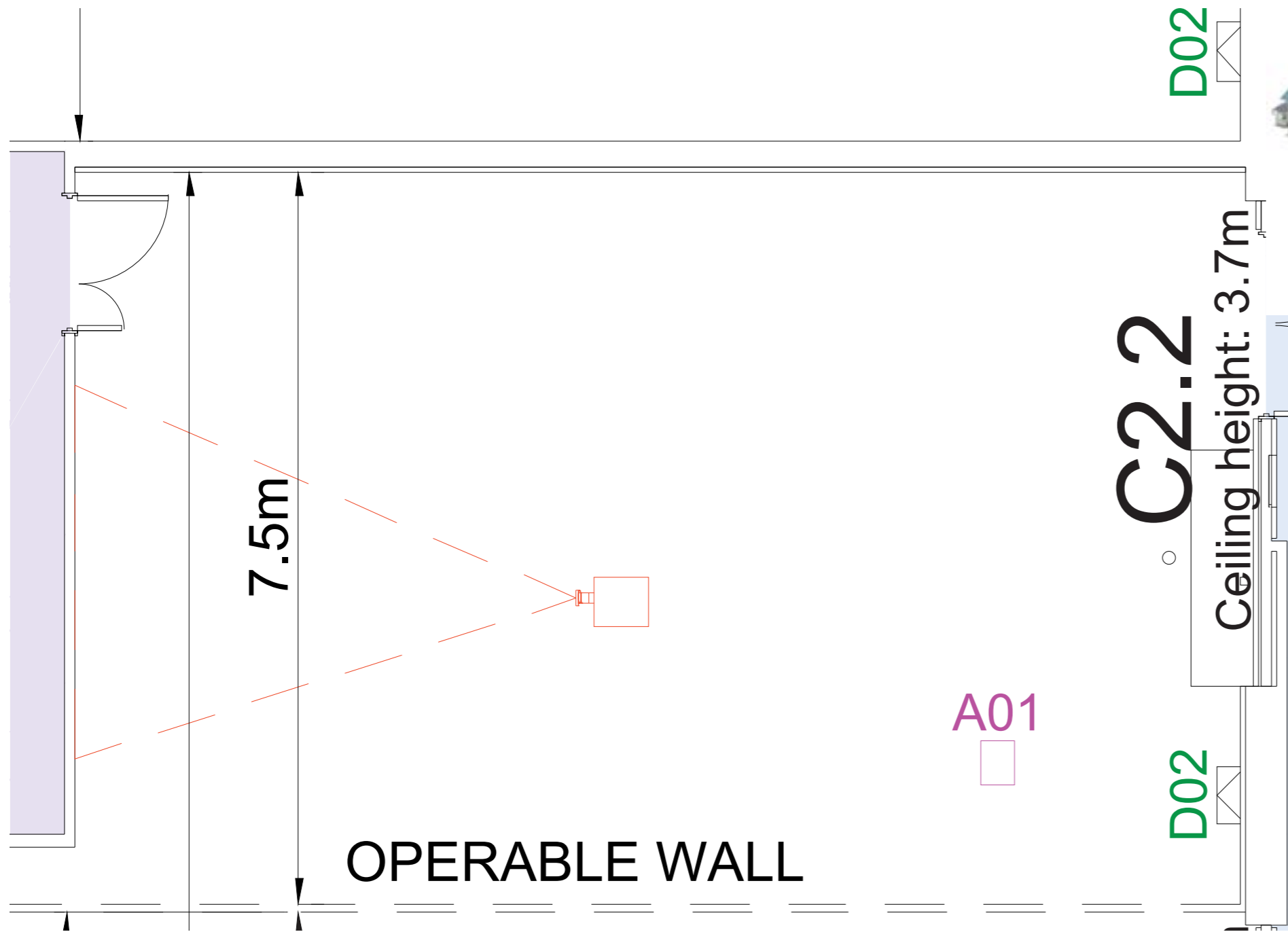

Axonometric cutaway view of Level 2 Convention Centre

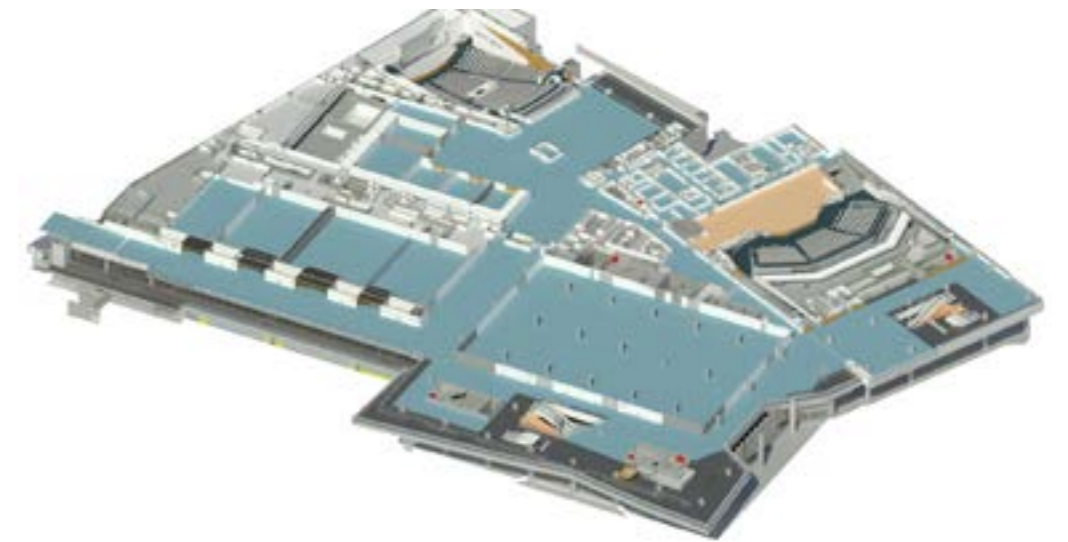
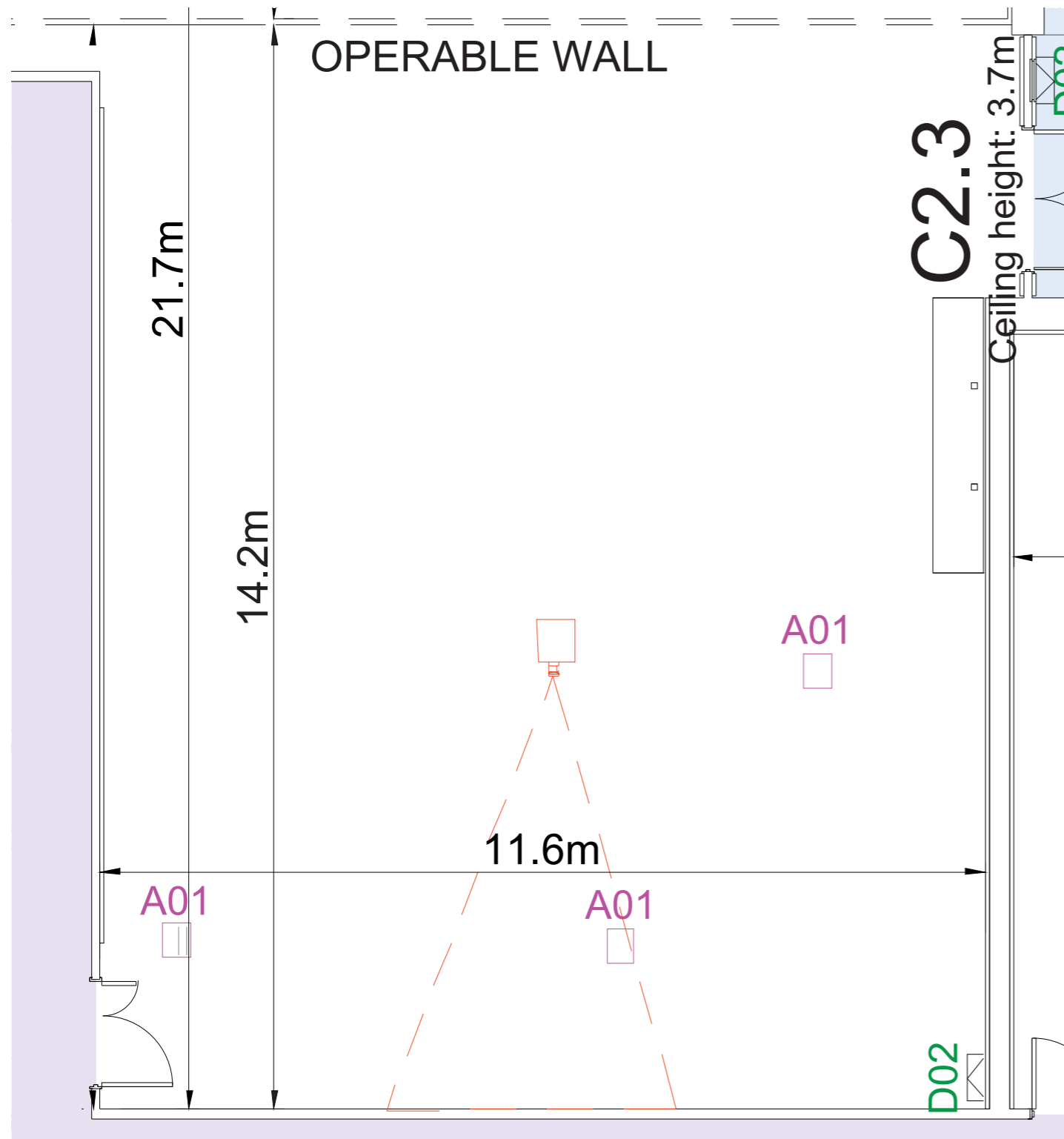

Axonometric cutaway view of Level 2 Convention Centre

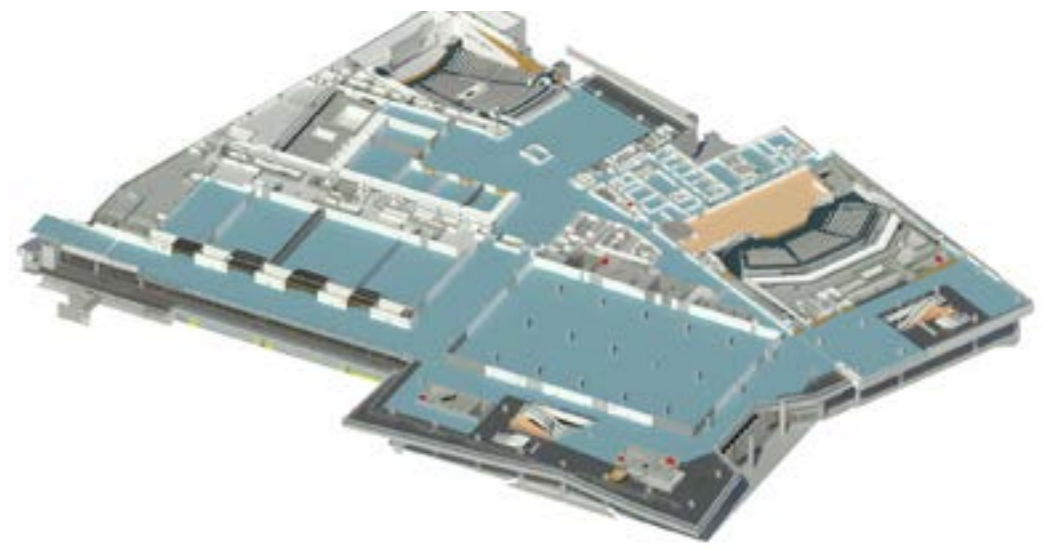
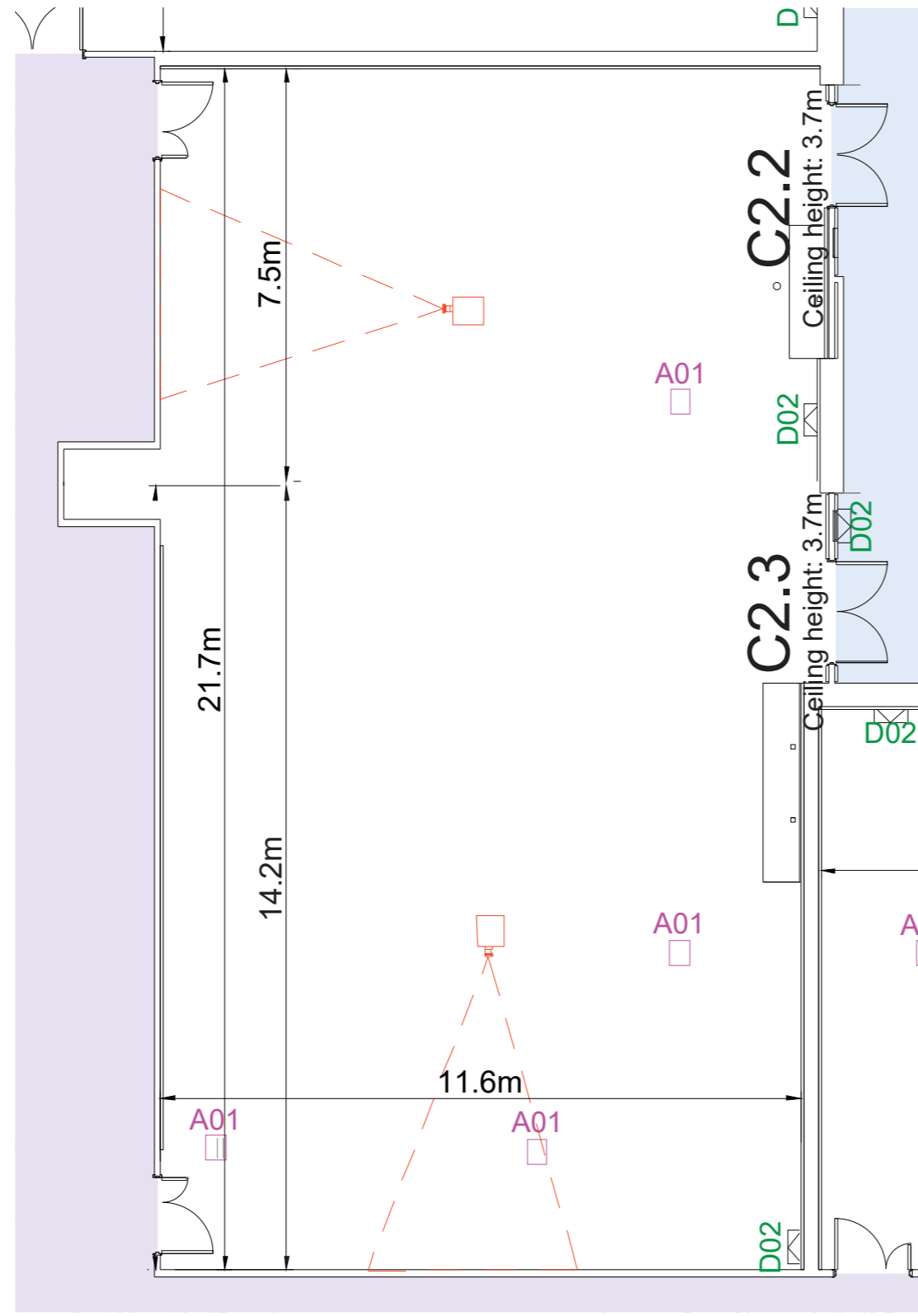

Axonometric cutaway view of Level 2 Convention Centre

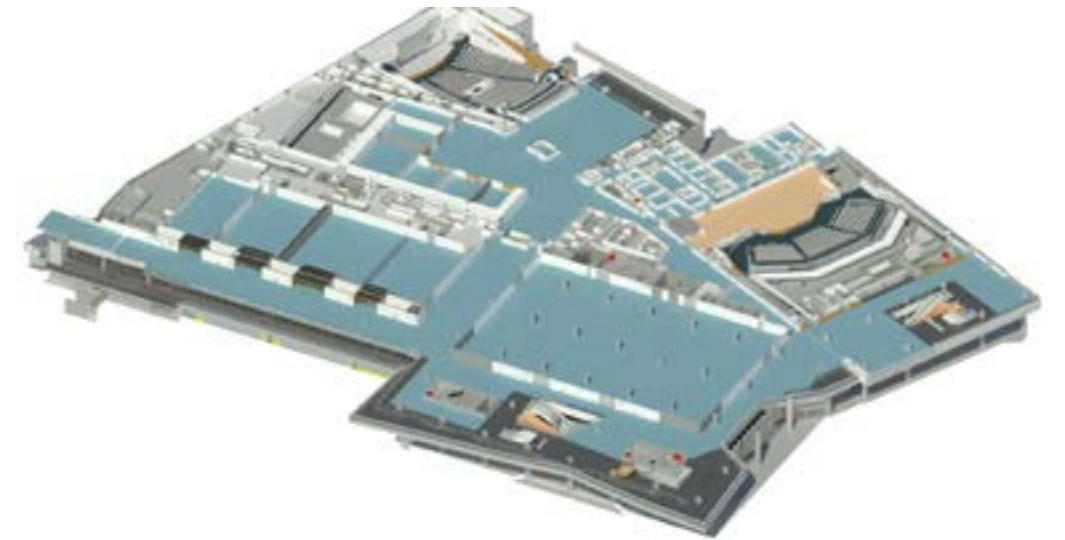
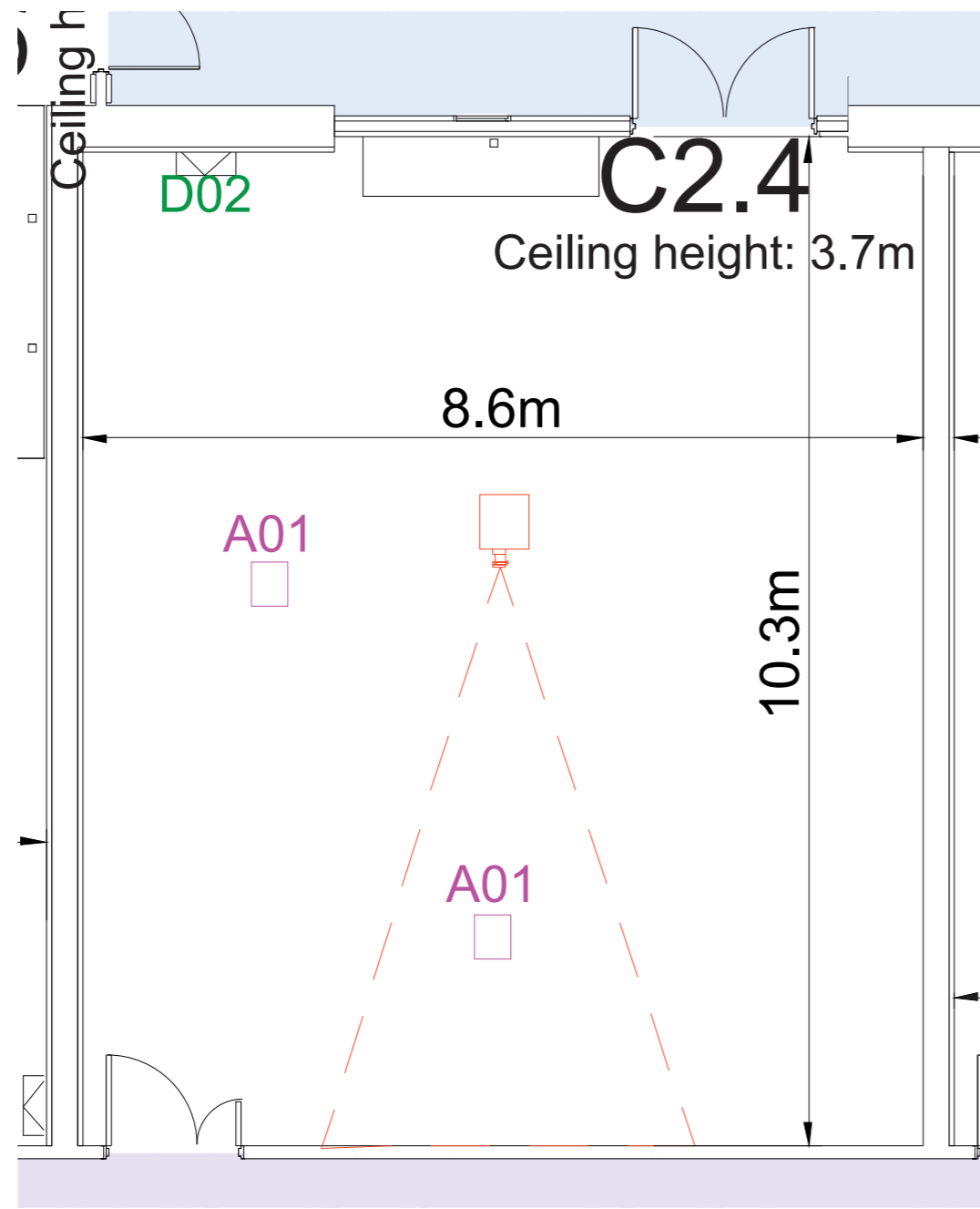

Axonometric cutaway view of Level 2 Convention Centre

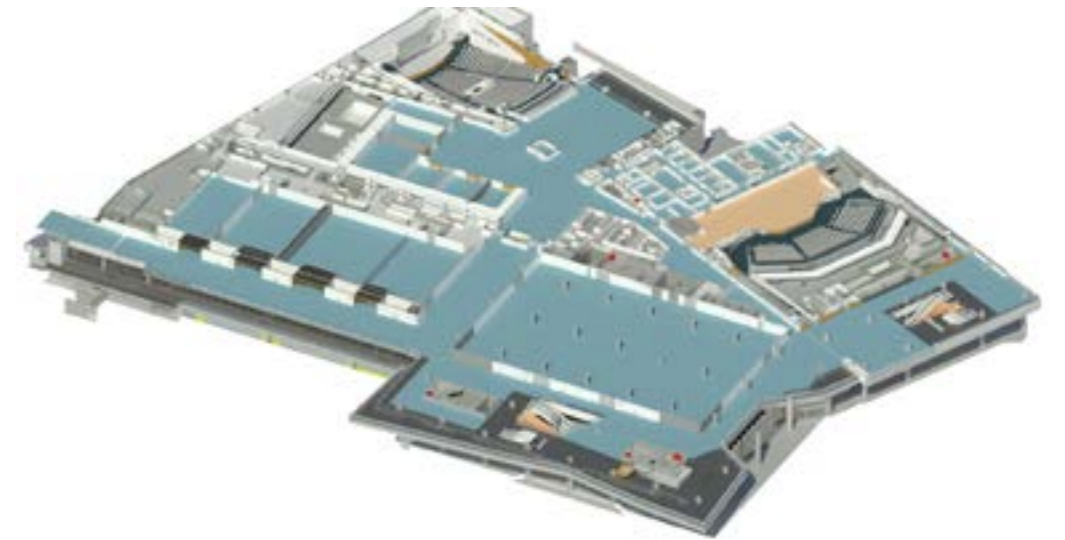
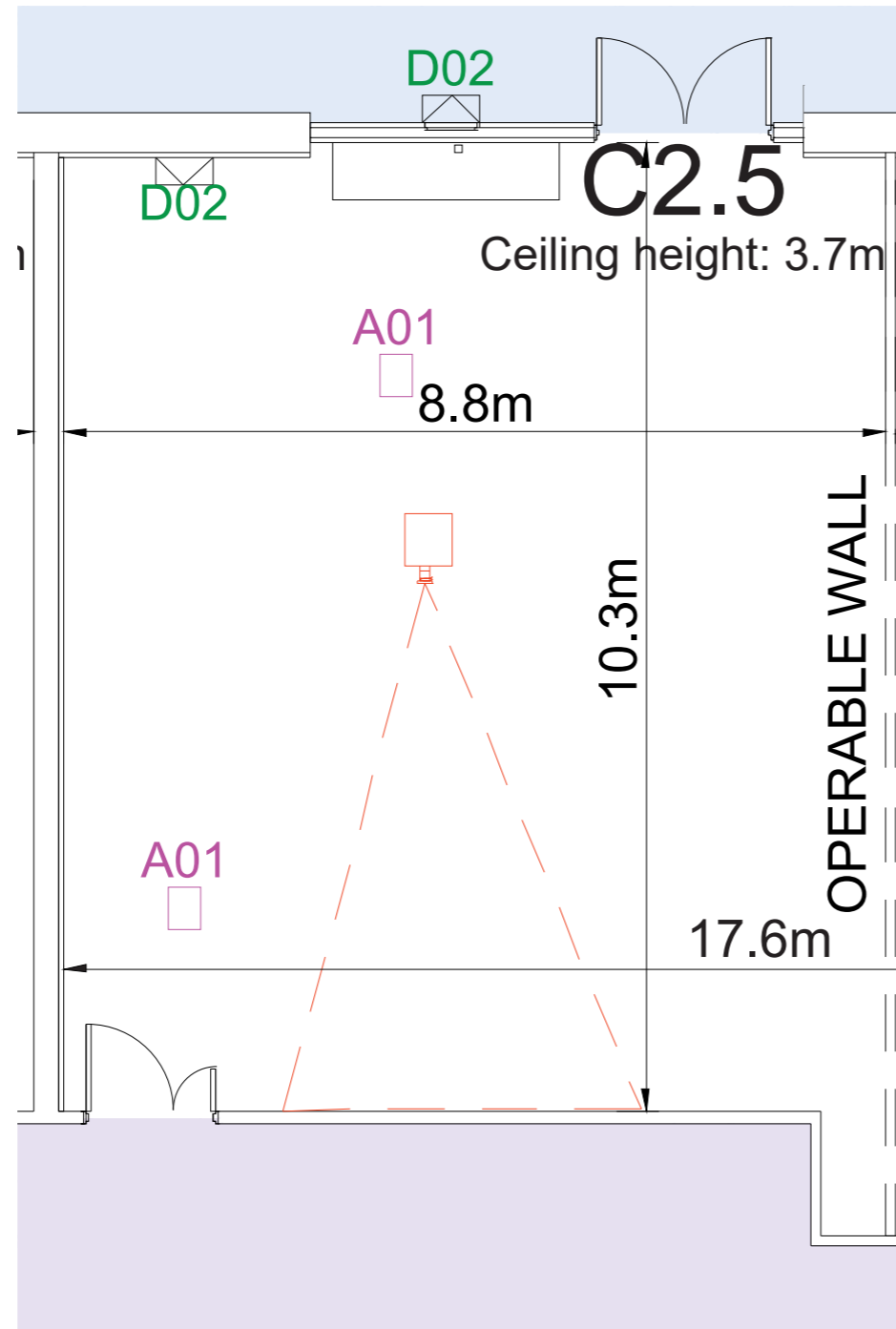

Axonometric cutaway view of Level 2 Convention Centre

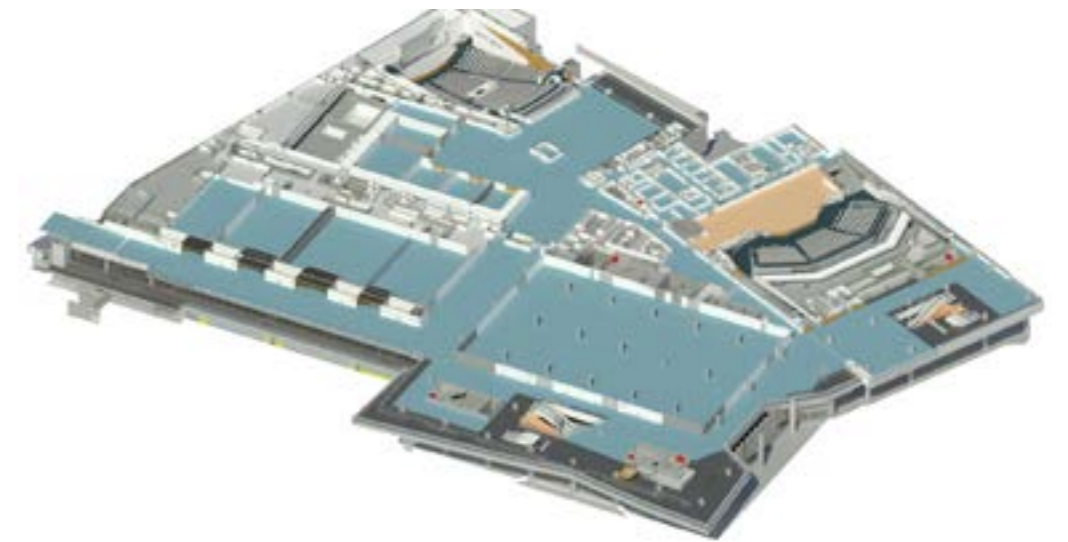
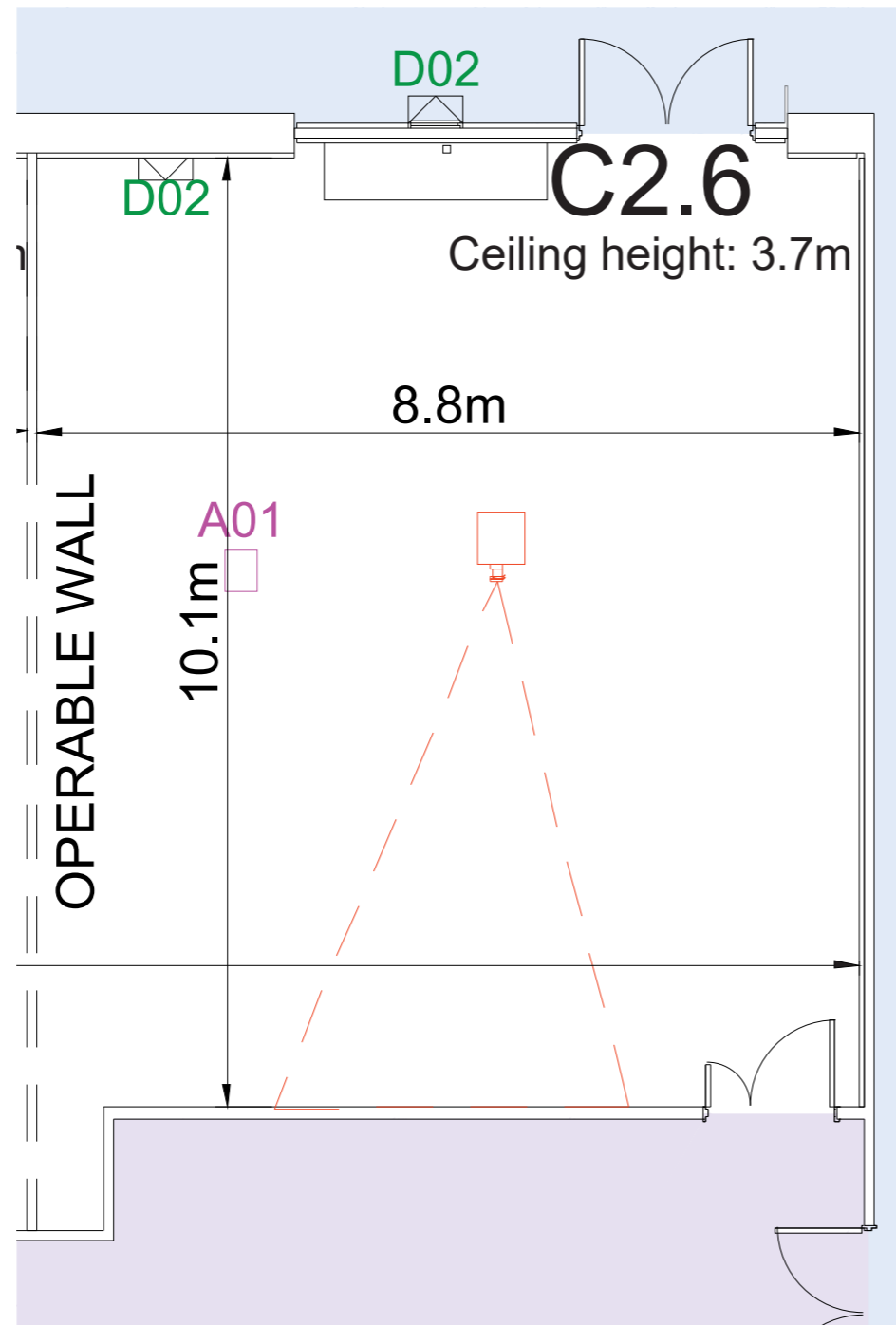

Axonometric cutaway view of Level 2 Convention Centre

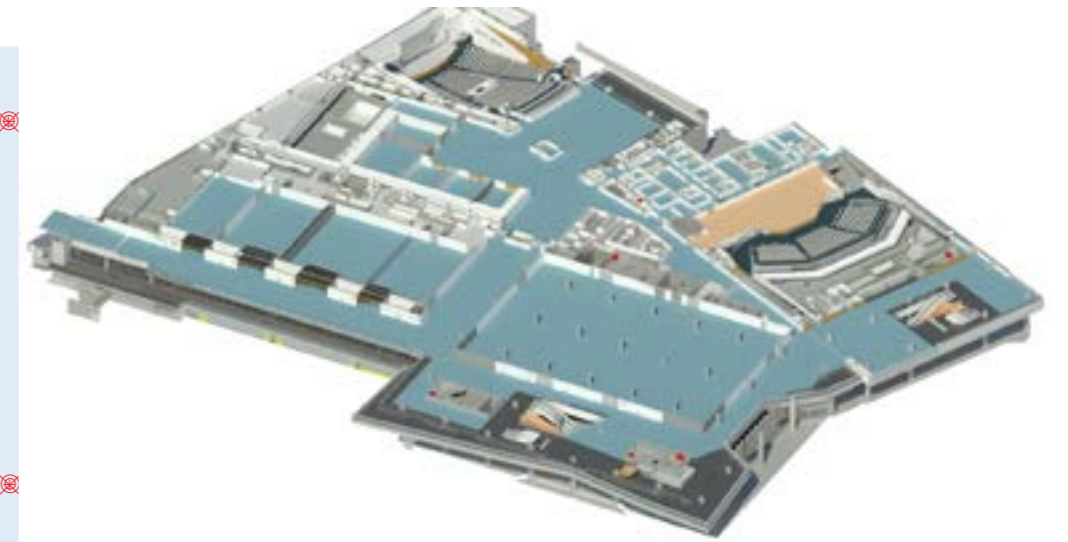
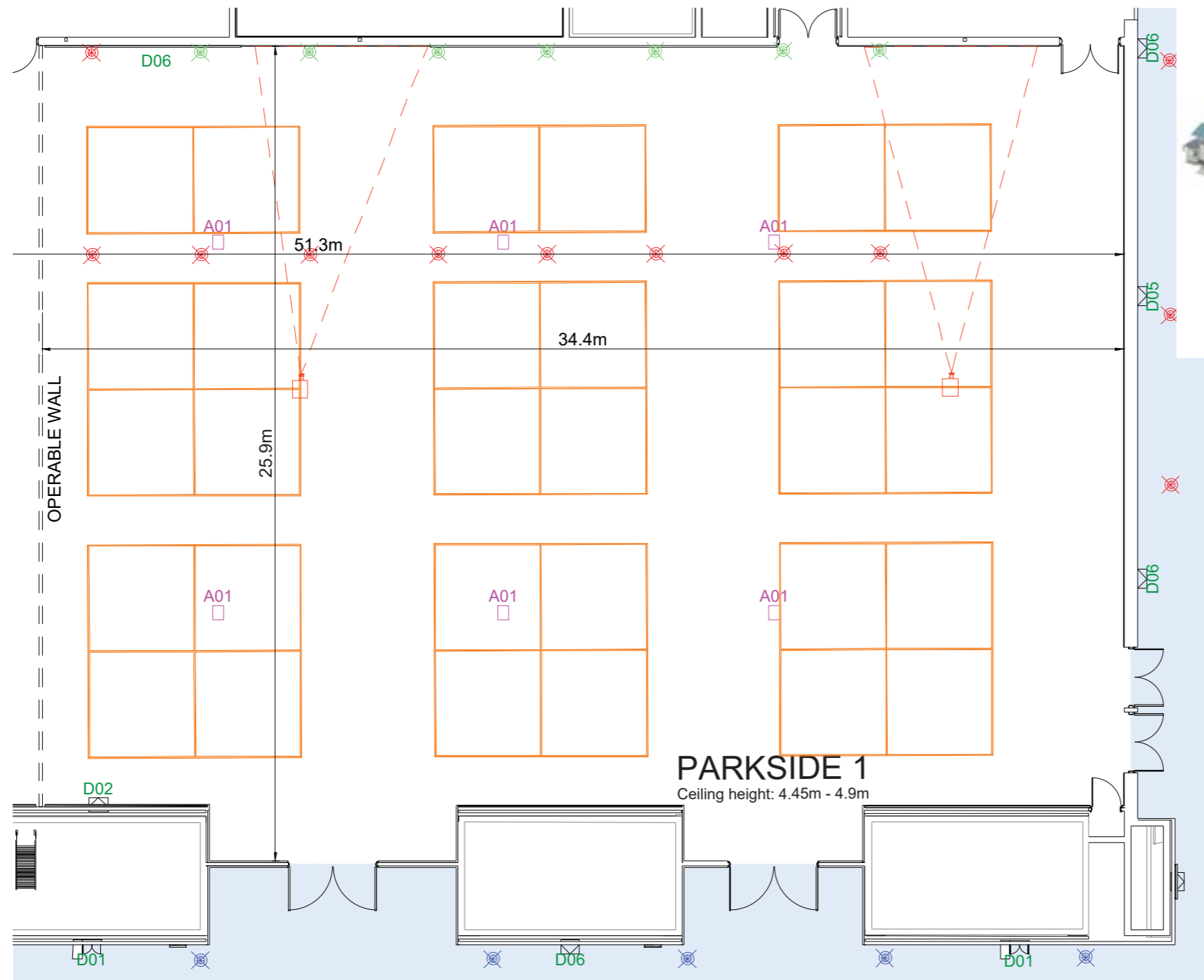

Axonometric cutaway view of Level 2 Convention Centre

- D05 Service Cupboard 05
1 x DGPO
1 x 32A 3PH
2 x SINGLE DATA
- D06 Service Cupboard 06
1 x DGPO
1 x 20A SGPO
2 x SINGLE DATA
- ⊗ Rigging Point 1.0T
- ⊗ Rigging Point 0.5T
- ⊗ Rigging Point 0.25T
- ⊗ Rigging Point 0.15T
- Rigging Bar 100kg/lm
- Projector

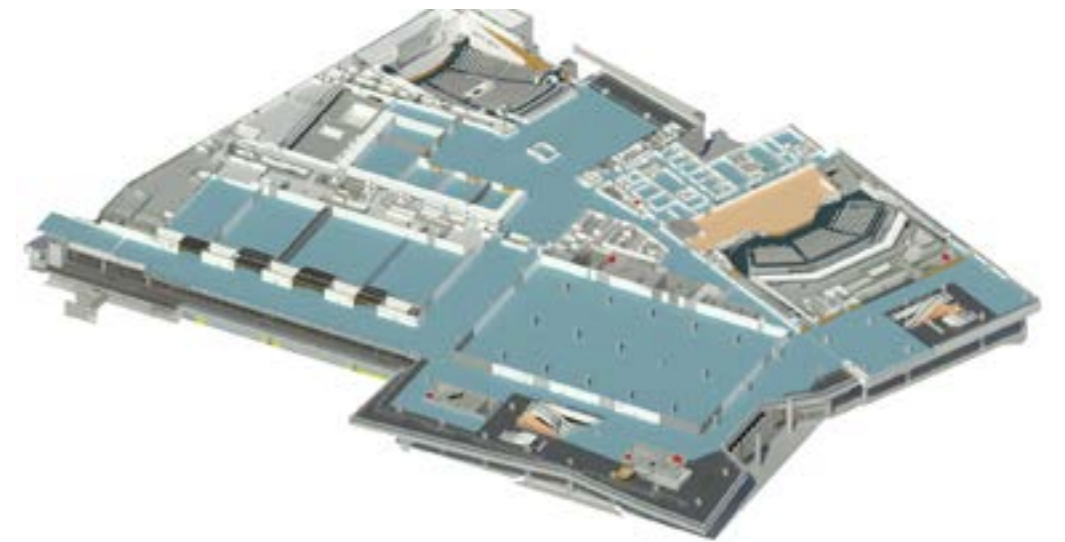
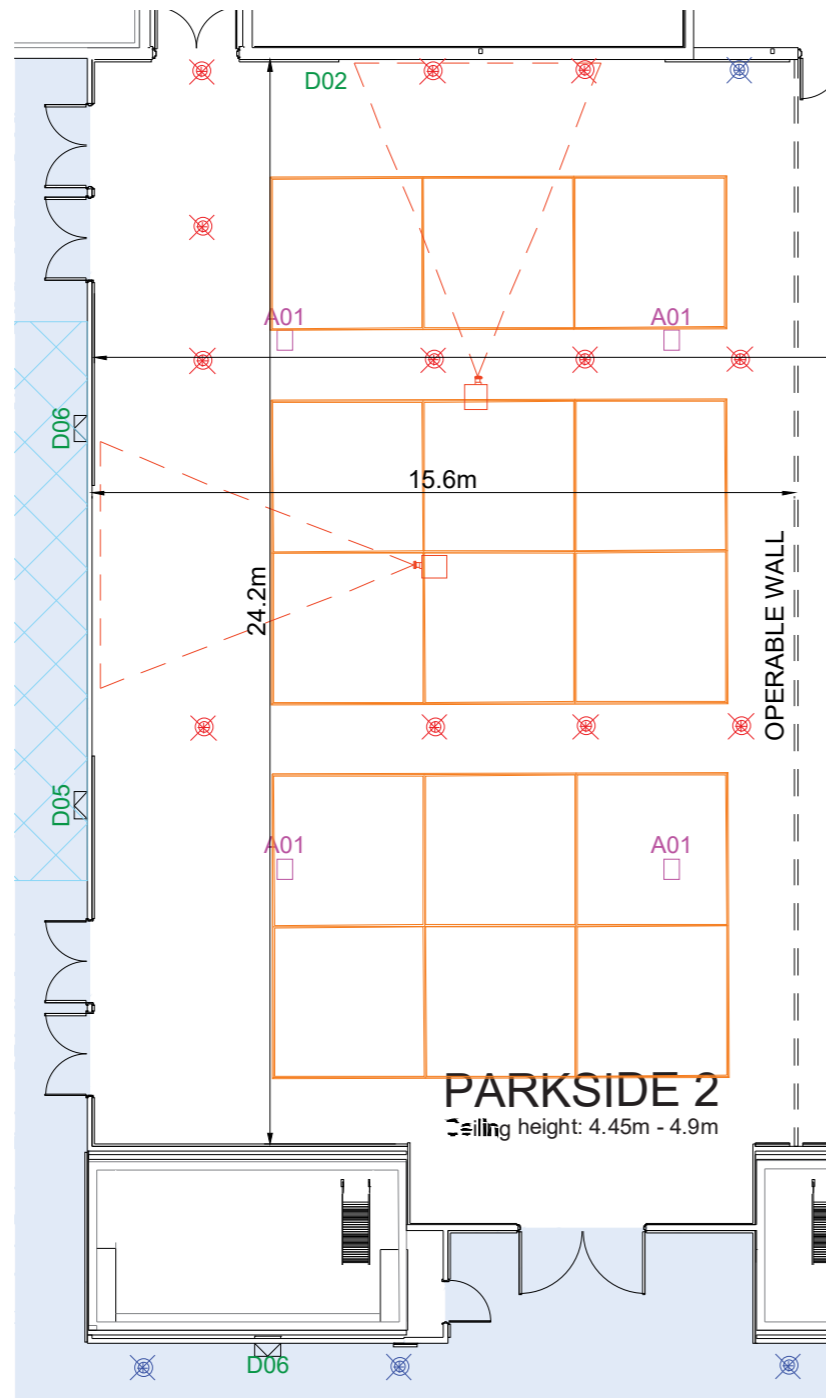

Axonometric cutaway view of Level 2 Convention Centre

- D05 Service Cupboard 05
1 x DGPO
1 x 32A 3PH
2 x SINGLE DATA
- D06 Service Cupboard 06
1 x DGPO
1 x 20A SGPO
2 x SINGLE DATA
- Rigging Point 1.0T
- Rigging Point 0.5T
- Rigging Point 0.25T
- Rigging Point 0.15T
- Rigging Bar 100kg/m
- Projector

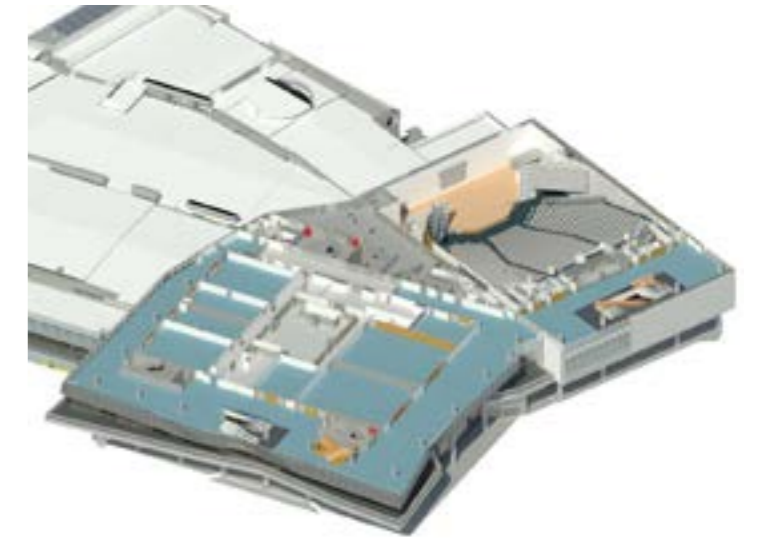
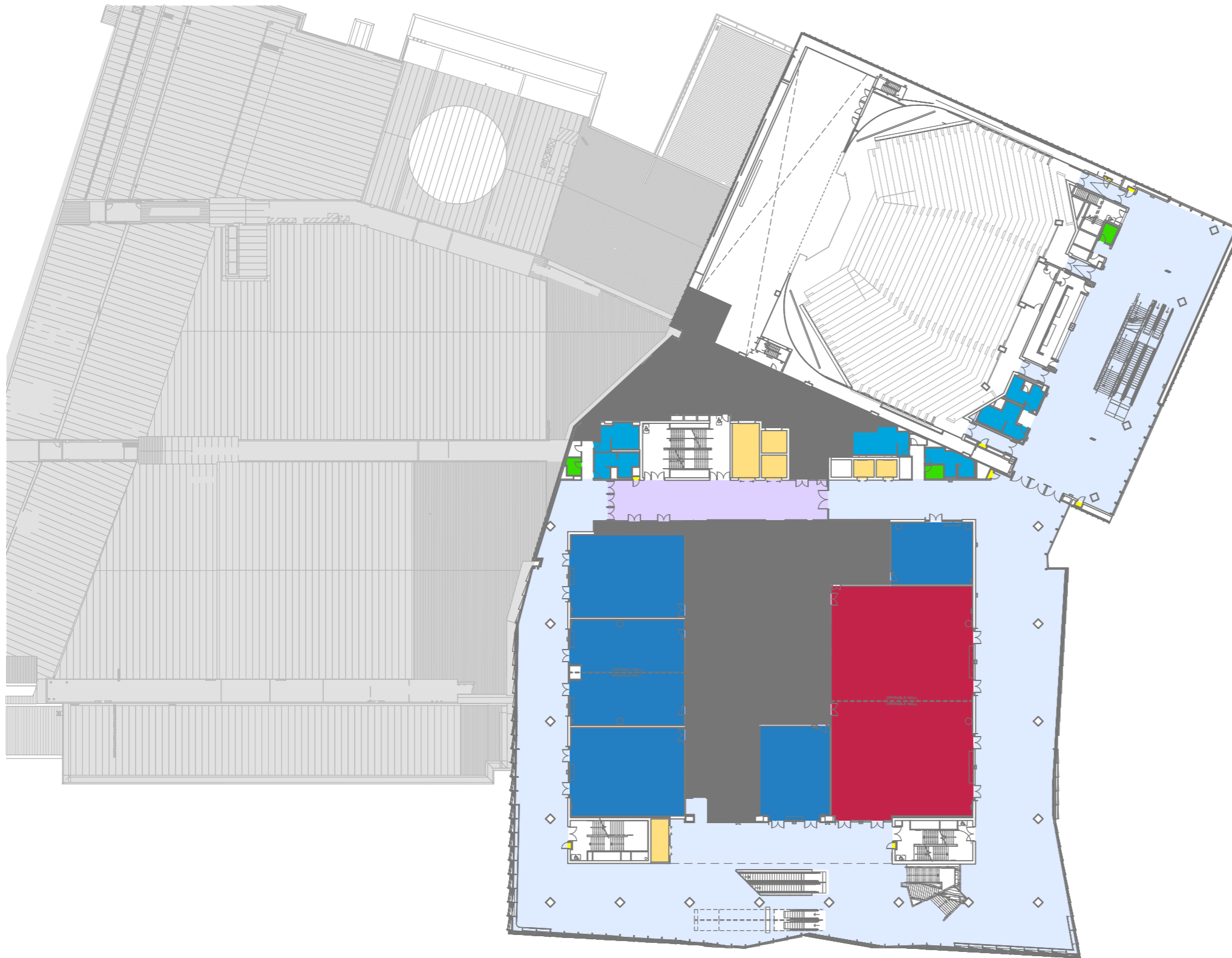

Axonometric cutaway view of Level 3 Convention Centre

LEGEND

- Back of House
- Circulation Back of House
- Circulation Front of House
- Lifts
- Fire Hydrants
- Toilets / Facilities
- Accessible Toilet
- Rooms C3.1 - C3.6
- Cockle Bay Room

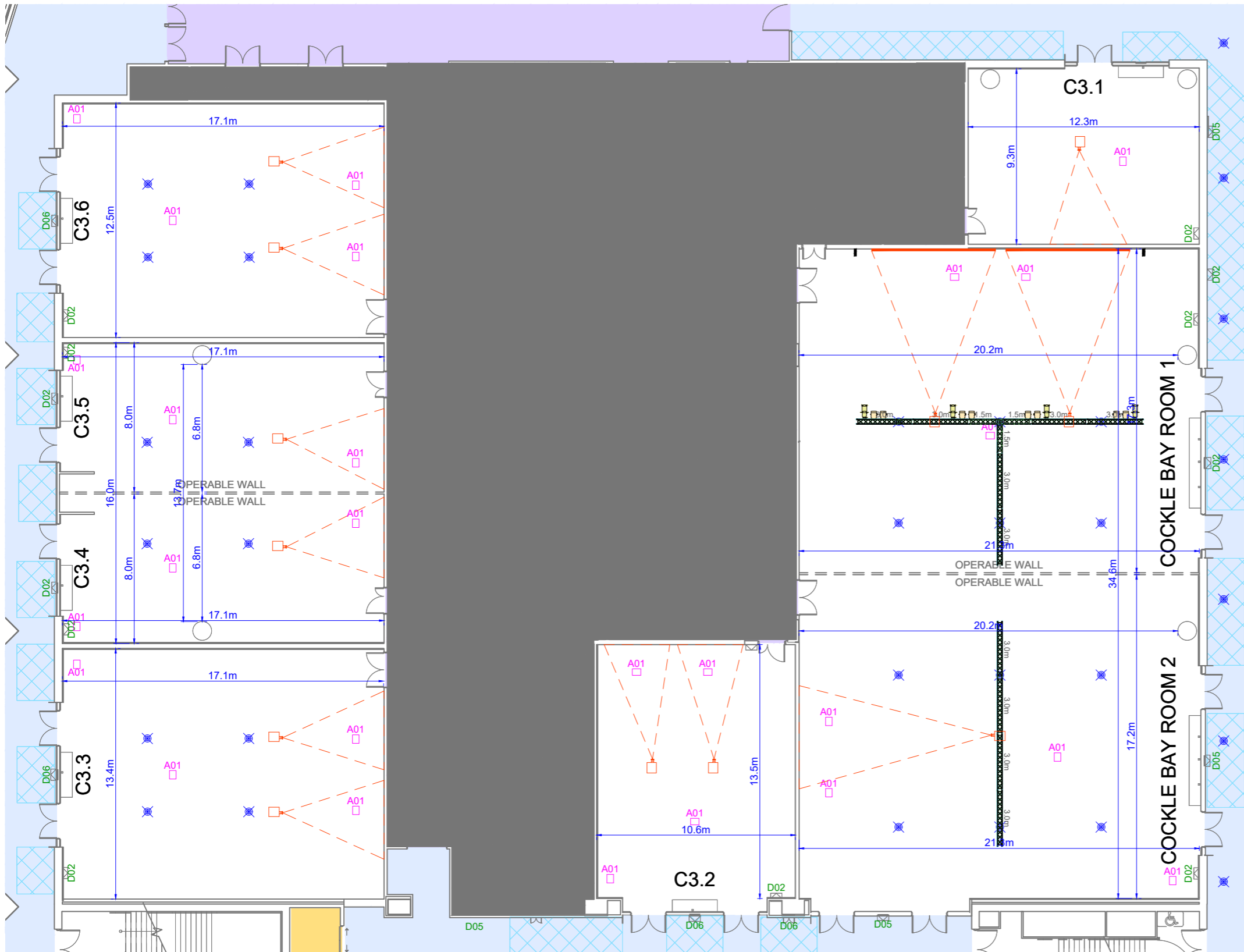

Axonometric cutaway view of Level 3 Convention Centre

LEGEND

- A01 Floor Box Type A01
6 x SGPO
2 x SINGLE DATA
2 x SINGLE DATA SUPPLIED AND INSTALLED BY AV CONTRACTOR
 - A07 Floor Box Type A07
2 x 15A SGPO
1 x 32A 3PH
2 x SINGLE DATA
 - A09 Floor Box Type A09
2 x SGPO
1 x 20A SGPO
2 x SINGLE DATA
 - A10 Floor Box Type A10
2 x SGPO
1 x 32A 3PH
2 x SINGLE DATA
 - D02 Service Cupboard 02
2 x DGPO
1 x 32A 3PH
4 x SINGLE DATA
1 x 6C SMOF
 - D05 Service Cupboard 05
1 x DGPO
1 x 32A 3PH
2 x SINGLE DATA
 - D06 Service Cupboard 06
1 x DGPO
1 x 20A SGPO
2 x SINGLE DATA
 - ⊗ Rigging Point 1.0T
 - Projector
 - ⊗ Public Space Build Zone
- Back of House
 - Circulation Back of House
 - Circulation Front of House
 - Lifts

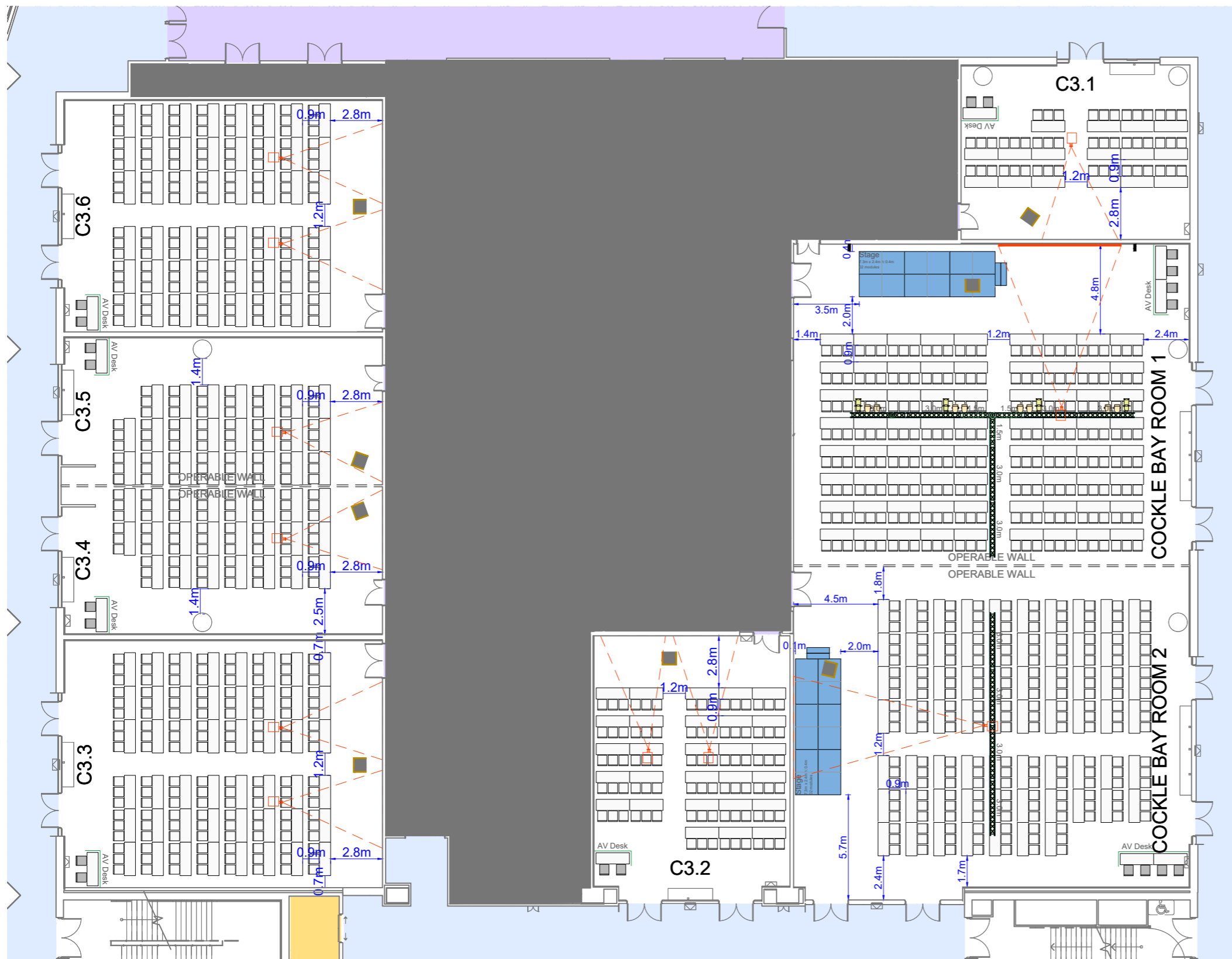

Axonometric cutaway view of Level 3 Convention Centre

ROOM NAME	CLASSROOM
COCKLE BAY ROOM	480
COCKLE BAY ROOM 1	216
COCKLE BAY ROOM 2	201
MEETING ROOM C3.1	48
MEETING ROOM C3.2	84
MEETING ROOM C3.3	144
MEETING ROOM C3.4	69
MEETING ROOM C3.5	69
MEETING ROOM C3.4 & C3.5	141
MEETING ROOM C3.6	144

* Standard capacity illustrated. Higher capacities can be achieved with less staging and AV services and reduced furniture spacing. Please consider your event requirements when viewing capacities.

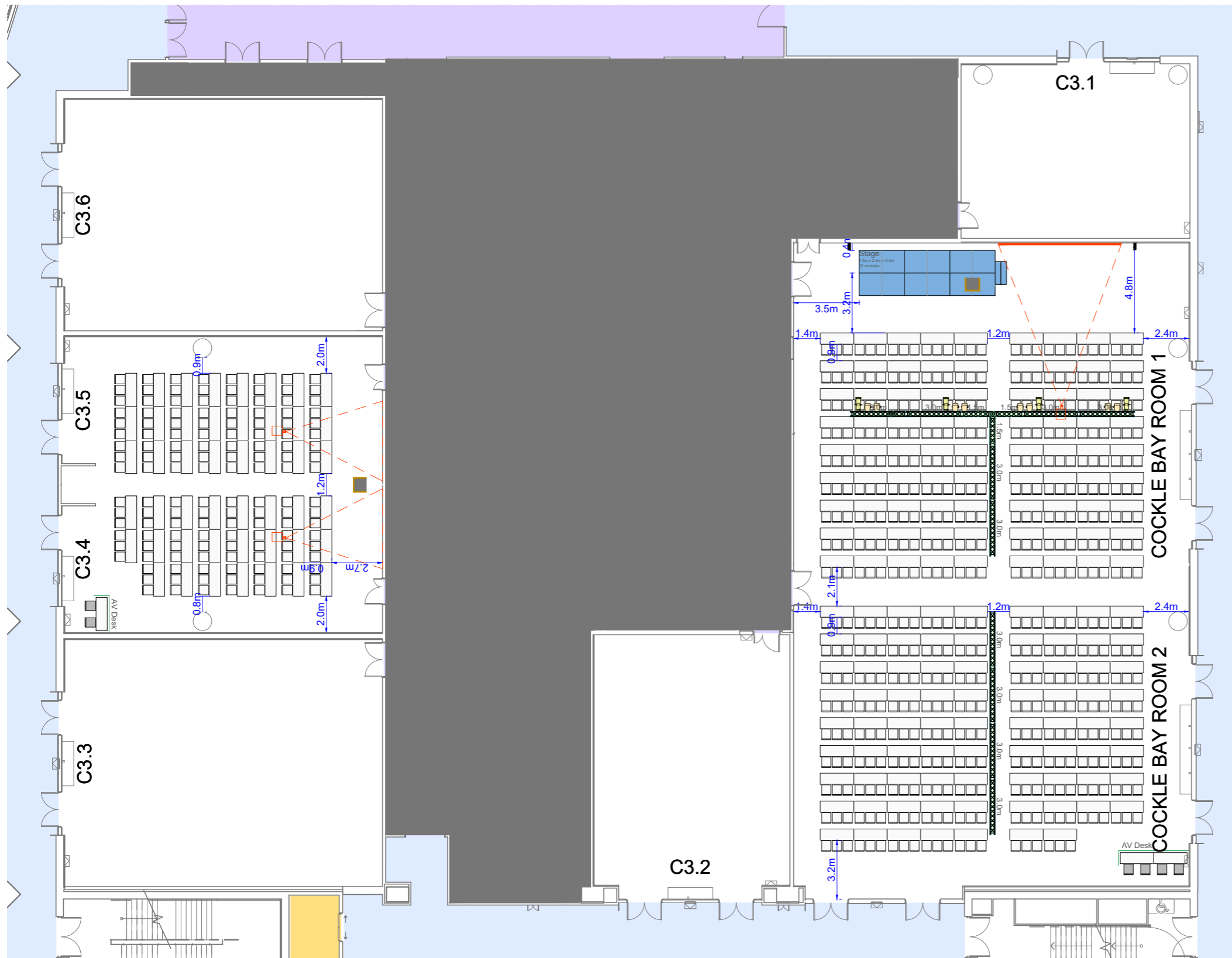

Axonometric cutaway view of Level 3 Convention Centre

ROOM NAME	CLASSROOM
COCKLE BAY ROOM	480
COCKLE BAY ROOM 1	216
COCKLE BAY ROOM 2	201
MEETING ROOM C3.1	48
MEETING ROOM C3.2	84
MEETING ROOM C3.3	144
MEETING ROOM C3.4	69
MEETING ROOM C3.5	69
MEETING ROOM C3.4 & C3.5	141
MEETING ROOM C3.6	144

* Standard capacity illustrated. Higher capacities can be achieved with less staging and AV services and reduced furniture spacing. Please consider your event requirements when viewing capacities.

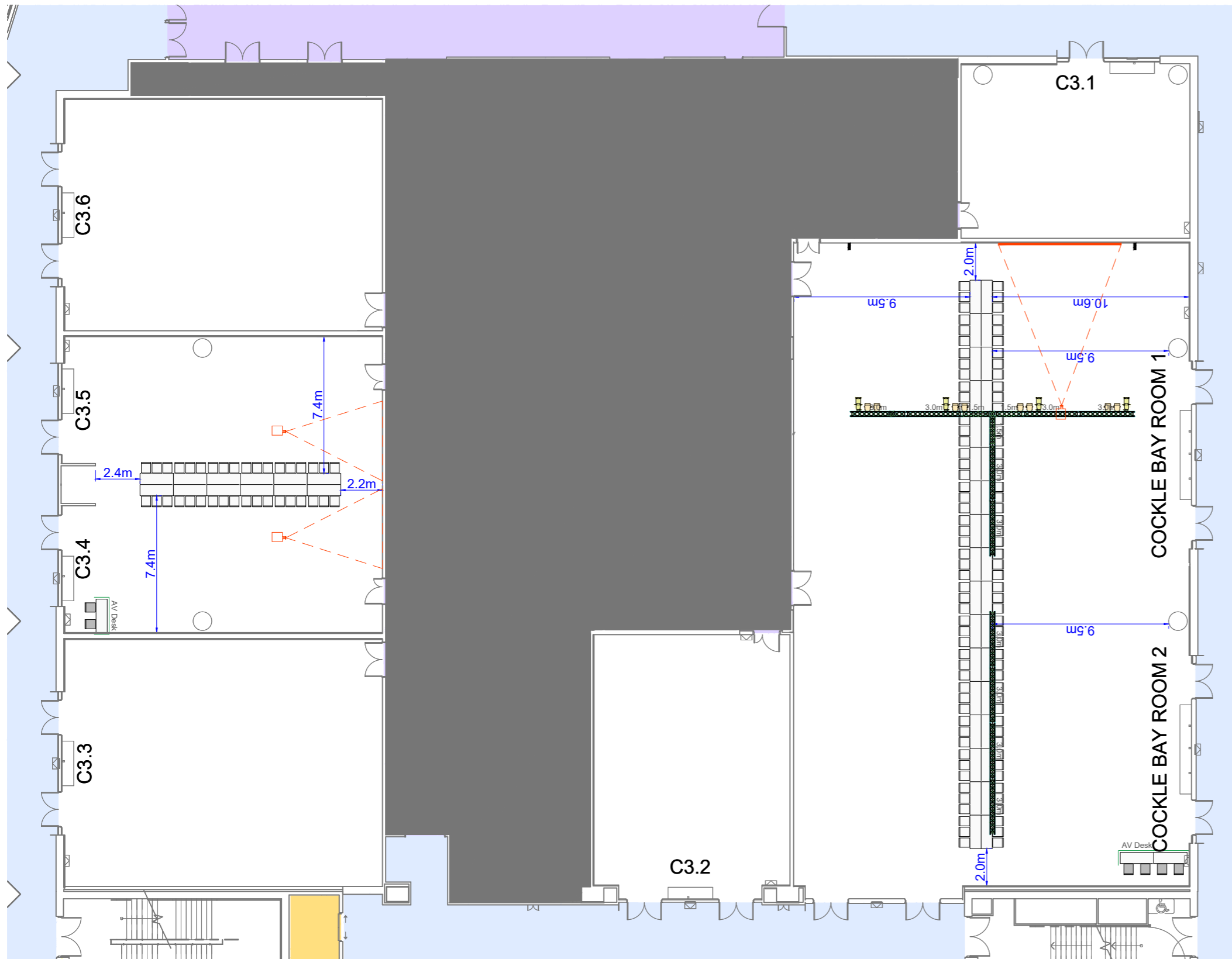

Axonometric cutaway view of Level 3 Convention Centre

ROOM NAME	BOARDROOM
COCKLE BAY ROOM	102
COCKLE BAY ROOM 1	48
COCKLE BAY ROOM 2	54
MEETING ROOM C3.1	30
MEETING ROOM C3.2	30
MEETING ROOM C3.3	42
MEETING ROOM C3.4	42
MEETING ROOM C3.5	42
MEETING ROOM C3.4 & C3.5	36
MEETING ROOM C3.6	42

* Standard capacity illustrated.

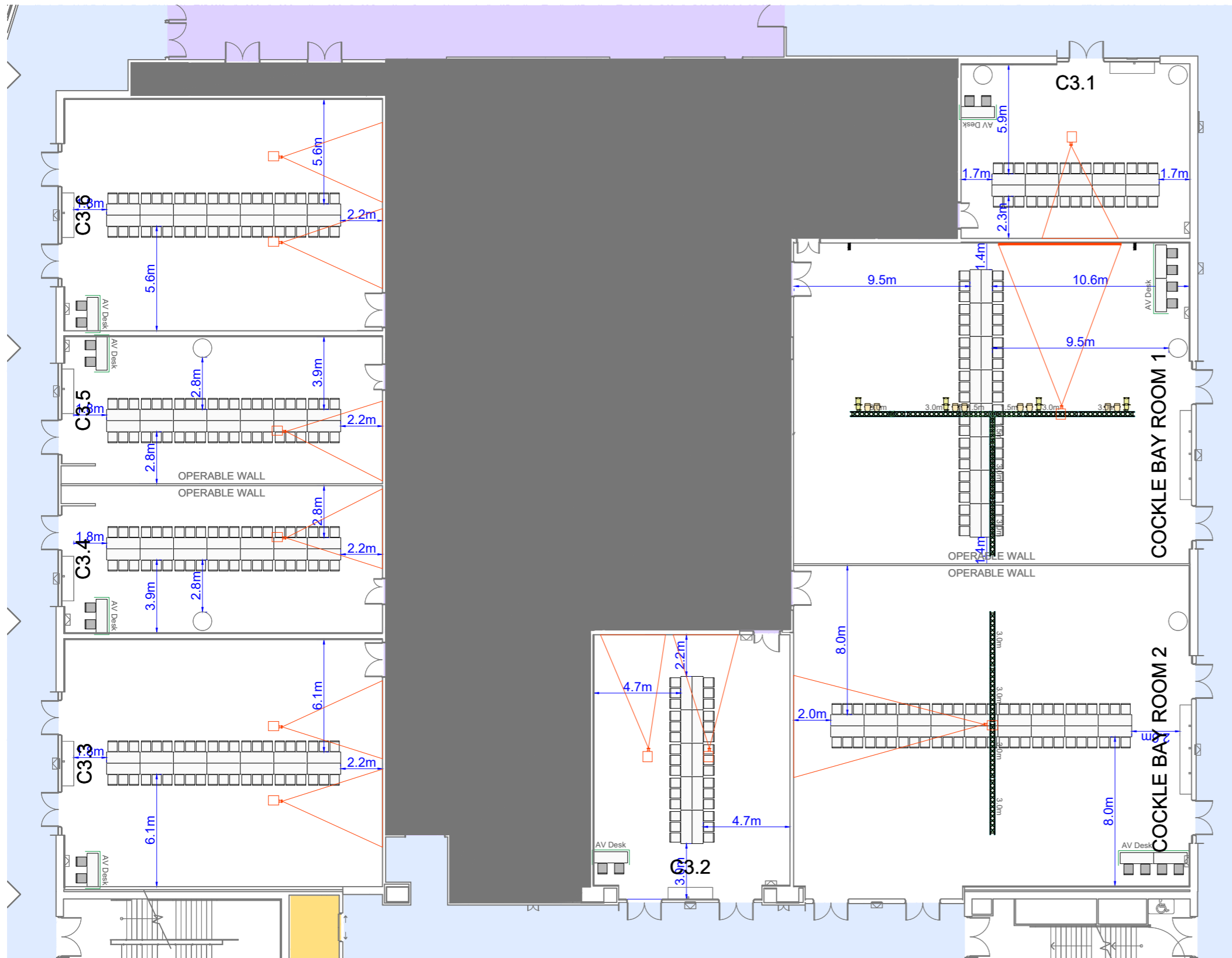

Axonometric cutaway view of Level 3 Convention Centre

ROOM NAME	BOARDROOM
COCKLE BAY ROOM	102
COCKLE BAY ROOM 1	48
COCKLE BAY ROOM 2	54
MEETING ROOM C3.1	30
MEETING ROOM C3.2	30
MEETING ROOM C3.3	42
MEETING ROOM C3.4	42
MEETING ROOM C3.5	42
MEETING ROOM C3.4 & C3.5	36
MEETING ROOM C3.6	42

* Standard capacity illustrated.

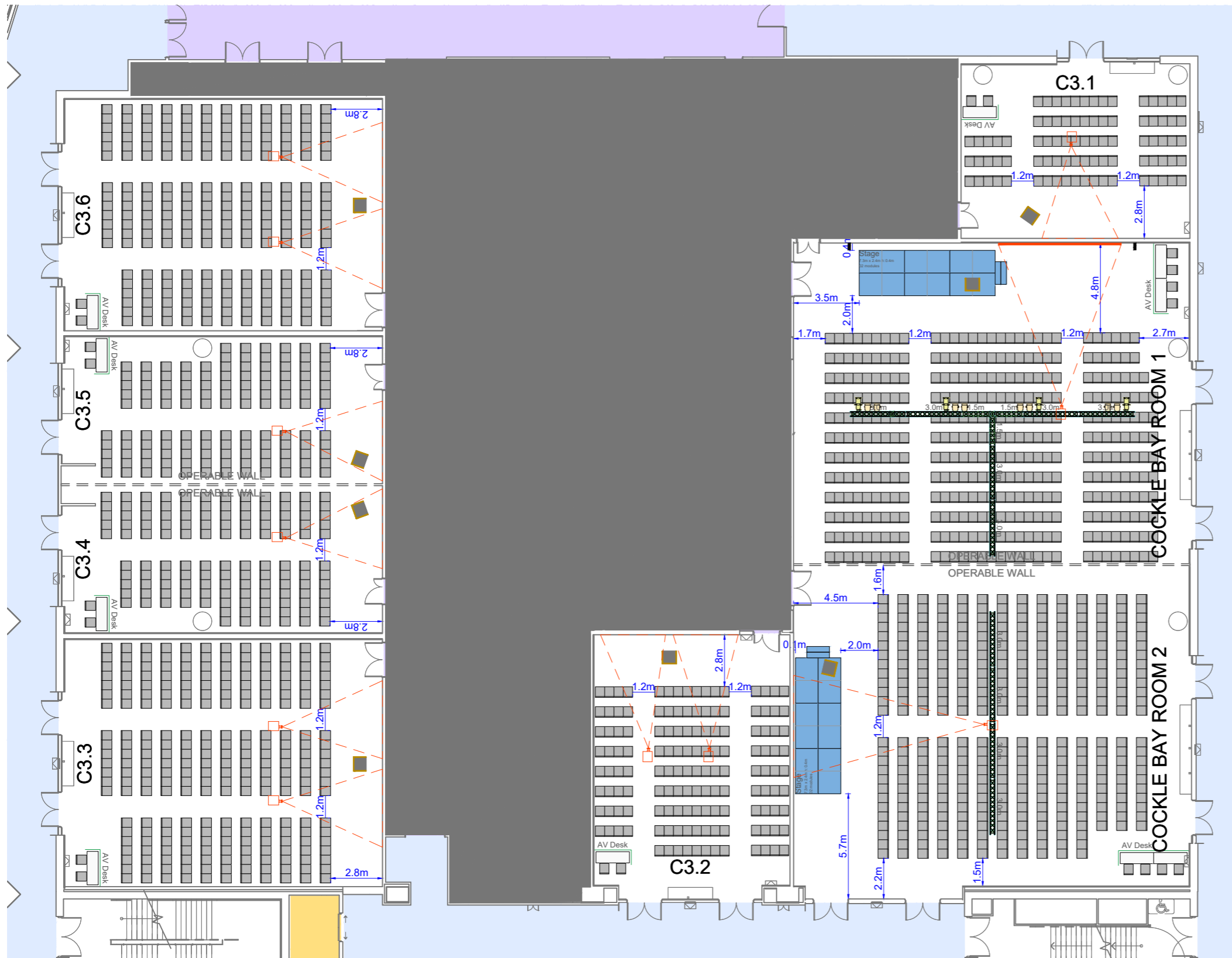

Axonometric cutaway view of Level 3 Convention Centre

ROOM NAME	THEATRE
COCKLE BAY ROOM	790
COCKLE BAY ROOM 1	367
COCKLE BAY ROOM 2	355
MEETING ROOM C3.1	85
MEETING ROOM C3.2	140
MEETING ROOM C3.3	245
MEETING ROOM C3.4	127
MEETING ROOM C3.5	127
MEETING ROOM C3.4 & C3.5	260
MEETING ROOM C3.6	222

* Standard Capacity illustrated. Higher capacities can be achieved with less staging and AV services and reduced furniture spacing. Please consider your event requirements when viewing capacities

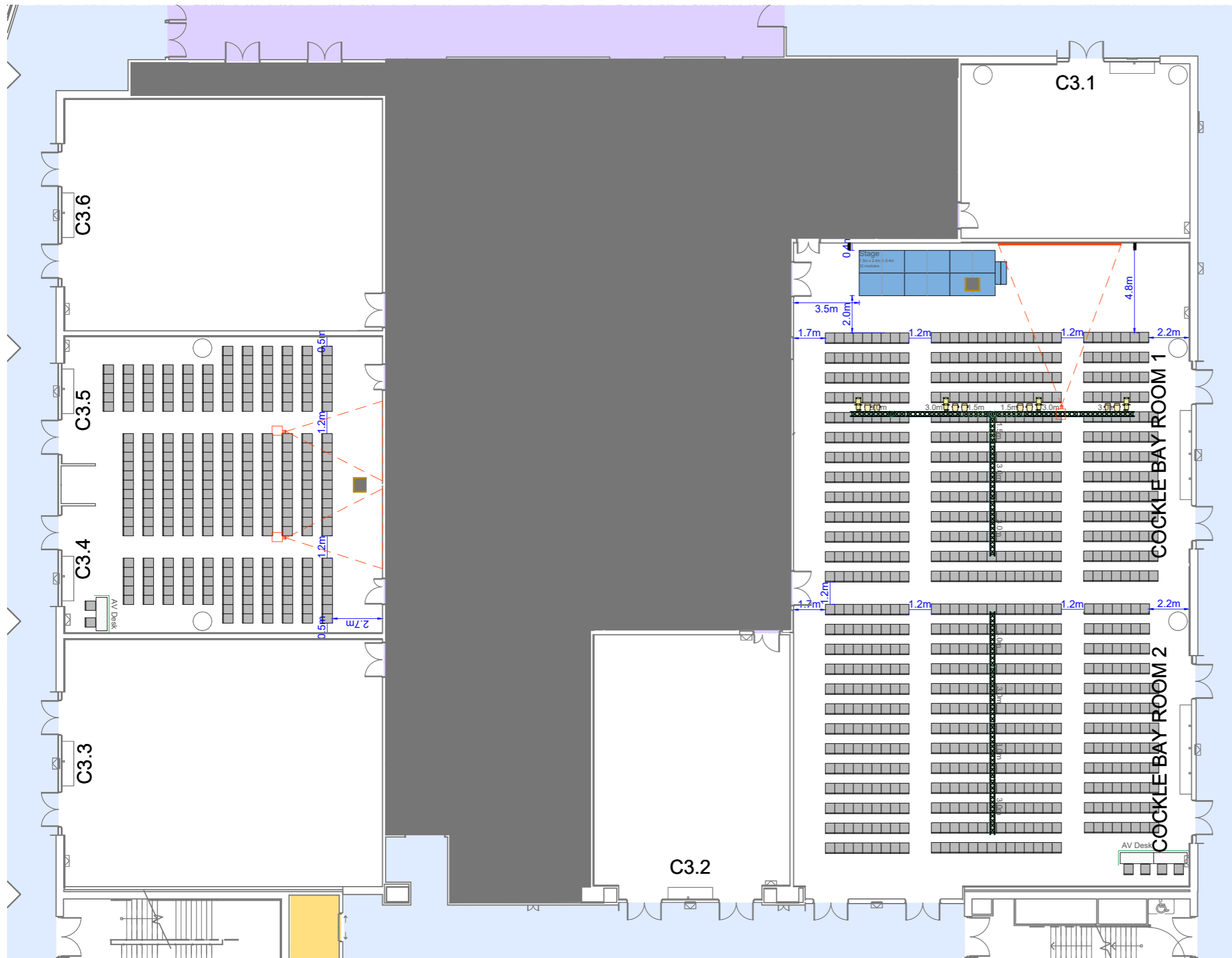

Axonometric cutaway view of Level 3 Convention Centre

ROOM NAME	THEATRE
COCKLE BAY ROOM	790
COCKLE BAY ROOM 1	367
COCKLE BAY ROOM 2	355
MEETING ROOM C3.1	85
MEETING ROOM C3.2	140
MEETING ROOM C3.3	245
MEETING ROOM C3.4	127
MEETING ROOM C3.5	127
MEETING ROOM C3.4 & C3.5	260
MEETING ROOM C3.6	222

* Standard Capacity illustrated. Higher capacities can be achieved with less staging and AV services and reduced furniture spacing. Please consider your event requirements when viewing capacities

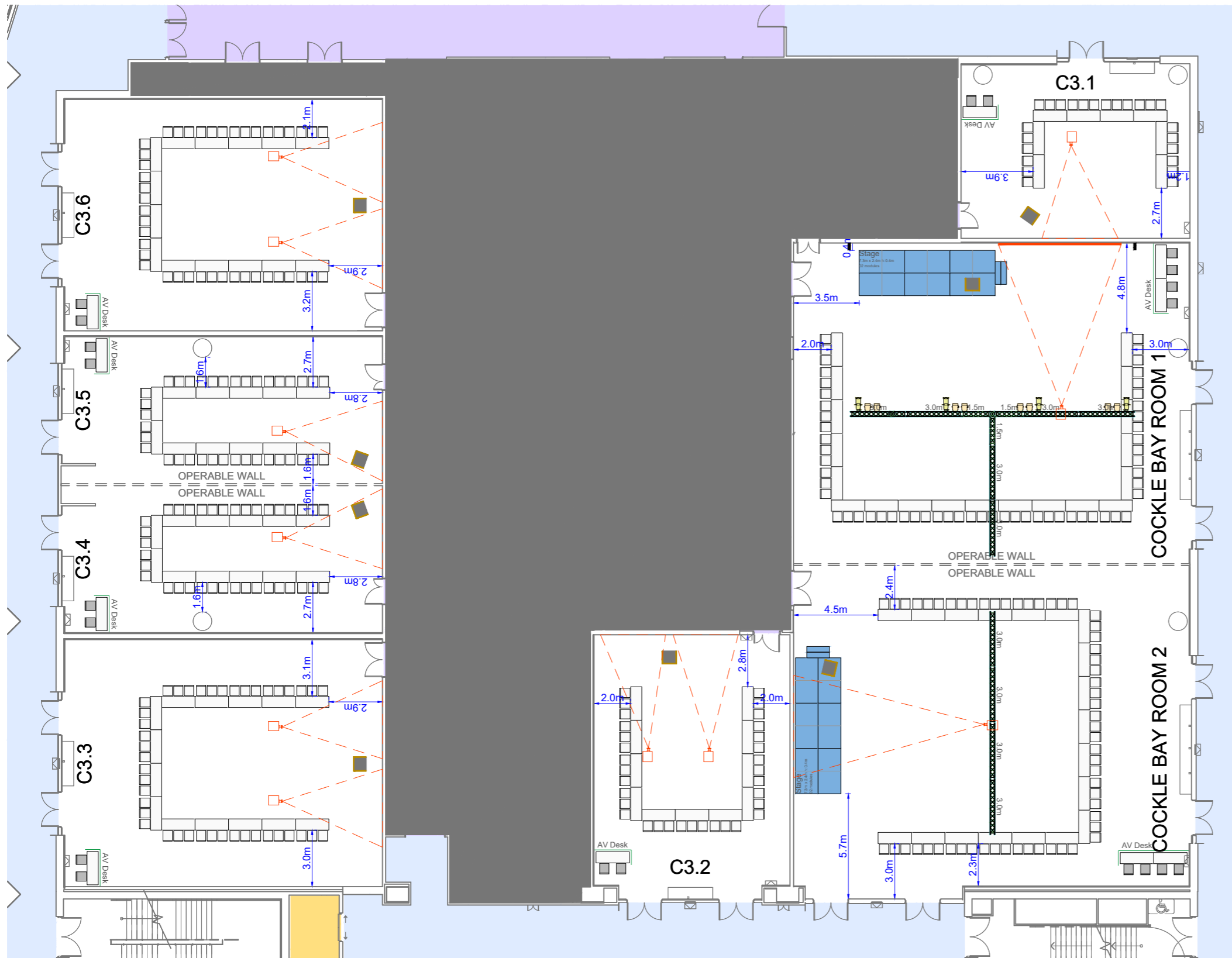

Axonometric cutaway view of Level 3 Convention Centre

ROOM NAME	U SHAPE
COCKLE BAY ROOM	108
COCKLE BAY ROOM 1	57
COCKLE BAY ROOM 2	57
MEETING ROOM C3.1	24
MEETING ROOM C3.2	33
MEETING ROOM C3.3	42
MEETING ROOM C3.4	36
MEETING ROOM C3.5	36
MEETING ROOM C3.4 & C3.5	48
MEETING ROOM C3.6	42

* Standard Capacity illustrated.

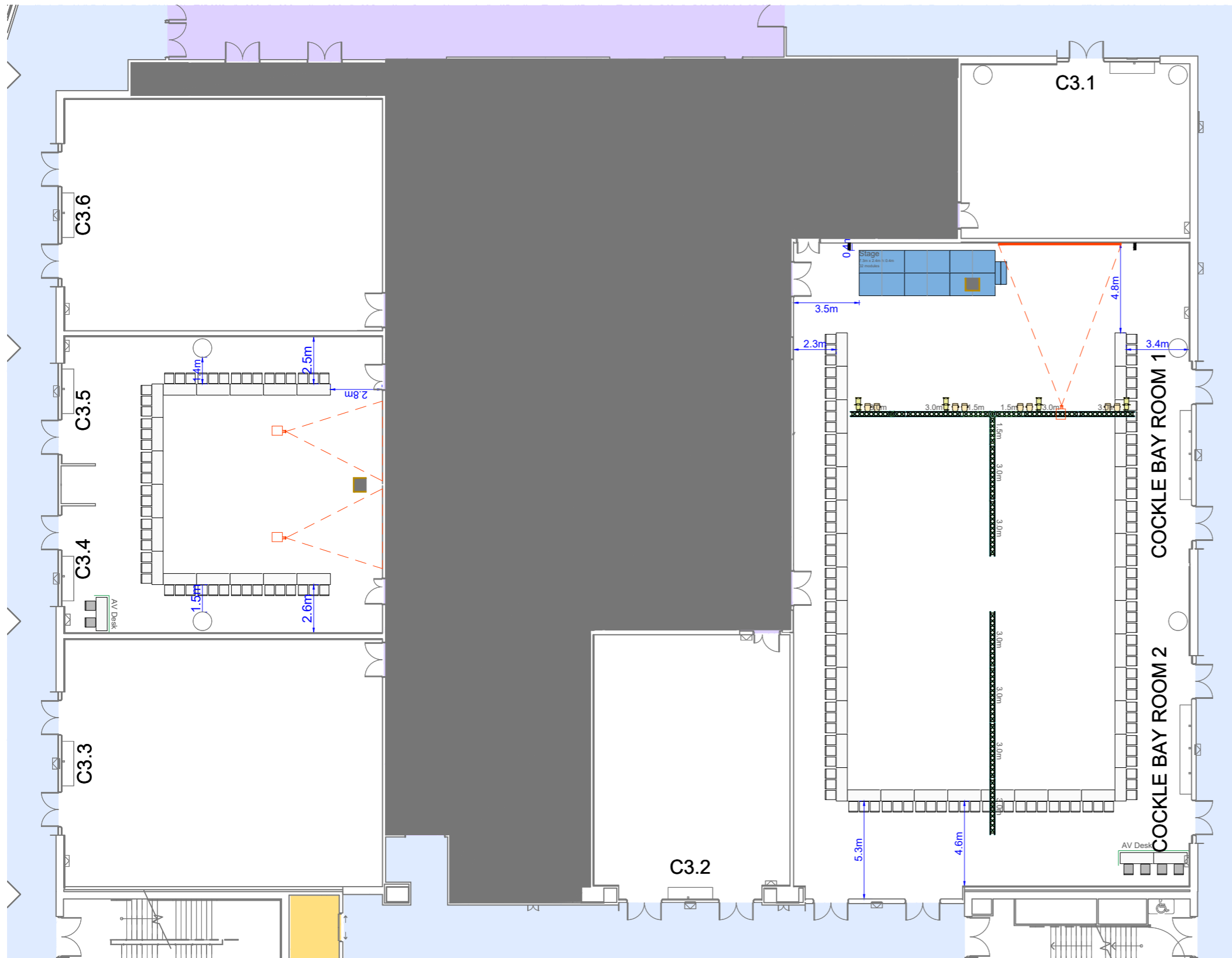

Axonometric cutaway view of Level 3 Convention Centre

ROOM NAME	U SHAPE
COCKLE BAY ROOM	108
COCKLE BAY ROOM 1	57
COCKLE BAY ROOM 2	57
MEETING ROOM C3.1	24
MEETING ROOM C3.2	33
MEETING ROOM C3.3	42
MEETING ROOM C3.4	36
MEETING ROOM C3.5	36
MEETING ROOM C3.4 & C3.5	48
MEETING ROOM C3.6	42

* Standard Capacity illustrated.

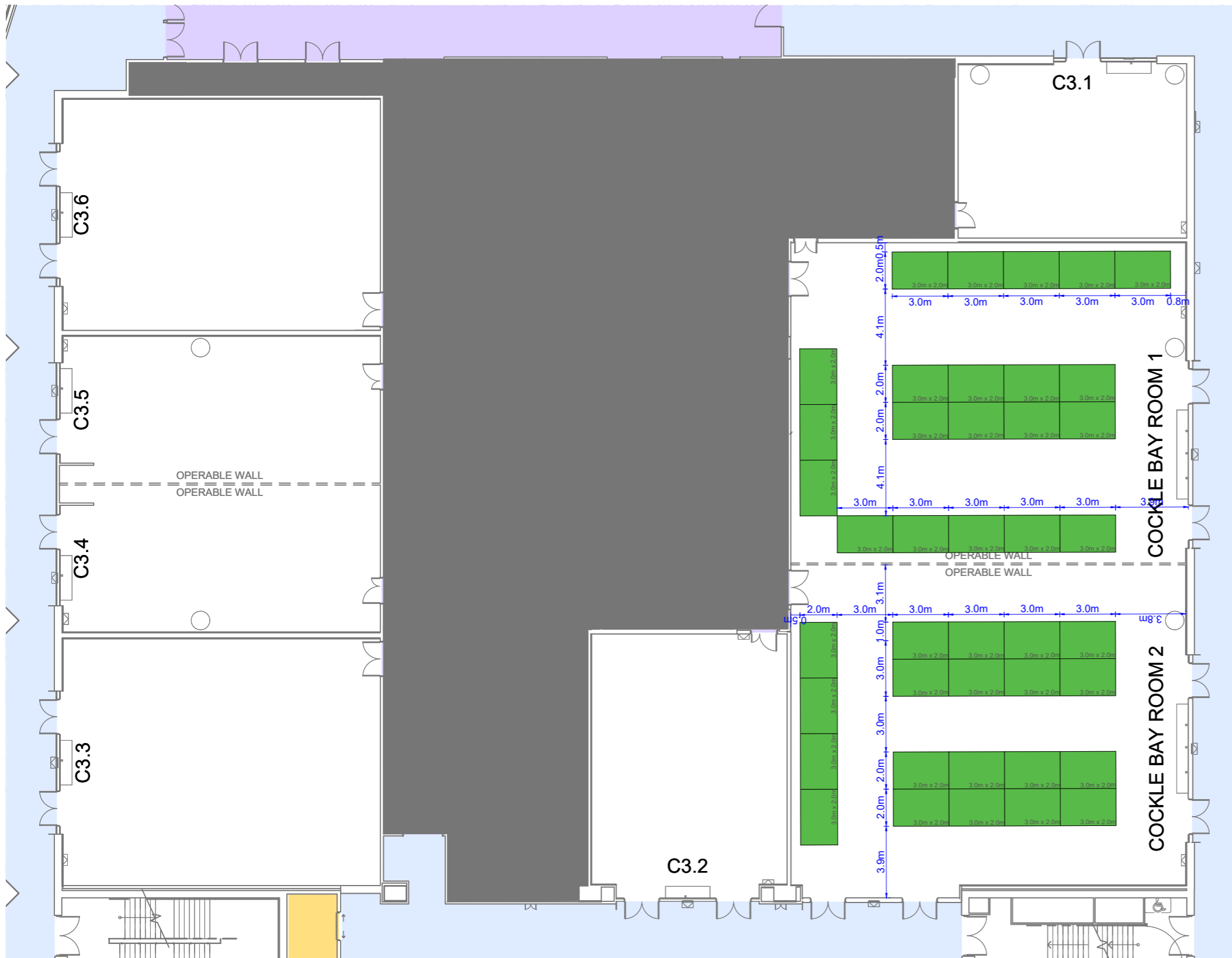

Axonometric cutaway view of Level 3 Convention Centre

ROOM NAME	EXHIBITION	
	3m x 3m	3m x 2m
COCKLE BAY ROOM	36	45
COCKLE BAY ROOM 1	16 (3x3) 5 (3x2)	21
COCKLE BAY ROOM 2	16 (3x3) 3 (3x2)	20

* Maximum Capacity illustrated.

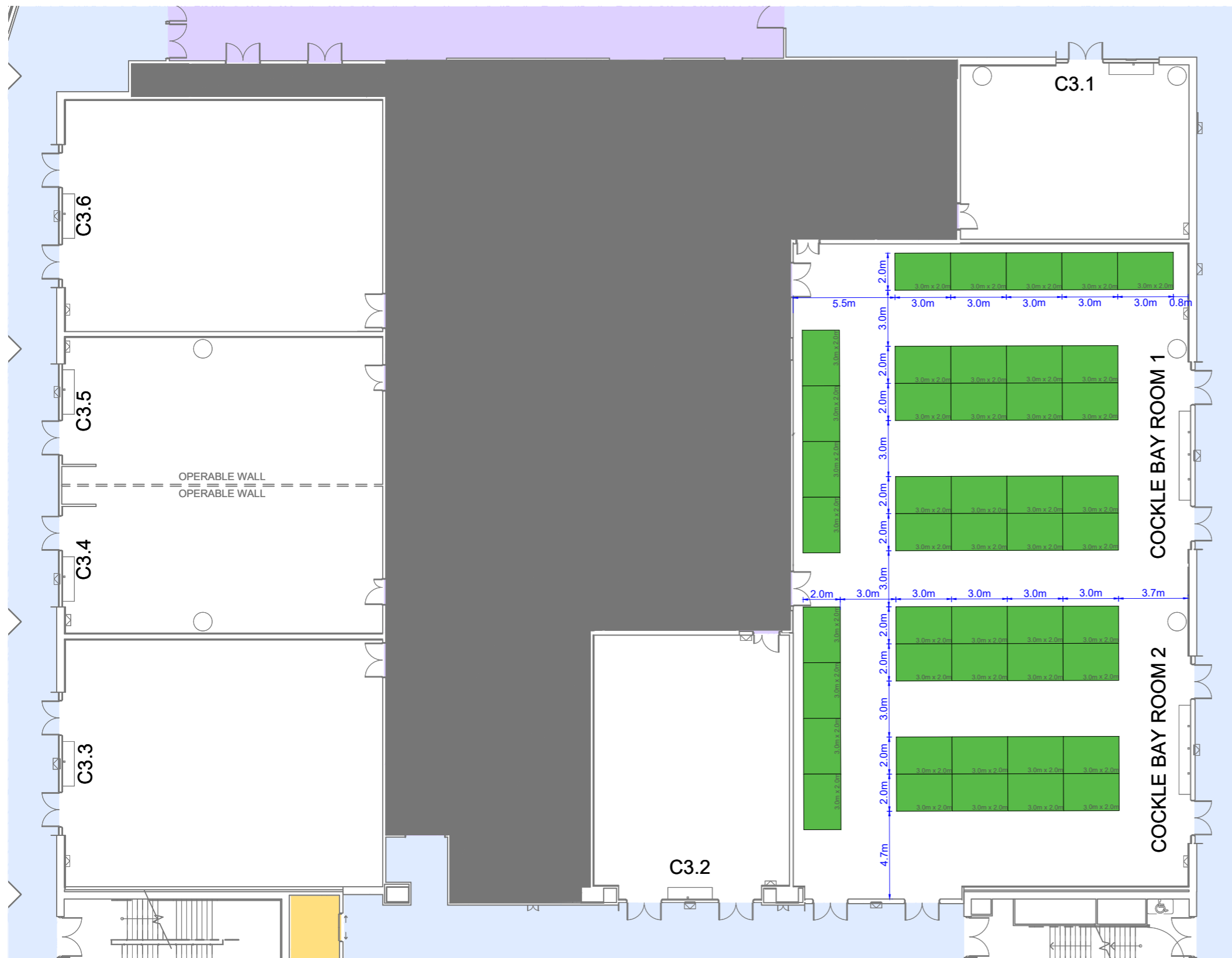

Axonometric cutaway view of Level 3 Convention Centre

ROOM NAME	EXHIBITION	
	3m x 3m	3m x 2m
COCKLE BAY ROOM	36	45
COCKLE BAY ROOM 1	16 (3x3) 5 (3x2)	21
COCKLE BAY ROOM 2	16 (3x3) 3 (3x2)	20

* Maximum Capacity illustrated.

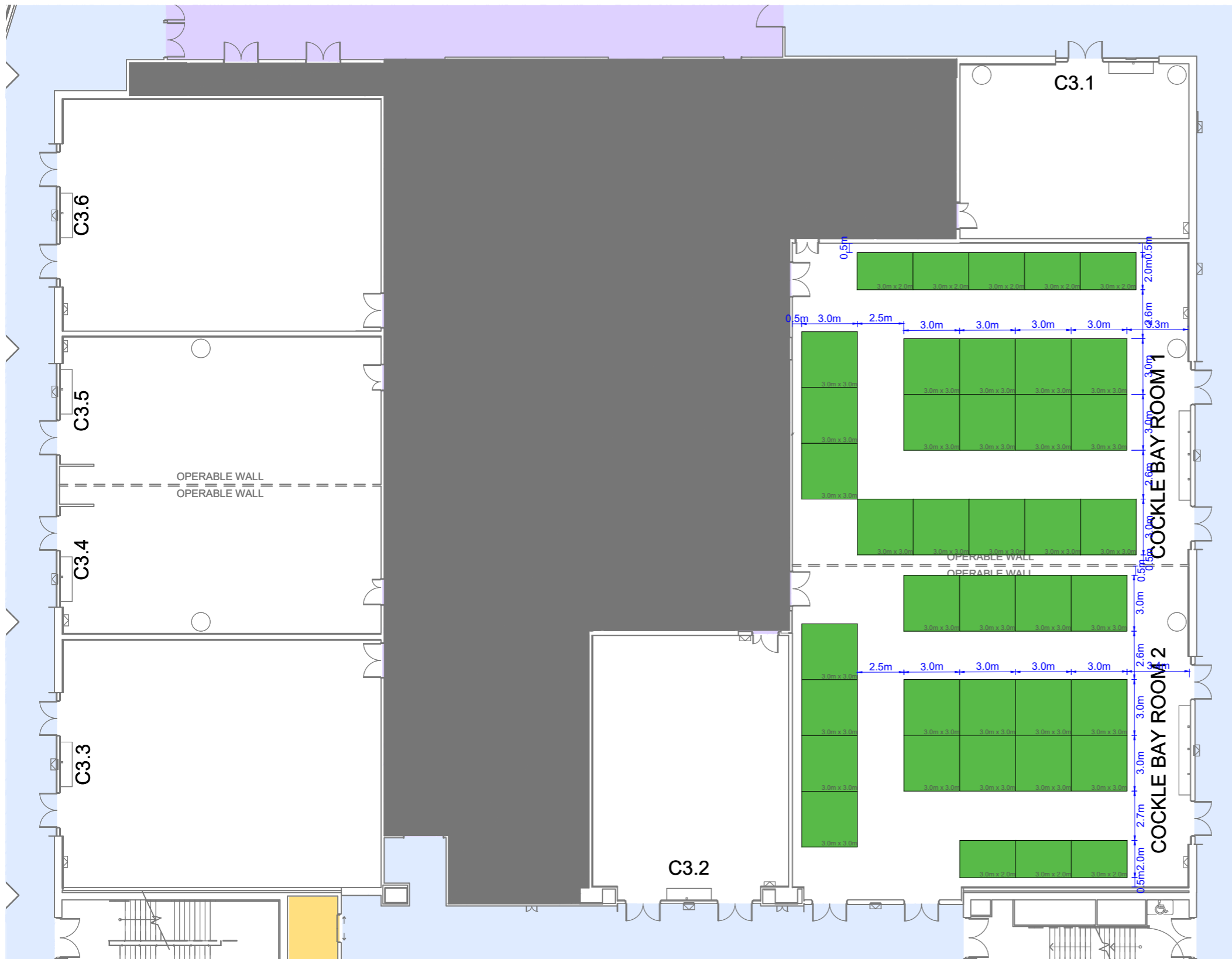

Axonometric cutaway view of Level 3 Convention Centre

ROOM NAME	EXHIBITION	
	3m x 3m	3m x 2m
COCKLE BAY ROOM	36	45
COCKLE BAY ROOM 1	16 (3x3) 5 (3x2)	21
COCKLE BAY ROOM 2	16 (3x3) 3 (3x2)	20

* Maximum Capacity illustrated.

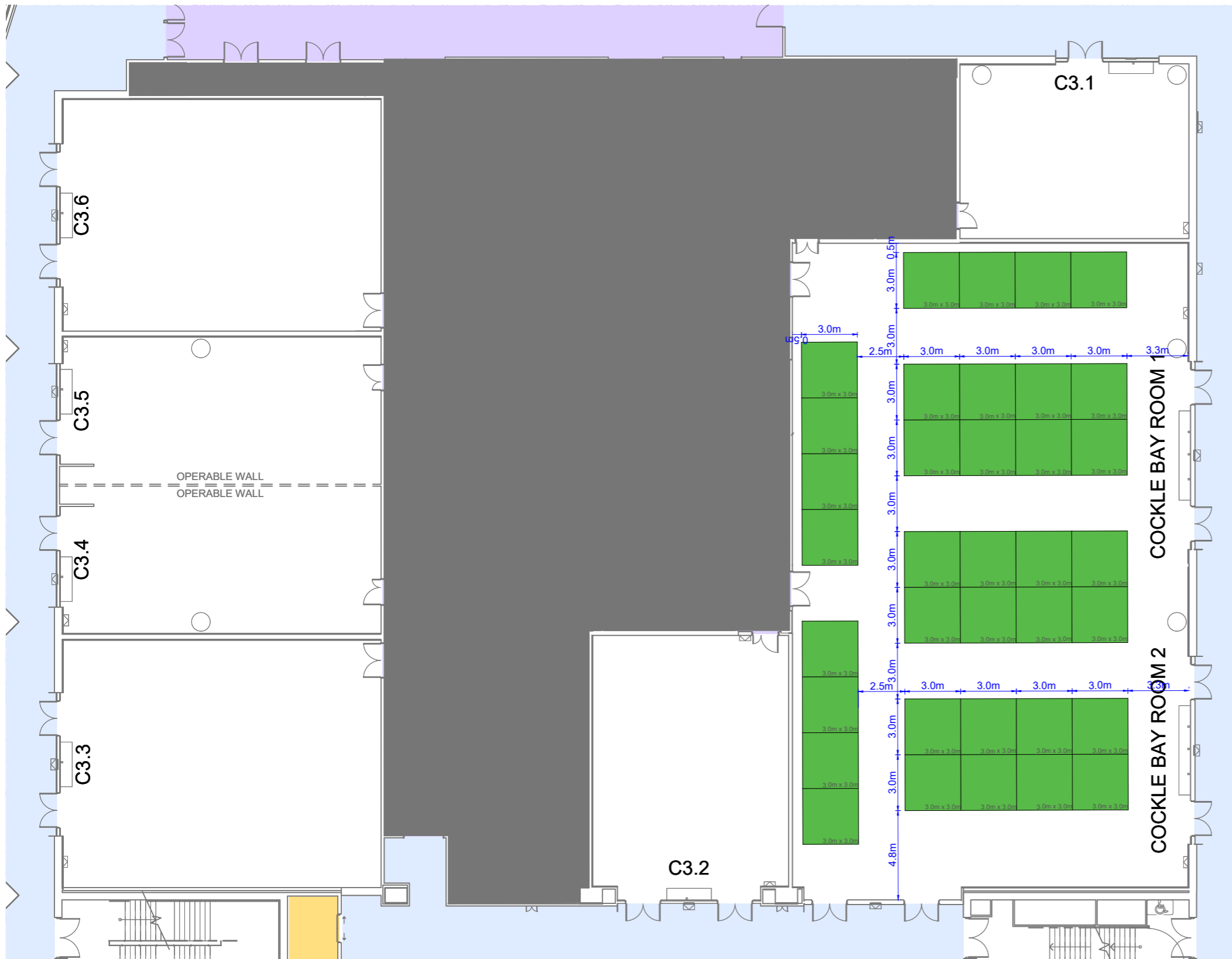

Axonometric cutaway view of Level 3 Convention Centre

ROOM NAME	EXHIBITION	
	3m x 3m	3m x 2m
COCKLE BAY ROOM	36	45
COCKLE BAY ROOM 1	16 (3x3) 5 (3x2)	21
COCKLE BAY ROOM 2	16 (3x3) 3 (3x2)	20

* Maximum Capacity illustrated.

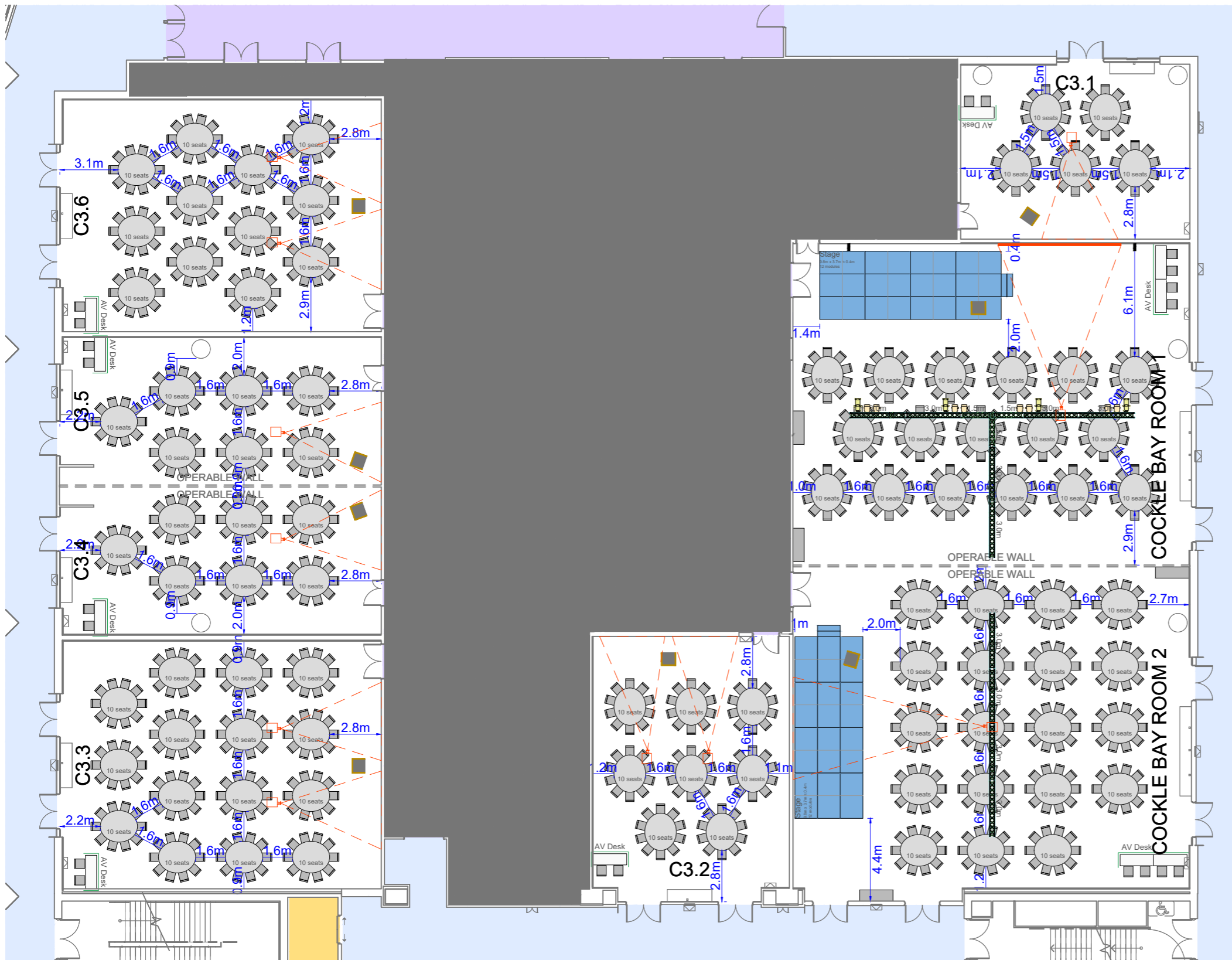

Axonometric cutaway view of Level 3 Convention Centre

ROOM NAME	BANQUET
COCKLE BAY ROOM	470
COCKLE BAY ROOM 1	170
COCKLE BAY ROOM 2	190
MEETING ROOM C3.1	50
MEETING ROOM C3.2	80
MEETING ROOM C3.3	150
MEETING ROOM C3.4	70
MEETING ROOM C3.5	70
MEETING ROOM C3.4 & C3.5	140
MEETING ROOM C3.6	120

* Standard capacity illustrated. Higher capacities can be achieved with less staging and AV services and reduced furniture spacing. Please consider your event requirements when viewing capacities.

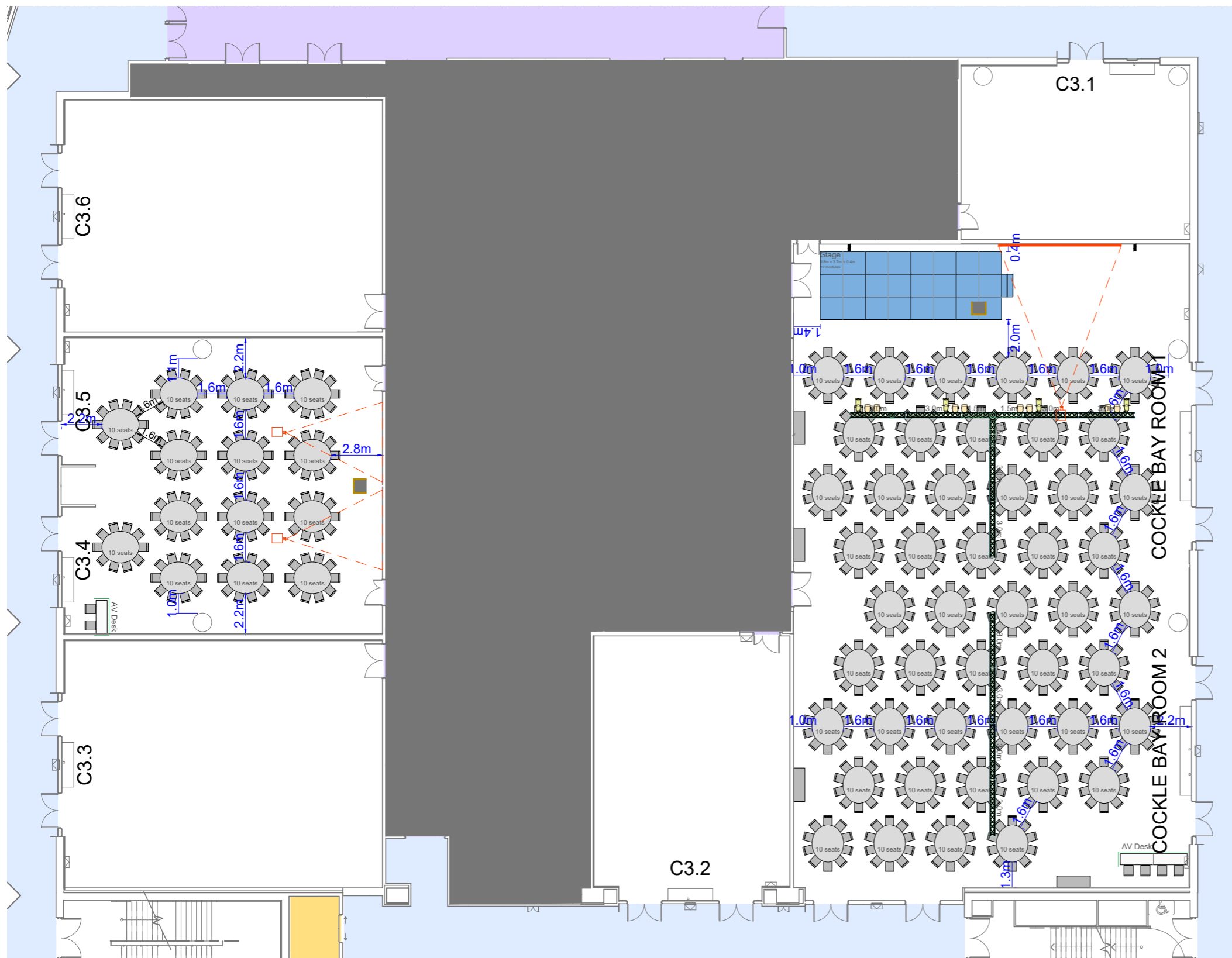

Axonometric cutaway view of Level 3 Convention Centre

ROOM NAME	BANQUET
COCKLE BAY ROOM	470
COCKLE BAY ROOM 1	170
COCKLE BAY ROOM 2	190
MEETING ROOM C3.1	50
MEETING ROOM C3.2	80
MEETING ROOM C3.3	150
MEETING ROOM C3.4	70
MEETING ROOM C3.5	70
MEETING ROOM C3.4 & C3.5	140
MEETING ROOM C3.6	120

* Standard capacity illustrated. Higher capacities can be achieved with less staging and AV services and reduced furniture spacing. Please consider your event requirements when viewing capacities.

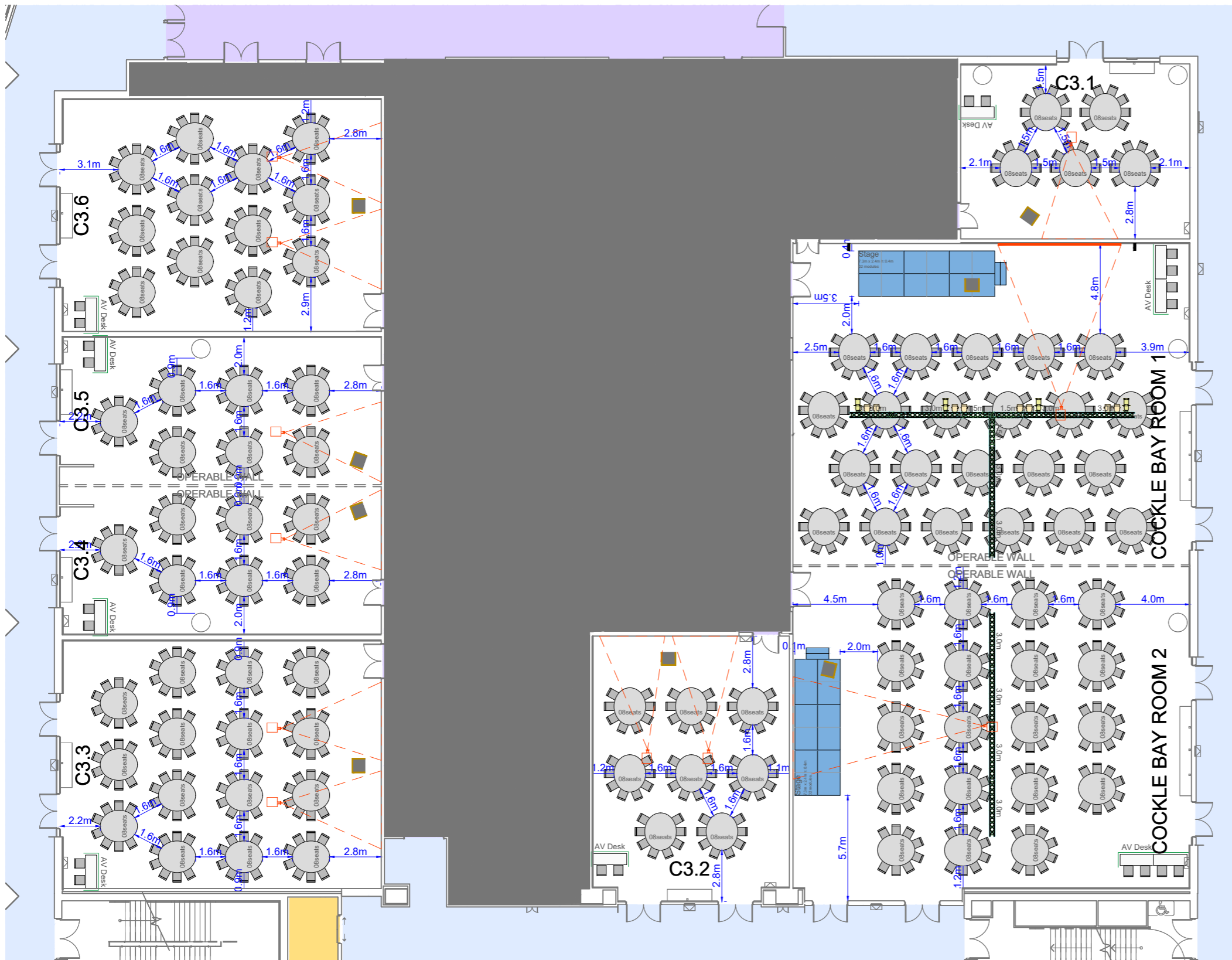

Axonometric cutaway view of Level 3 Convention Centre

ROOM NAME	CABARET
COCKLE BAY ROOM	376
COCKLE BAY ROOM 1	176
COCKLE BAY ROOM 2	152
MEETING ROOM C3.1	40
MEETING ROOM C3.2	64
MEETING ROOM C3.3	120
MEETING ROOM C3.4	56
MEETING ROOM C3.5	56
MEETING ROOM C3.4 & C3.5	112
MEETING ROOM C3.6	96

* Standard capacity illustrated. Higher capacities can be achieved with less staging and AV services and reduced furniture spacing. Please consider your event requirements when viewing capacities.

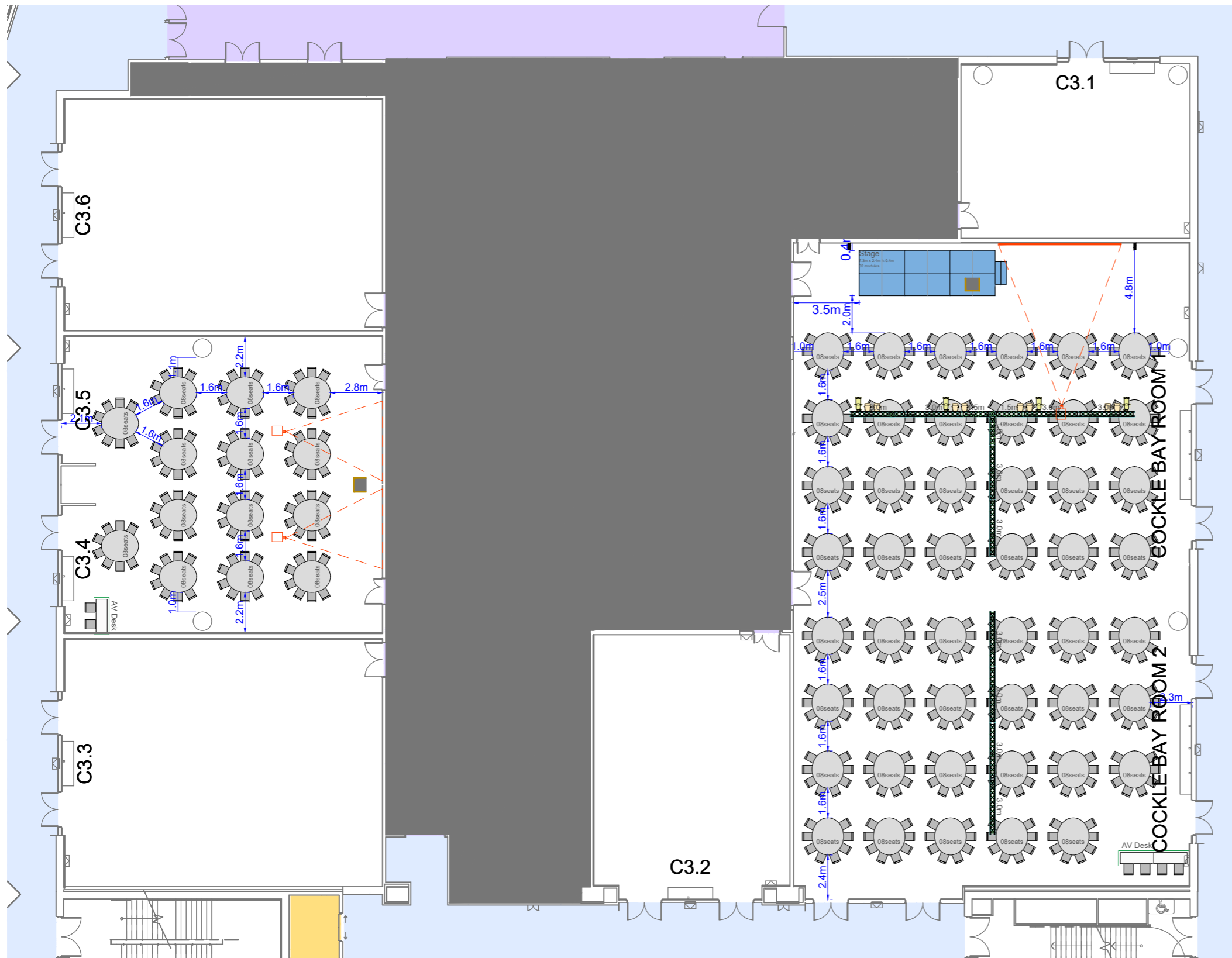

Axonometric cutaway view of Level 3 Convention Centre

ROOM NAME	CABARET
COCKLE BAY ROOM	376
COCKLE BAY ROOM 1	176
COCKLE BAY ROOM 2	152
MEETING ROOM C3.1	40
MEETING ROOM C3.2	64
MEETING ROOM C3.3	120
MEETING ROOM C3.4	56
MEETING ROOM C3.5	56
MEETING ROOM C3.4 & C3.5	112
MEETING ROOM C3.6	96

* Standard capacity illustrated. Higher capacities can be achieved with less staging and AV services and reduced furniture spacing. Please consider your event requirements when viewing capacities.

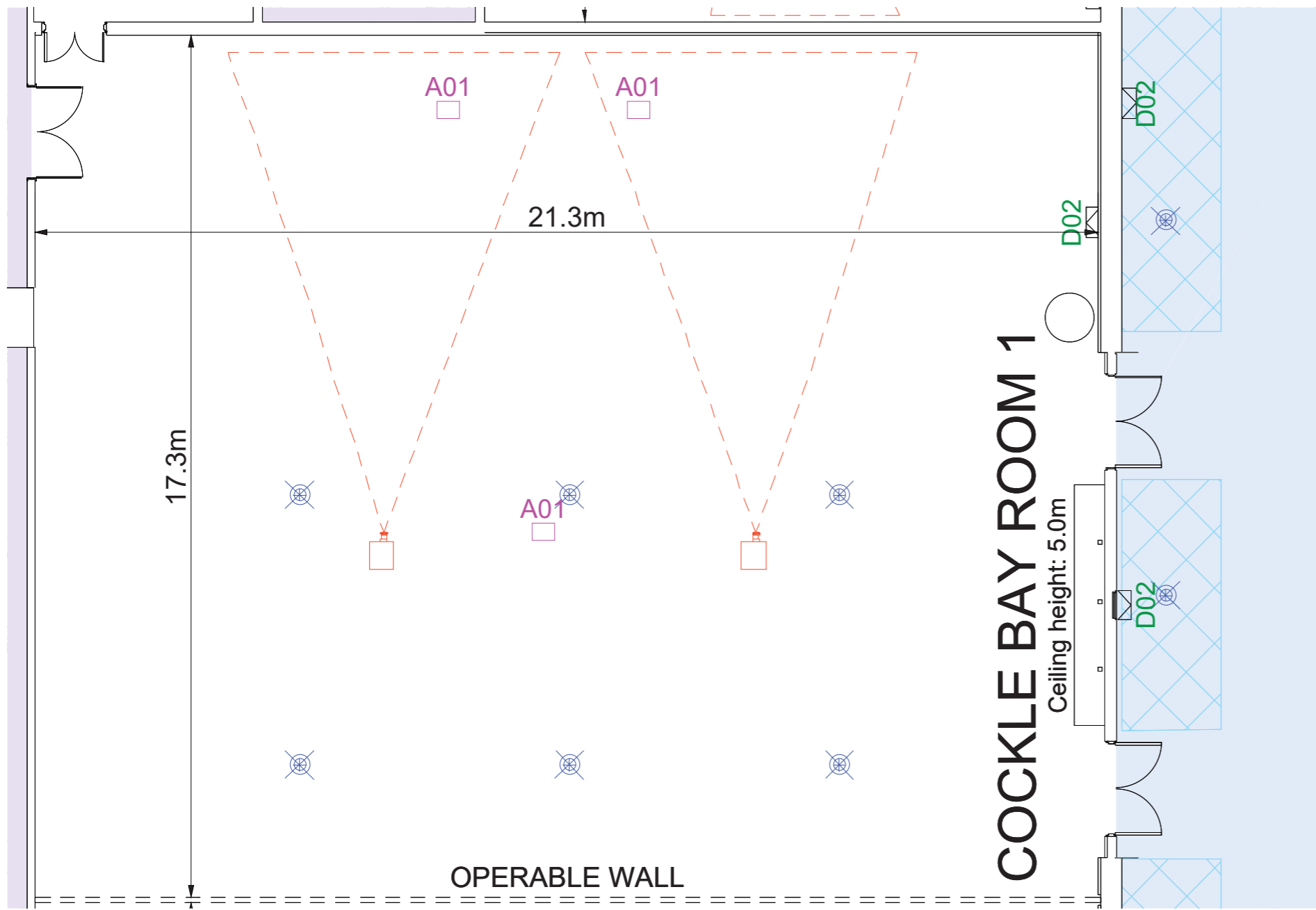

Level 3 Meeting room key plan

LEGEND

- Public Space Build Zone
- Circulation back of house
- Circulation front of house
- Floor Box Type A01
6 x SGPO
2 x SINGLE DATA
- Floor Box Type A07
2 x 15A SGPO
1 x 32A 3PH
2 x SINGLE DATA
- Floor Box Type A09
2 x SGPO
1 x 20A SGPO
2 x SINGLE DATA
- Floor Box Type A10
2 x SGPO
1 x 32A 3PH
2 x SINGLE DATA
- Service Cupboard 02
2 x DGPO
1 x 32A 3PH
4 x SINGLE DATA
1 x 6C SMOF
- Service Cupboard 04
2 x 15A SGPO
1 x 32A 3PH
2 x SINGLE DATA
- Service Cupboard 05
1 x DGPO
1 x 32A 3PH
2 x SINGLE DATA
- Service Cupboard 06
1 x DGPO
1 x 20A SGPO
2 x SINGLE DATA
- Rigging Point 1.0T
- Projector

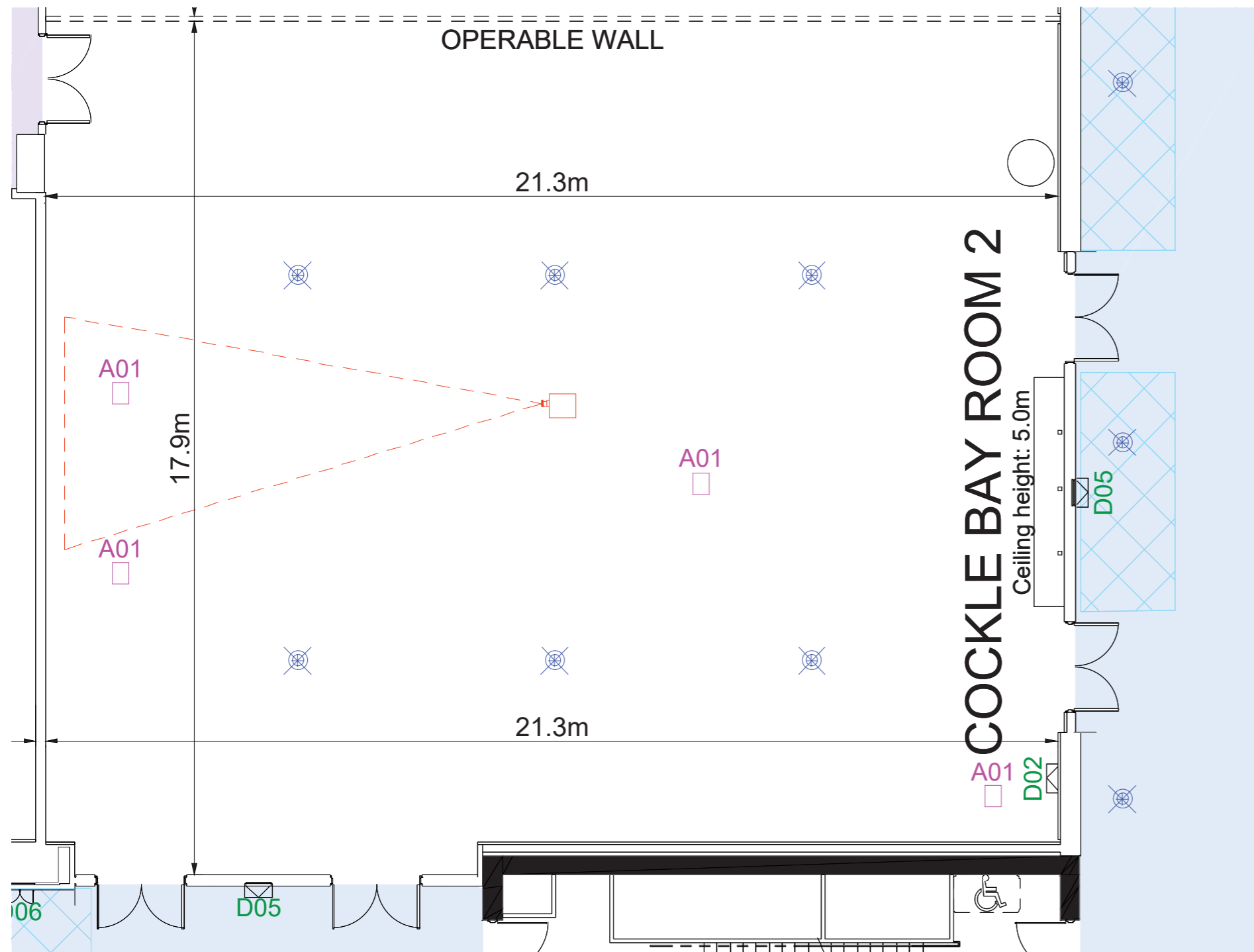

Level 3 Meeting room key plan

LEGEND

- Public Space Build Zone
- Circulation back of house
- Circulation front of house
- A01** Floor Box Type A01
6 x SGPO
2 x SINGLE DATA
- A07** Floor Box Type A07
2 x 15A SGPO
1 x 32A 3PH
2 x SINGLE DATA
- A09** Floor Box Type A09
2 x SGPO
1 x 20A SGPO
2 x SINGLE DATA
- A10** Floor Box Type A10
2 x SGPO
1 x 32A 3PH
2 x SINGLE DATA
- D02** Service Cupboard 02
2 x DGPO
1 x 32A 3PH
4 x SINGLE DATA
1 x 6C SMOF
- D04** Service Cupboard 04
2 x 15A SGPO
1 x 32A 3PH
2 x SINGLE DATA
- D05** Service Cupboard 05
1 x DGPO
1 x 32A 3PH
2 x SINGLE DATA
- D06** Service Cupboard 06
1 x DGPO
1 x 20A SGPO
2 x SINGLE DATA
- Rigging Point 1.0T
- Projector

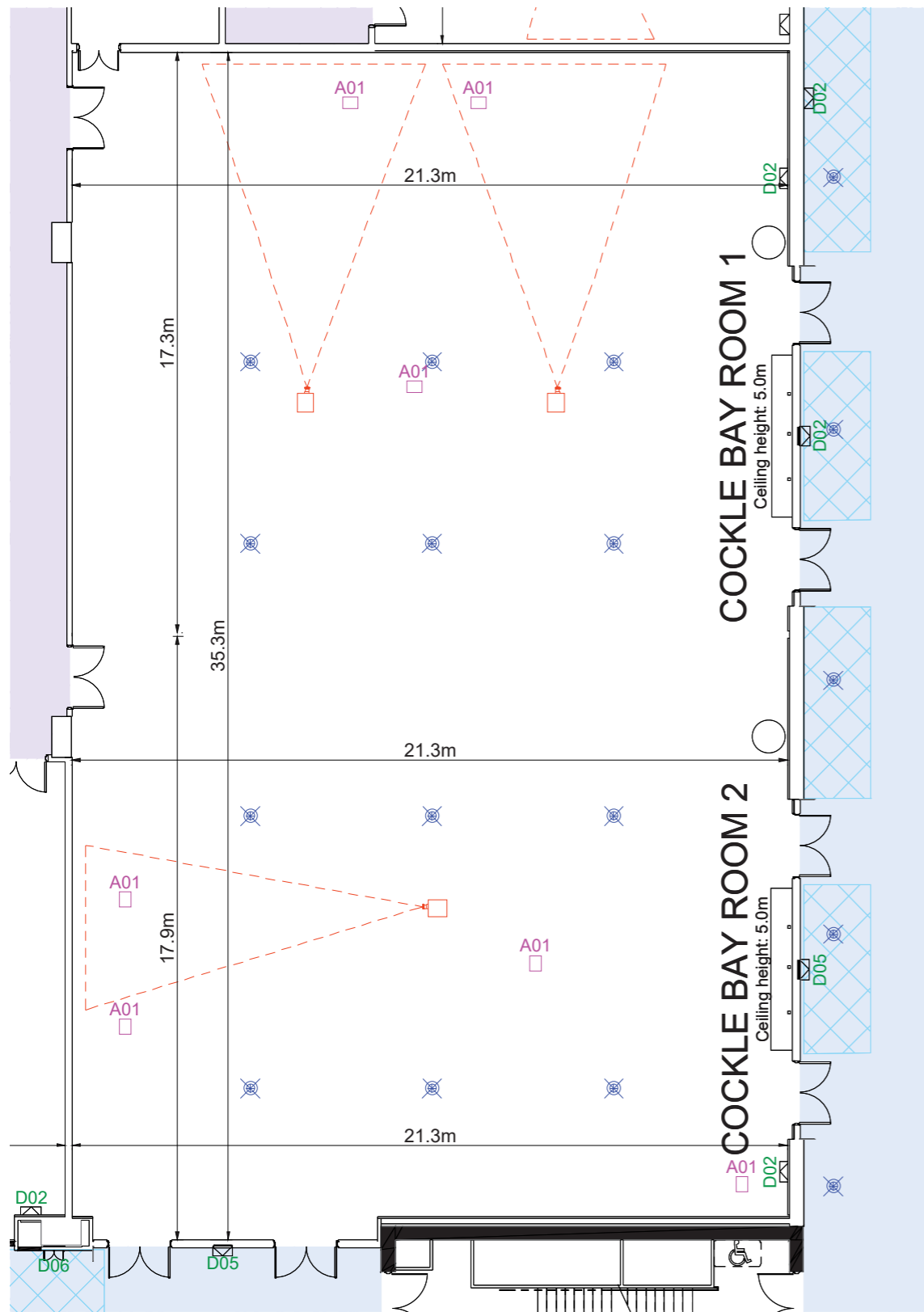

Level 3 Meeting room key plan





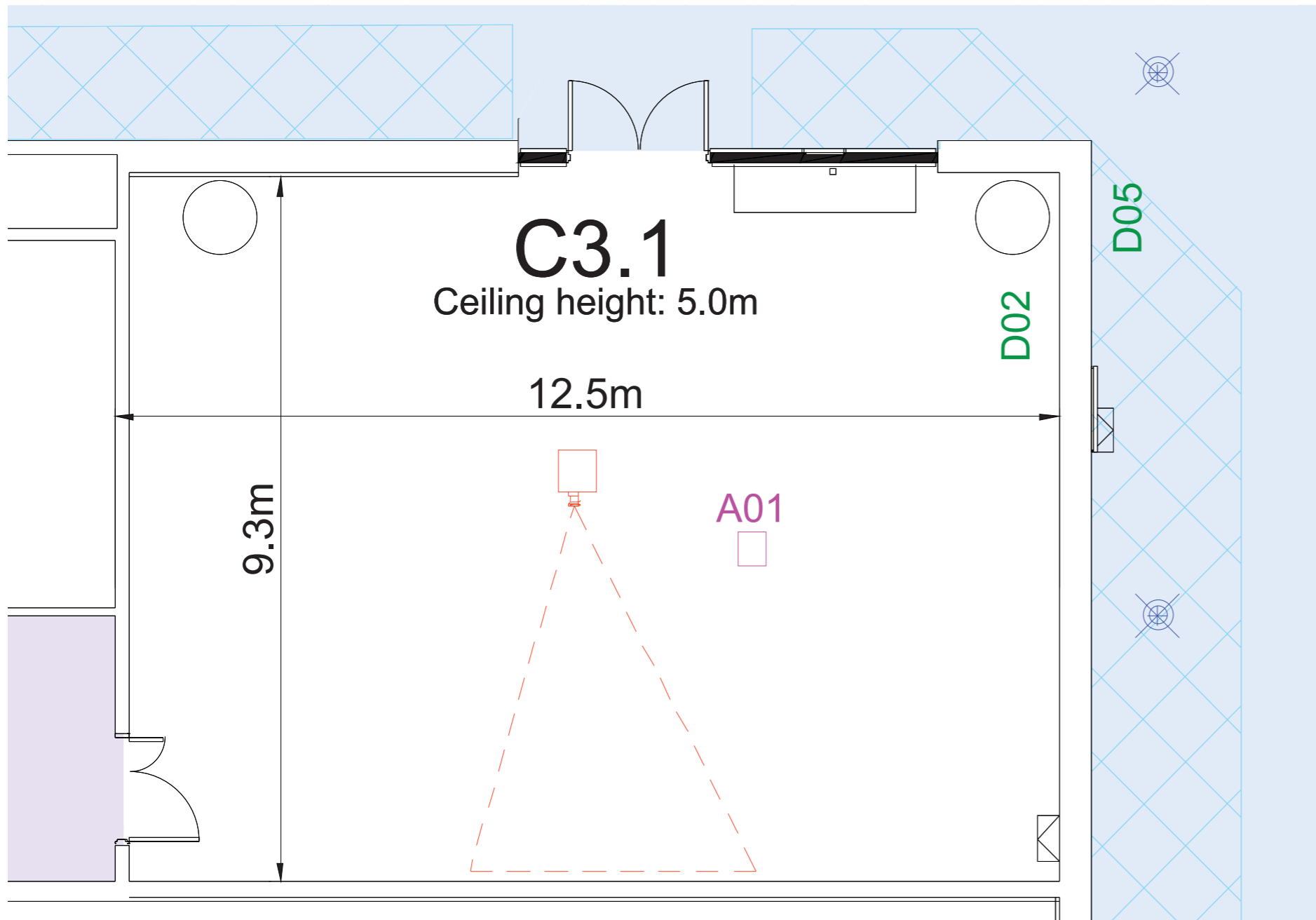







LEGEND

- | | | | |
|--|---|--|----------------------------|
| | Public Space Build Zone | | Circulation back of house |
| | A01 Floor Box Type A01
6 x SGPO
2 x SINGLE DATA | | Circulation front of house |
| | A07 Floor Box Type A07
2 x 15A SGPO
1 x 32A 3PH
2 x SINGLE DATA | | |
| | A09 Floor Box Type A09
2 x SGPO
1 x 20A SGPO
2 x SINGLE DATA | | |
| | A10 Floor Box Type A10
2 x SGPO
1 x 32A 3PH
2 x SINGLE DATA | | |
| | D02 Service Cupboard 02
2 x DGPO
1 x 32A 3PH
4 x SINGLE DATA
1 x 6C SMOF | | |
| | D04 Service Cupboard 04
2 x 15A SGPO
1 x 32A 3PH
2 x SINGLE DATA | | |
| | D05 Service Cupboard 05
1 x DGPO
1 x 32A 3PH
2 x SINGLE DATA | | |
| | D06 Service Cupboard 06
1 x DGPO
1 x 20A SGPO
2 x SINGLE DATA | | |
| | Rigging Point 1.0T | | |
| | Projector | | |



Level 3 Meeting room key plan

LEGEND

-  Public Space Build Zone
-  Circulation back of house
-  Circulation front of house
-  **A01** Floor Box Type A01
6 x SGPO
2 x SINGLE DATA
-  **A07** Floor Box Type A07
2 x 15A SGPO
1 x 32A 3PH
2 x SINGLE DATA
-  **A09** Floor Box Type A09
2 x SGPO
1 x 20A SGPO
2 x SINGLE DATA
-  **A10** Floor Box Type A10
2 x SGPO
1 x 32A 3PH
2 x SINGLE DATA
-  **D02** Service Cupboard 02
2 x DGPO
1 x 32A 3PH
4 x SINGLE DATA
1 x 6C SMOF
-  **D04** Service Cupboard 04
2 x 15A SGPO
1 x 32A 3PH
2 x SINGLE DATA
-  **D05** Service Cupboard 05
1 x DGPO
1 x 32A 3PH
2 x SINGLE DATA
-  **D06** Service Cupboard 06
1 x DGPO
1 x 20A SGPO
2 x SINGLE DATA
-  Rigging Point 1.0T
-  Projector

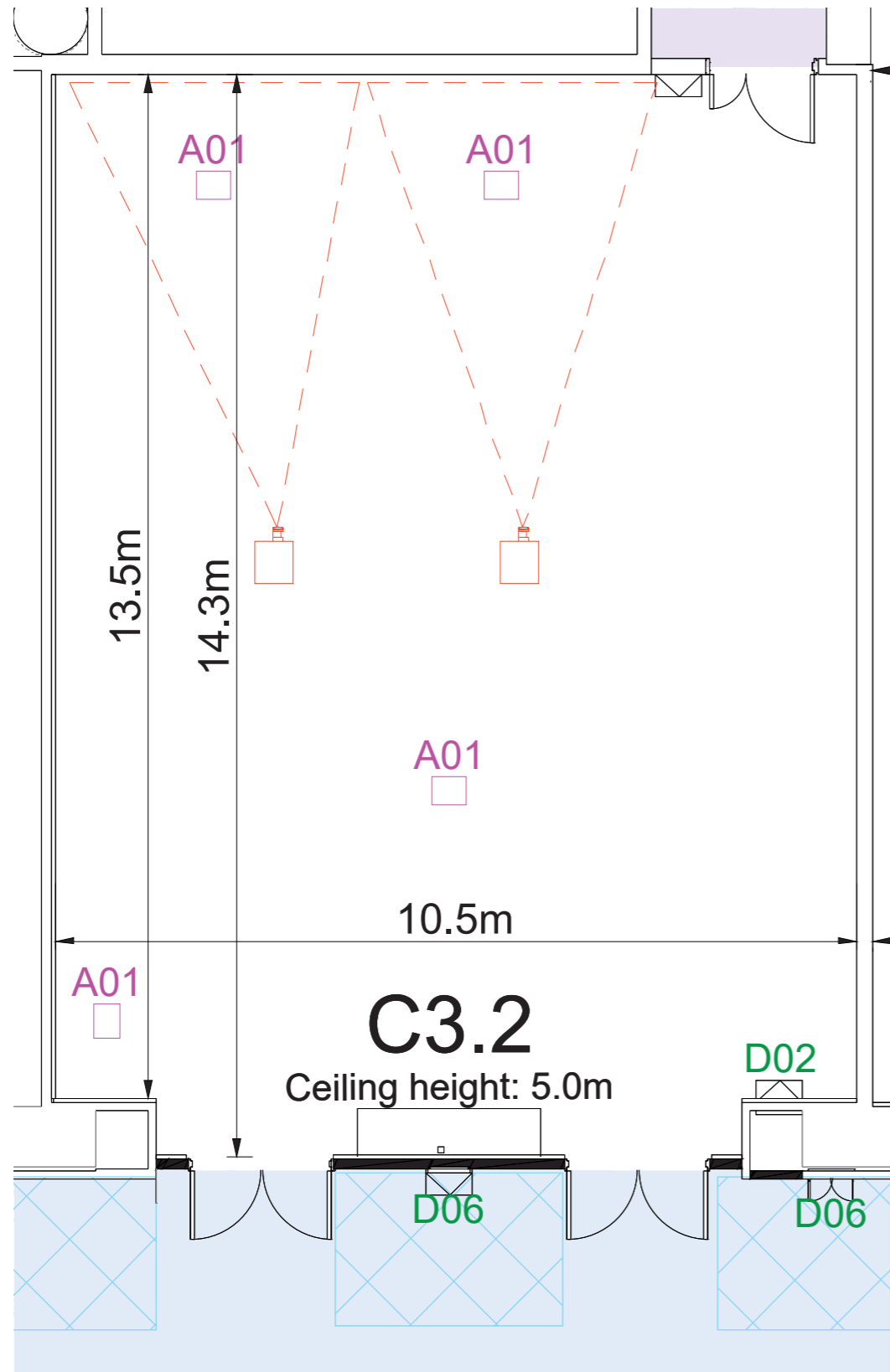

Level 3 Meeting room key plan

LEGEND

- Public Space Build Zone
- Floor Box Type A01
6 x SGPO
2 x SINGLE DATA
- Floor Box Type A07
2 x 15A SGPO
1 x 32A 3PH
2 x SINGLE DATA
- Floor Box Type A09
2 x SGPO
1 x 20A SGPO
2 x SINGLE DATA
- Floor Box Type A10
2 x SGPO
1 x 32A 3PH
2 x SINGLE DATA
- Service Cupboard 02
2 x DGPO
1 x 32A 3PH
4 x SINGLE DATA
1 x 6C SMOF
- Service Cupboard 04
2 x 15A SGPO
1 x 32A 3PH
2 x SINGLE DATA
- Service Cupboard 05
1 x DGPO
1 x 32A 3PH
2 x SINGLE DATA
- Service Cupboard 06
1 x DGPO
1 x 20A SGPO
2 x SINGLE DATA
- Rigging Point 1.0T
- Projector
- Circulation back of house
- Circulation front of house

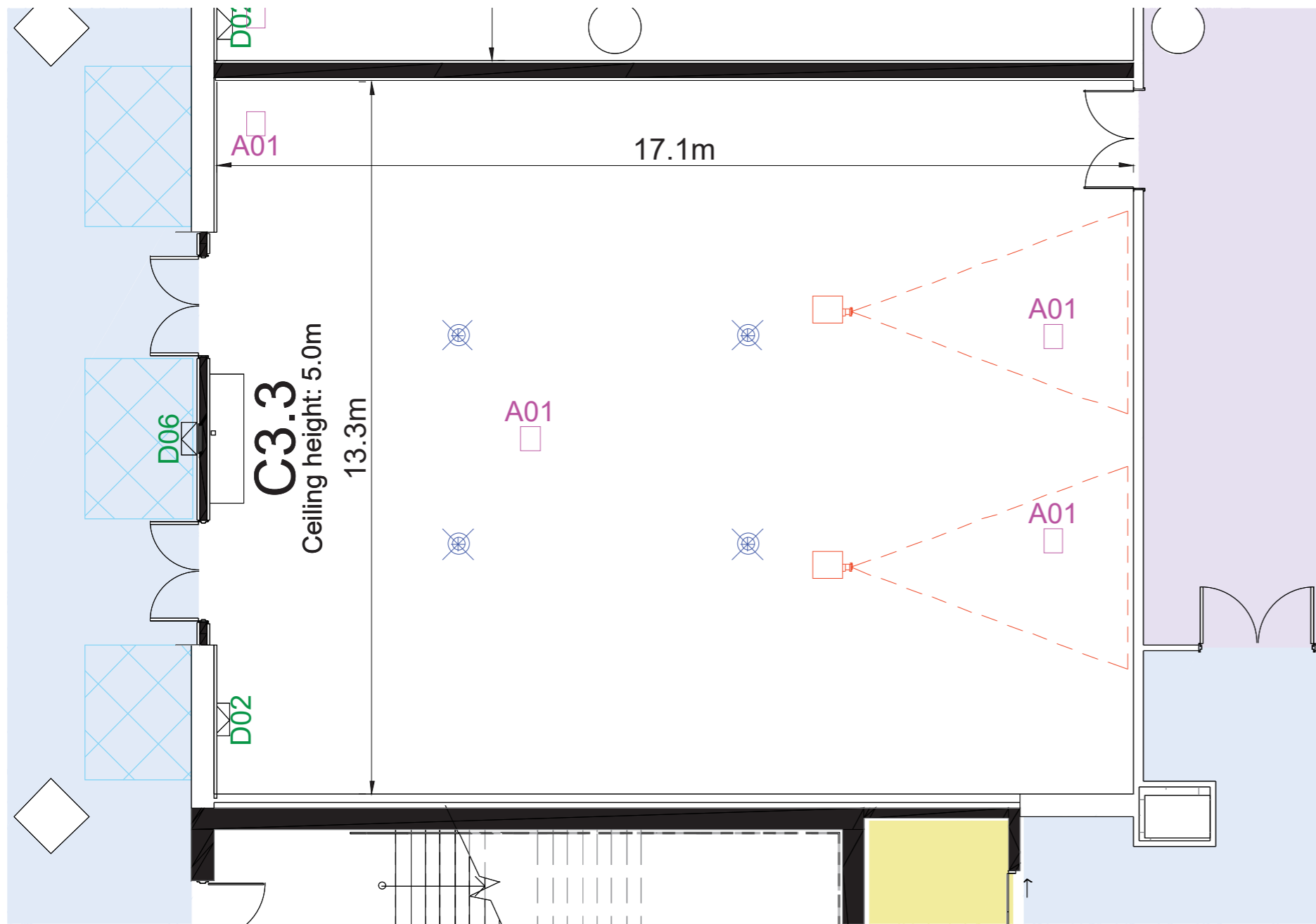

Level 3 Meeting room key plan





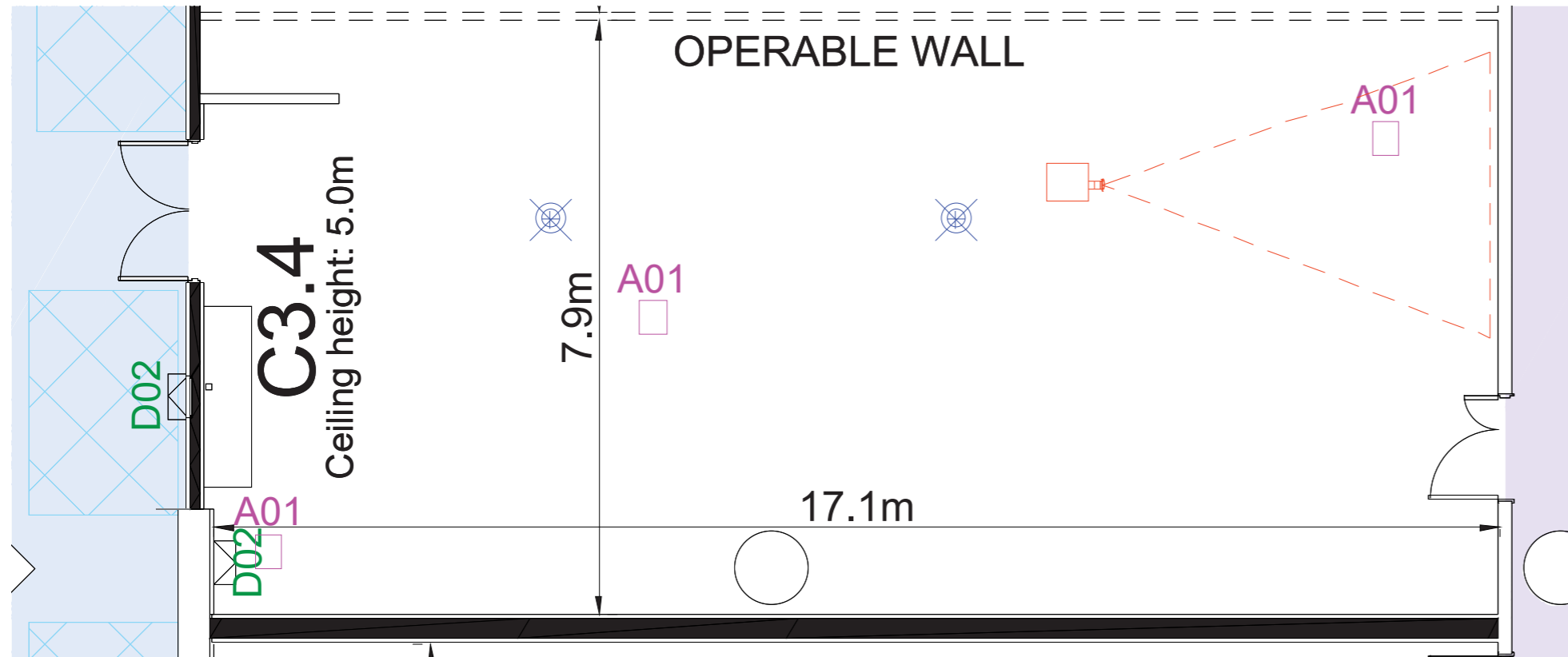







LEGEND

- Public Space Build Zone
- Circulation back of house
- Circulation front of house
- Floor Box Type A01
6 x SGPO
2 x SINGLE DATA
- Floor Box Type A07
2 x 15A SGPO
1 x 32A 3PH
2 x SINGLE DATA
- Floor Box Type A09
2 x SGPO
1 x 20A SGPO
2 x SINGLE DATA
- Floor Box Type A10
2 x SGPO
1 x 32A 3PH
2 x SINGLE DATA
- Service Cupboard 02
2 x DGPO
1 x 32A 3PH
4 x SINGLE DATA
1 x 6C SMOF
- Service Cupboard 04
2 x 15A SGPO
1 x 32A 3PH
2 x SINGLE DATA
- Service Cupboard 05
1 x DGPO
1 x 32A 3PH
2 x SINGLE DATA
- Service Cupboard 06
1 x DGPO
1 x 20A SGPO
2 x SINGLE DATA
- Rigging Point 1.0T
- Projector



Level 3 Meeting room key plan





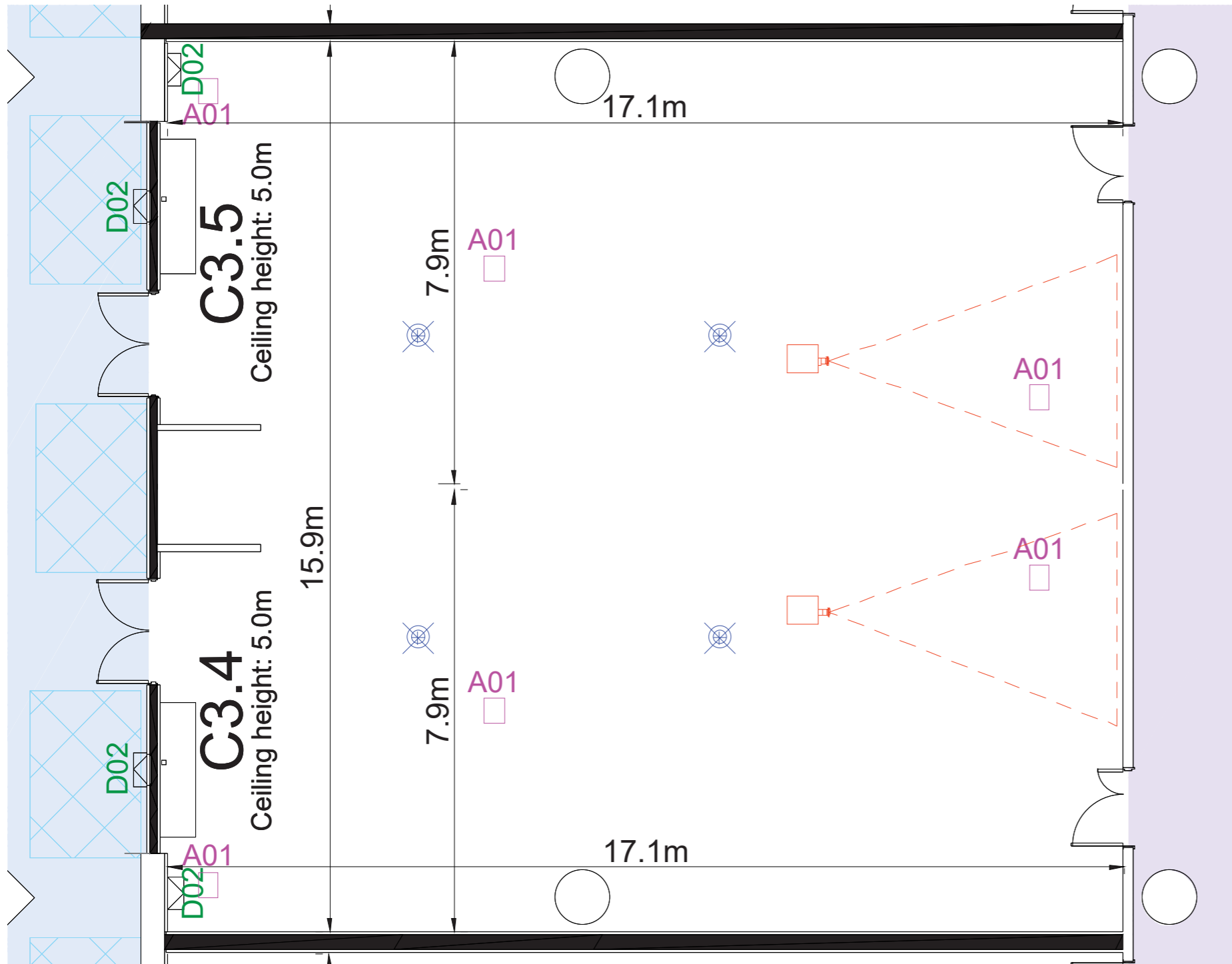







LEGEND

-  Public Space Build Zone
-  Circulation back of house
-  Circulation front of house
-  **A01** Floor Box Type A01
6 x SGPO
2 x SINGLE DATA
-  **A07** Floor Box Type A07
2 x 15A SGPO
1 x 32A 3PH
2 x SINGLE DATA
-  **A09** Floor Box Type A09
2 x SGPO
1 x 20A SGPO
2 x SINGLE DATA
-  **A10** Floor Box Type A10
2 x SGPO
1 x 32A 3PH
2 x SINGLE DATA
-  **D02** Service Cupboard 02
2 x DGPO
1 x 32A 3PH
4 x SINGLE DATA
1 x 6C SMOF
-  **D04** Service Cupboard 04
2 x 15A SGPO
1 x 32A 3PH
2 x SINGLE DATA
-  **D05** Service Cupboard 05
1 x DGPO
1 x 32A 3PH
2 x SINGLE DATA
-  **D06** Service Cupboard 06
1 x DGPO
1 x 20A SGPO
2 x SINGLE DATA
-  Rigging Point 1.0T
-  Projector



Level 3 Meeting room key plan

LEGEND

-  Public Space Build Zone
-  Floor Box Type A01
6 x SGPO
2 x SINGLE DATA
-  Floor Box Type A07
2 x 15A SGPO
1 x 32A 3PH
2 x SINGLE DATA
-  Floor Box Type A09
2 x SGPO
1 x 20A SGPO
2 x SINGLE DATA
-  Floor Box Type A10
2 x SGPO
1 x 32A 3PH
2 x SINGLE DATA
-  Service Cupboard D02
2 x DGPO
1 x 32A 3PH
4 x SINGLE DATA
1 x 6C SMOF
-  Service Cupboard D04
2 x 15A SGPO
1 x 32A 3PH
2 x SINGLE DATA
-  Service Cupboard D05
1 x DGPO
1 x 32A 3PH
2 x SINGLE DATA
-  Service Cupboard D06
1 x DGPO
1 x 20A SGPO
2 x SINGLE DATA
-  Rigging Point 1.0T
-  Projector
-  Circulation back of house
-  Circulation front of house

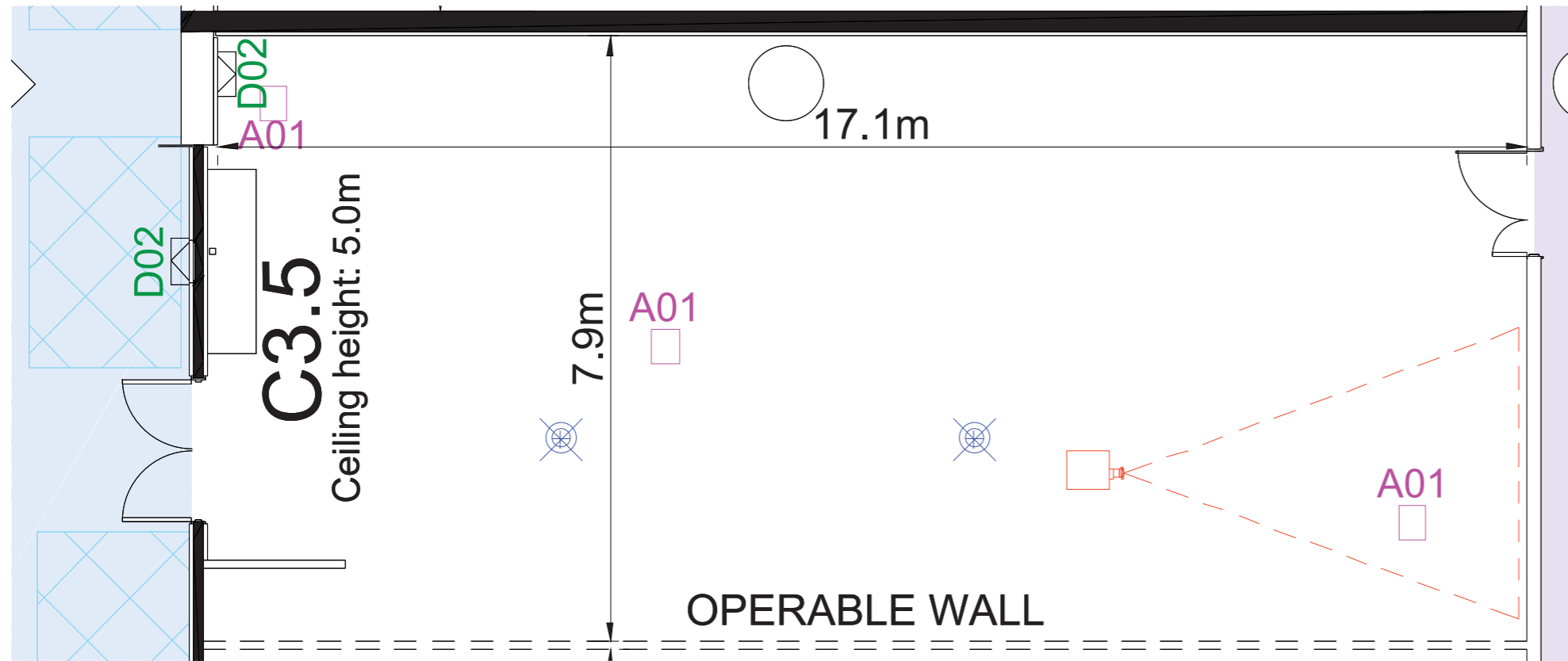

Level 3 Meeting room key plan

LEGEND

- Public Space Build Zone
- Circulation back of house
- Circulation front of house
- A01 Floor Box Type A01
6 x SGPO
2 x SINGLE DATA
- A07 Floor Box Type A07
2 x 15A SGPO
1 x 32A 3PH
2 x SINGLE DATA
- A09 Floor Box Type A09
2 x SGPO
1 x 20A SGPO
2 x SINGLE DATA
- A10 Floor Box Type A10
2 x SGPO
1 x 32A 3PH
2 x SINGLE DATA
- D02 Service Cupboard 02
2 x DGPO
1 x 32A 3PH
4 x SINGLE DATA
1 x 6C SMOF
- D04 Service Cupboard 04
2 x 15A SGPO
1 x 32A 3PH
2 x SINGLE DATA
- D05 Service Cupboard 05
1 x DGPO
1 x 32A 3PH
2 x SINGLE DATA
- D06 Service Cupboard 06
1 x DGPO
1 x 20A SGPO
2 x SINGLE DATA
- Rigging Point 1.0T
- Projector

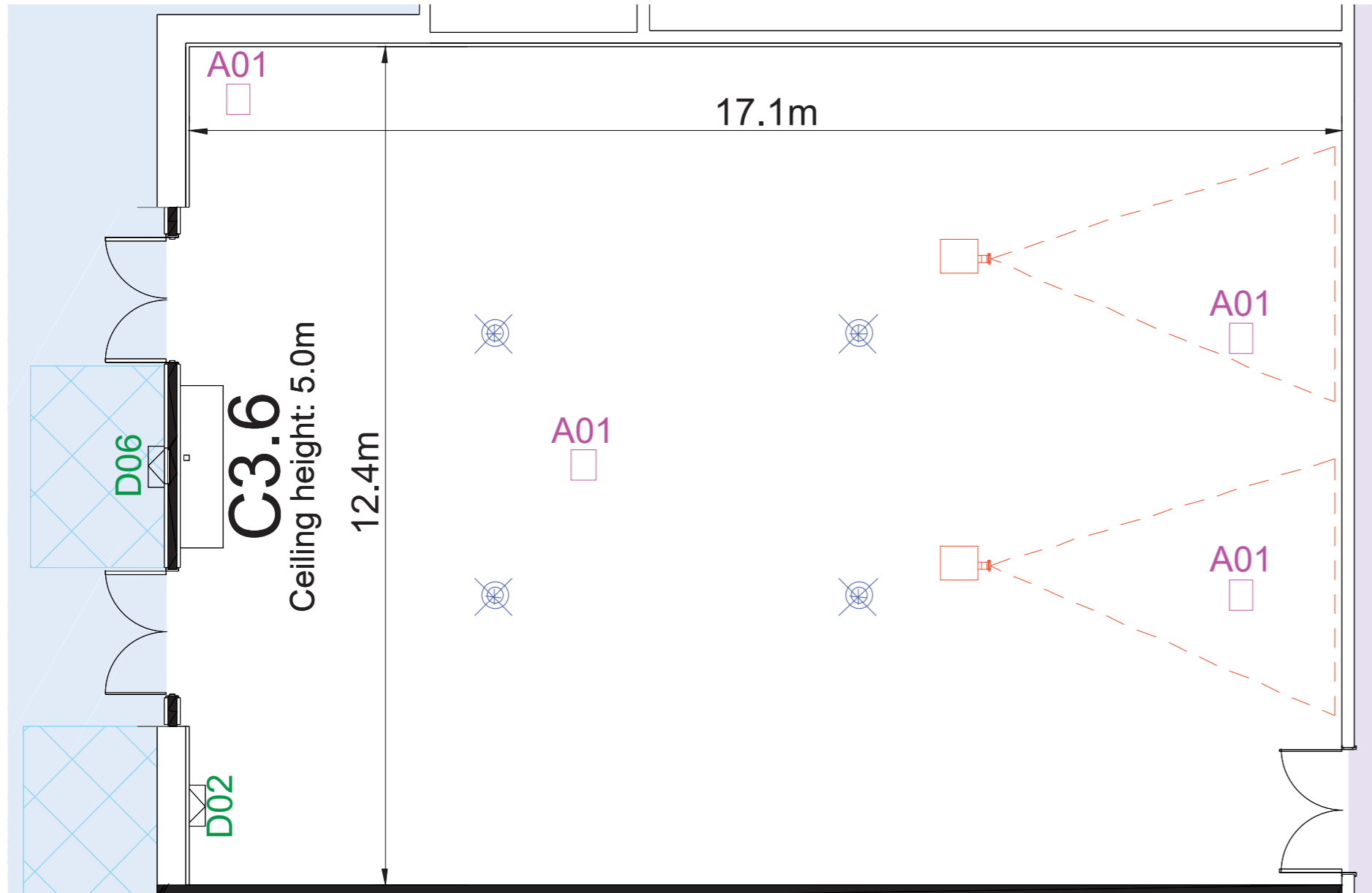

Level 3 Meeting room key plan

LEGEND

- Public Space Build Zone
- Circulation back of house
- Circulation front of house
- A01** Floor Box Type A01
6 x SGPO
2 x SINGLE DATA
- A07** Floor Box Type A07
2 x 15A SGPO
1 x 32A 3PH
2 x SINGLE DATA
- A09** Floor Box Type A09
2 x SGPO
1 x 20A SGPO
2 x SINGLE DATA
- A10** Floor Box Type A10
2 x SGPO
1 x 32A 3PH
2 x SINGLE DATA
- D02** Service Cupboard 02
2 x DGPO
1 x 32A 3PH
4 x SINGLE DATA
1 x 6C SMOF
- D04** Service Cupboard 04
2 x 15A SGPO
1 x 32A 3PH
2 x SINGLE DATA
- D05** Service Cupboard 05
1 x DGPO
1 x 32A 3PH
2 x SINGLE DATA
- D06** Service Cupboard 06
1 x DGPO
1 x 20A SGPO
2 x SINGLE DATA
- Rigging Point 1.0T
- Projector

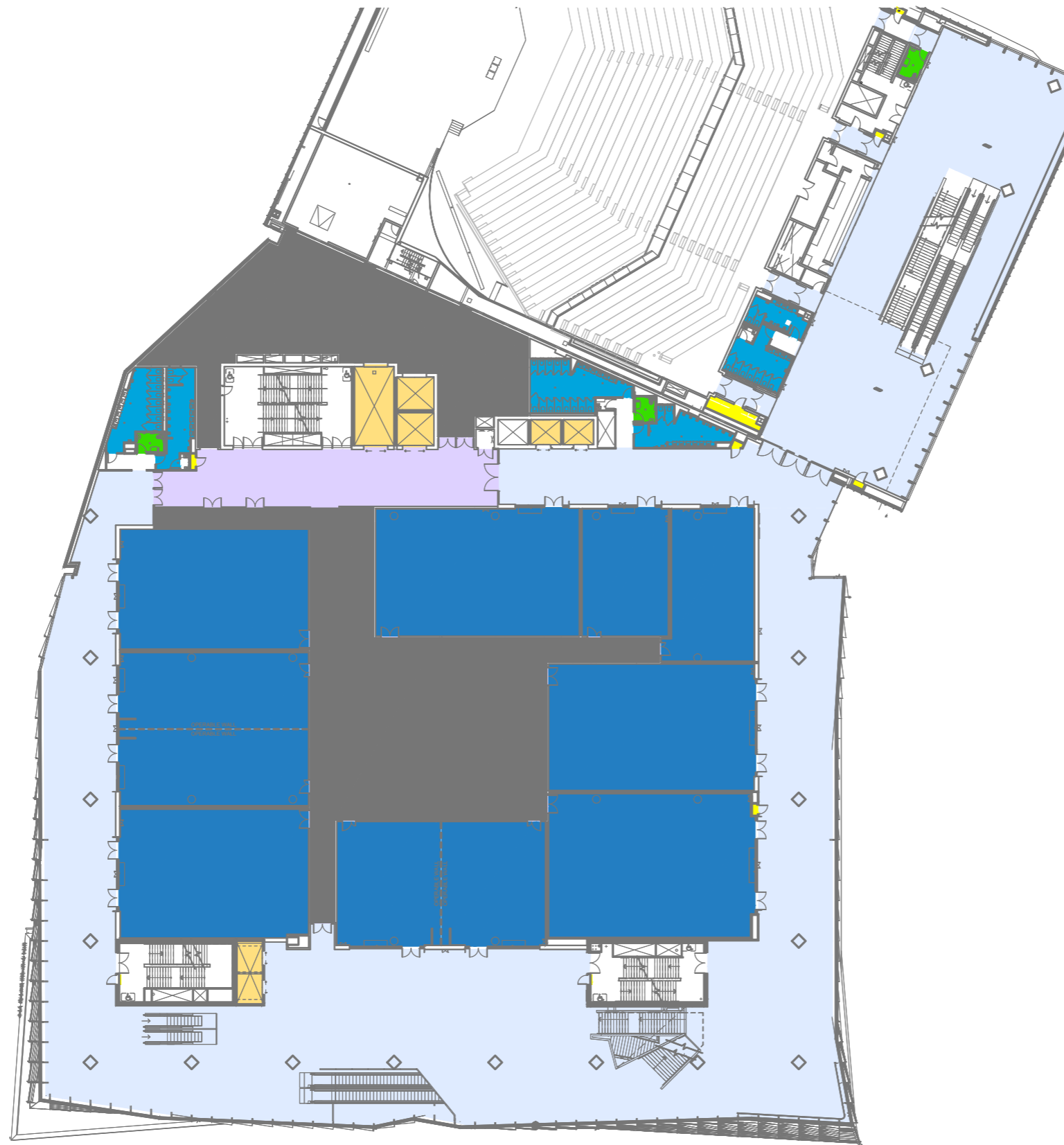

Axonometric cutaway view of Level 4 Convention Centre

LEGEND

- Back of House
- Circulation Back of House
- Circulation Front of House
- Lifts
- Fire Hydrants
- Toilets / Facilities
- Accessible Toilet
- Rooms C4.1 - C4.11

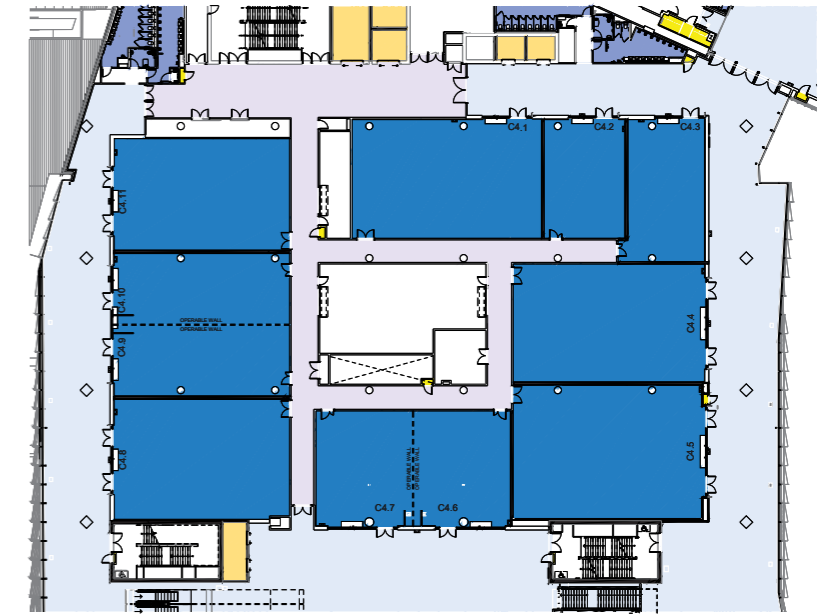
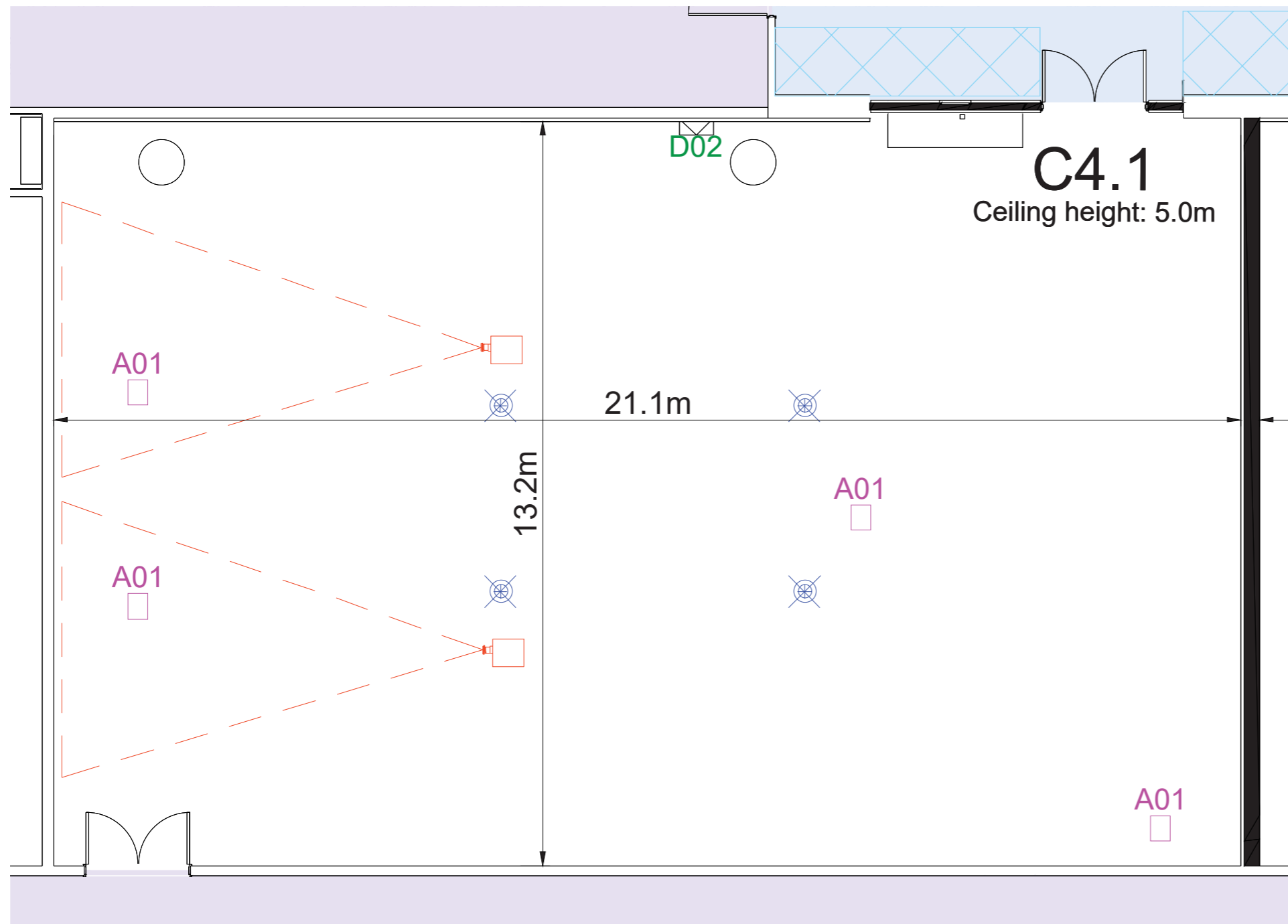

LEGEND

- Public Space Build Zone
- Circulation back of house
- Circulation front of house
- A01** Floor Box Type A01
6 x SGPO
2 x SINGLE DATA
- A07** Floor Box Type A07
2 x 15A SGPO
1 x 32A 3PH
2 x SINGLE DATA
- A09** Floor Box Type A09
2 x SGPO
1 x 20A SGPO
2 x SINGLE DATA
- A10** Floor Box Type A10
2 x SGPO
1 x 32A 3PH
2 x SINGLE DATA
- D02** Service Cupboard 02
2 x DGPO
1 x 32A 3PH
4 x SINGLE DATA
1 x 6C SMOF
- D04** Service Cupboard 04
2 x 15A SGPO
1 x 32A 3PH
2 x SINGLE DATA
- D05** Service Cupboard 05
1 x DGPO
1 x 32A 3PH
2 x SINGLE DATA
- D06** Service Cupboard 06
1 x DGPO
1 x 20A SGPO
2 x SINGLE DATA
- Rigging Point 1.0T
- Projector

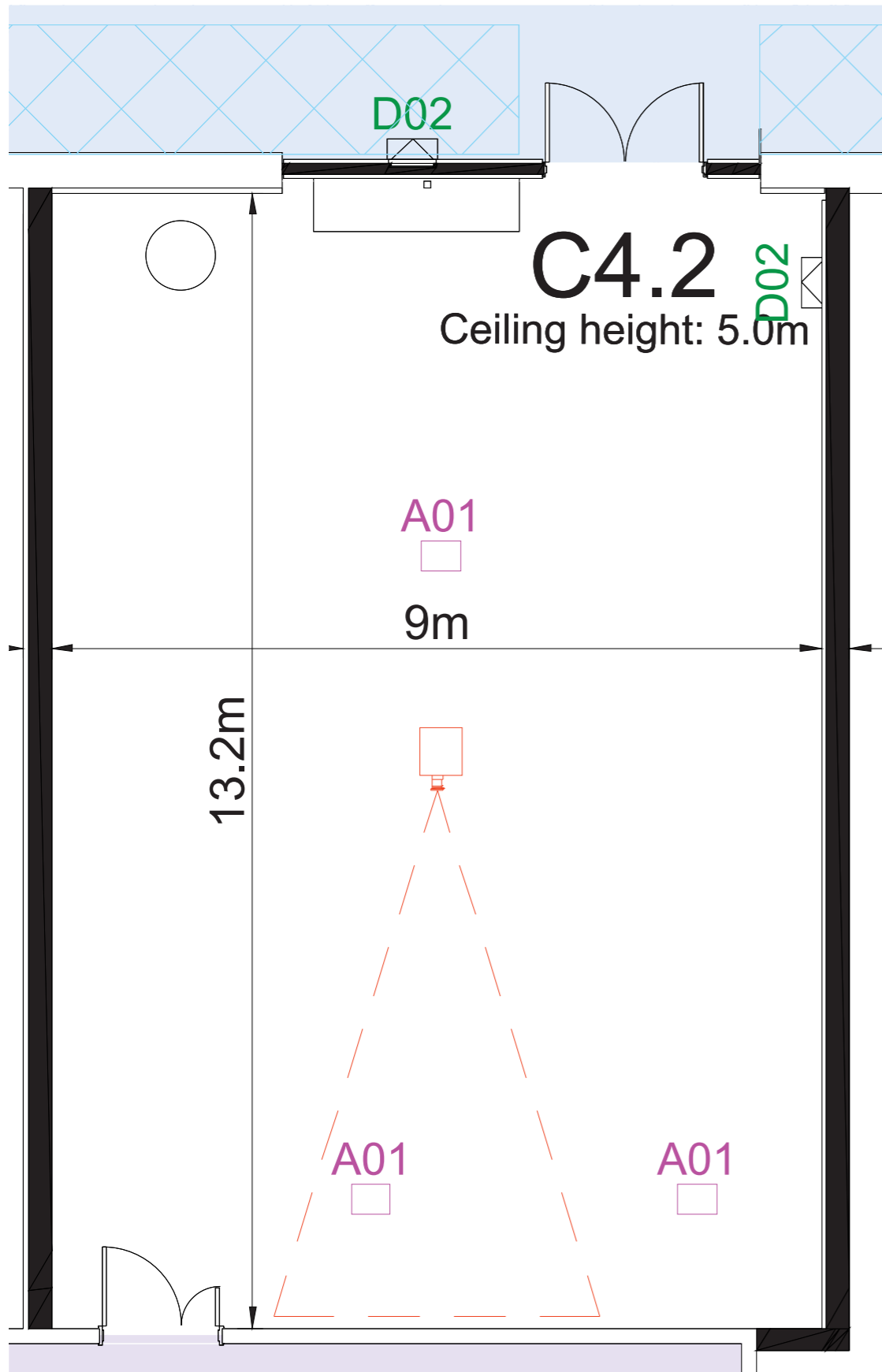

LEGEND

- Public Space Build Zone
- Circulation back of house
- Circulation front of house
- A01** Floor Box Type A01
6 x SGPO
2 x SINGLE DATA
- A07** Floor Box Type A07
2 x 15A SGPO
1 x 32A 3PH
2 x SINGLE DATA
- A09** Floor Box Type A09
2 x SGPO
1 x 20A SGPO
2 x SINGLE DATA
- A10** Floor Box Type A10
2 x SGPO
1 x 32A 3PH
2 x SINGLE DATA
- D02** Service Cupboard 02
2 x DGPO
1 x 32A 3PH
4 x SINGLE DATA
1 x 6C SMOF
- D04** Service Cupboard 04
2 x 15A SGPO
1 x 32A 3PH
2 x SINGLE DATA
- D05** Service Cupboard 05
1 x DGPO
1 x 32A 3PH
2 x SINGLE DATA
- D06** Service Cupboard 06
1 x DGPO
1 x 20A SGPO
2 x SINGLE DATA
- Rigging Point 1.0T
- Projector

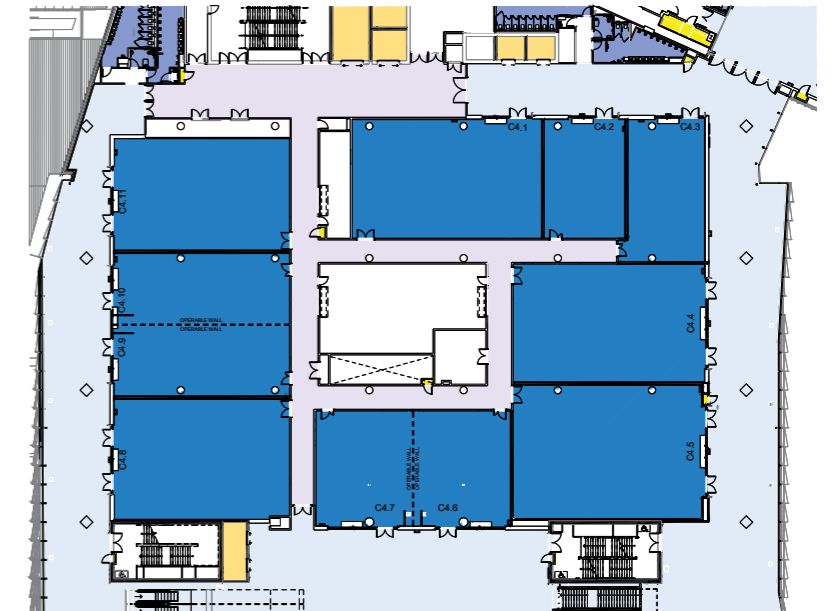
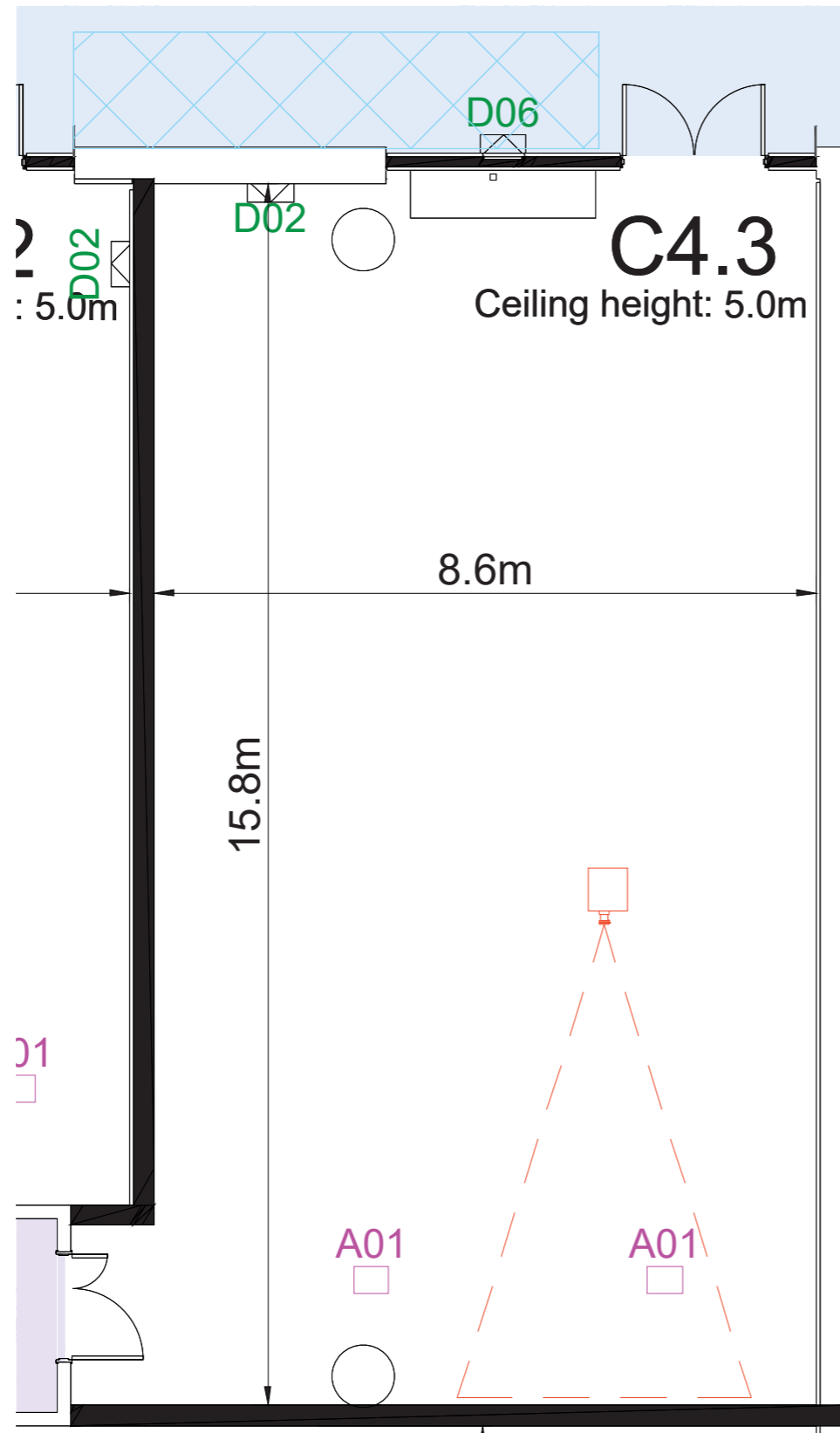

LEGEND

- Public Space Build Zone
- Circulation back of house
- Circulation front of house
- A01** Floor Box Type A01
6 x SGPO
2 x SINGLE DATA
- A07** Floor Box Type A07
2 x 15A SGPO
1 x 32A 3PH
2 x SINGLE DATA
- A09** Floor Box Type A09
2 x SGPO
1 x 20A SGPO
2 x SINGLE DATA
- A10** Floor Box Type A10
2 x SGPO
1 x 32A 3PH
2 x SINGLE DATA
- D02** Service Cupboard 02
2 x DGPO
1 x 32A 3PH
4 x SINGLE DATA
1 x 6C SMOF
- D04** Service Cupboard 04
2 x 15A SGPO
1 x 32A 3PH
2 x SINGLE DATA
- D05** Service Cupboard 05
1 x DGPO
1 x 32A 3PH
2 x SINGLE DATA
- D06** Service Cupboard 06
1 x DGPO
1 x 20A SGPO
2 x SINGLE DATA
- Rigging Point 1.0T
- Projector

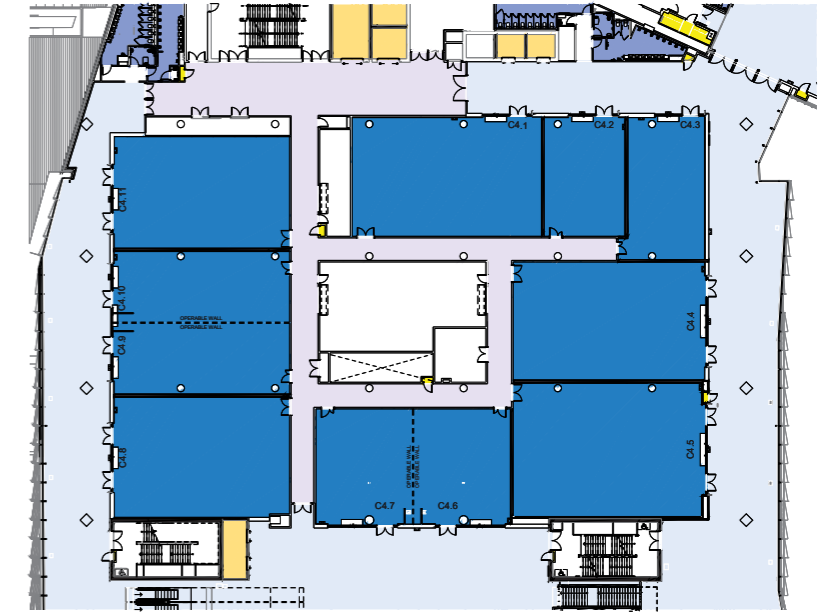
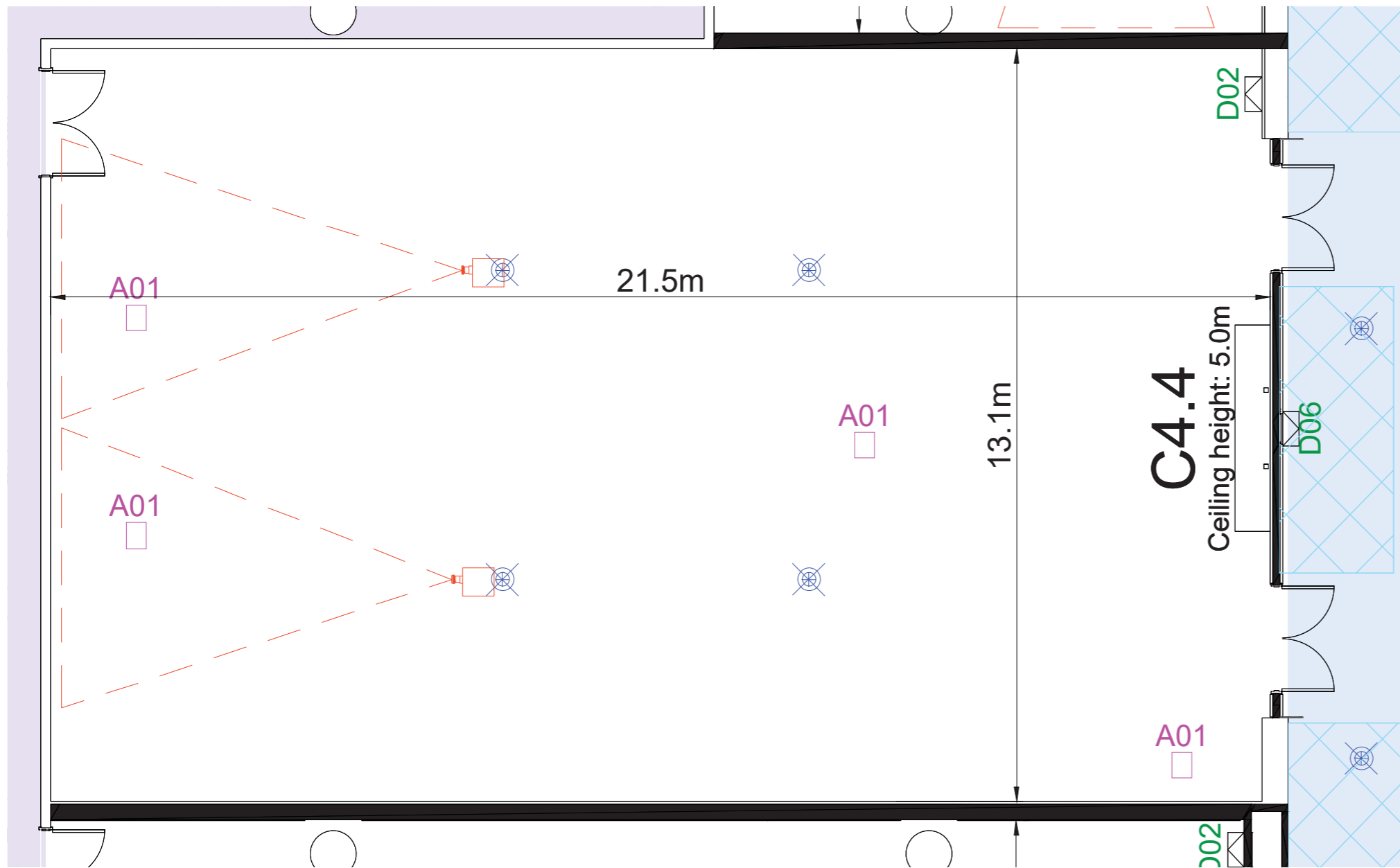

LEGEND

- Public Space Build Zone
- Circulation back of house
- Circulation front of house
- A01** Floor Box Type A01
6 x SGPO
2 x SINGLE DATA
- A07** Floor Box Type A07
2 x 15A SGPO
1 x 32A 3PH
2 x SINGLE DATA
- A09** Floor Box Type A09
2 x SGPO
1 x 20A SGPO
2 x SINGLE DATA
- A10** Floor Box Type A10
2 x SGPO
1 x 32A 3PH
2 x SINGLE DATA
- D02** Service Cupboard 02
2 x DGPO
1 x 32A 3PH
4 x SINGLE DATA
1 x 6C SMOF
- D04** Service Cupboard 04
2 x 15A SGPO
1 x 32A 3PH
2 x SINGLE DATA
- D05** Service Cupboard 05
1 x DGPO
1 x 32A 3PH
2 x SINGLE DATA
- D06** Service Cupboard 06
1 x DGPO
1 x 20A SGPO
2 x SINGLE DATA
- Rigging Point 1.0T
- Projector

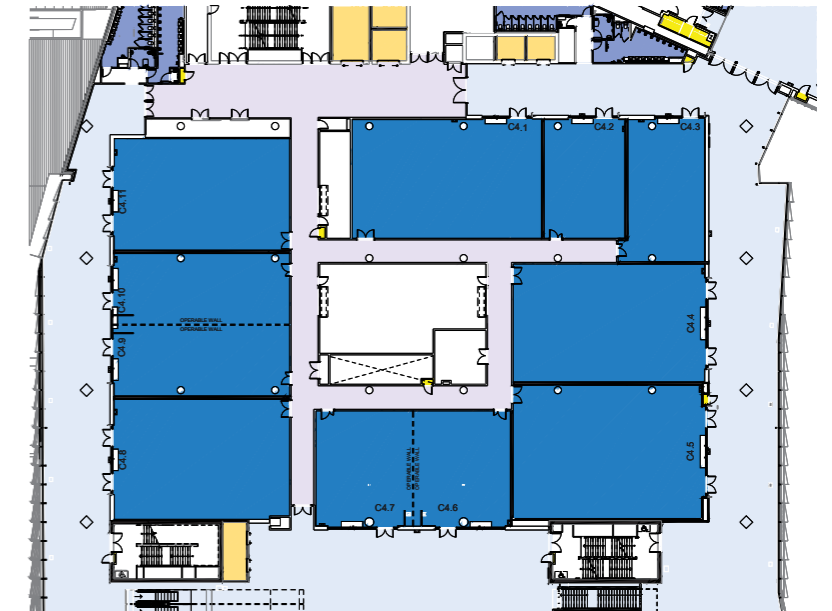
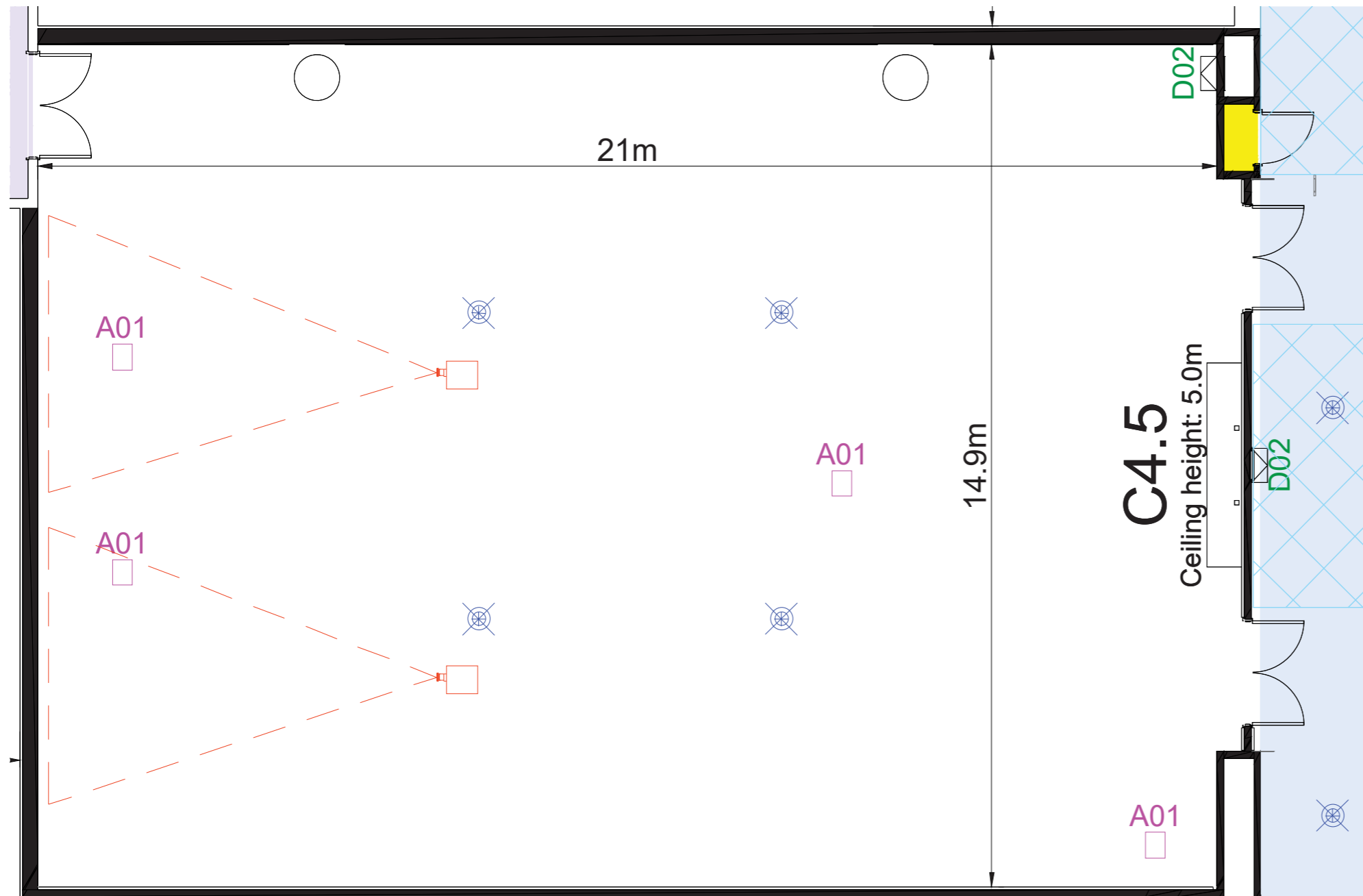



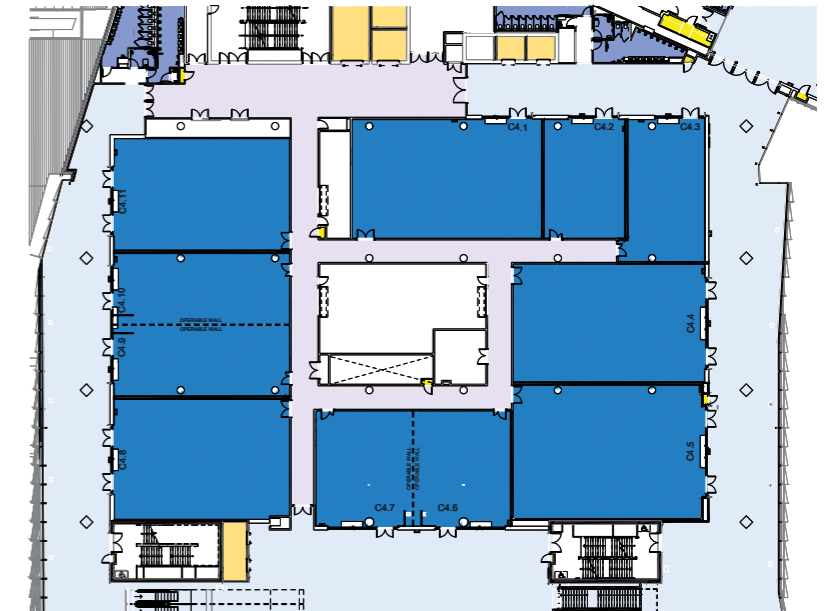
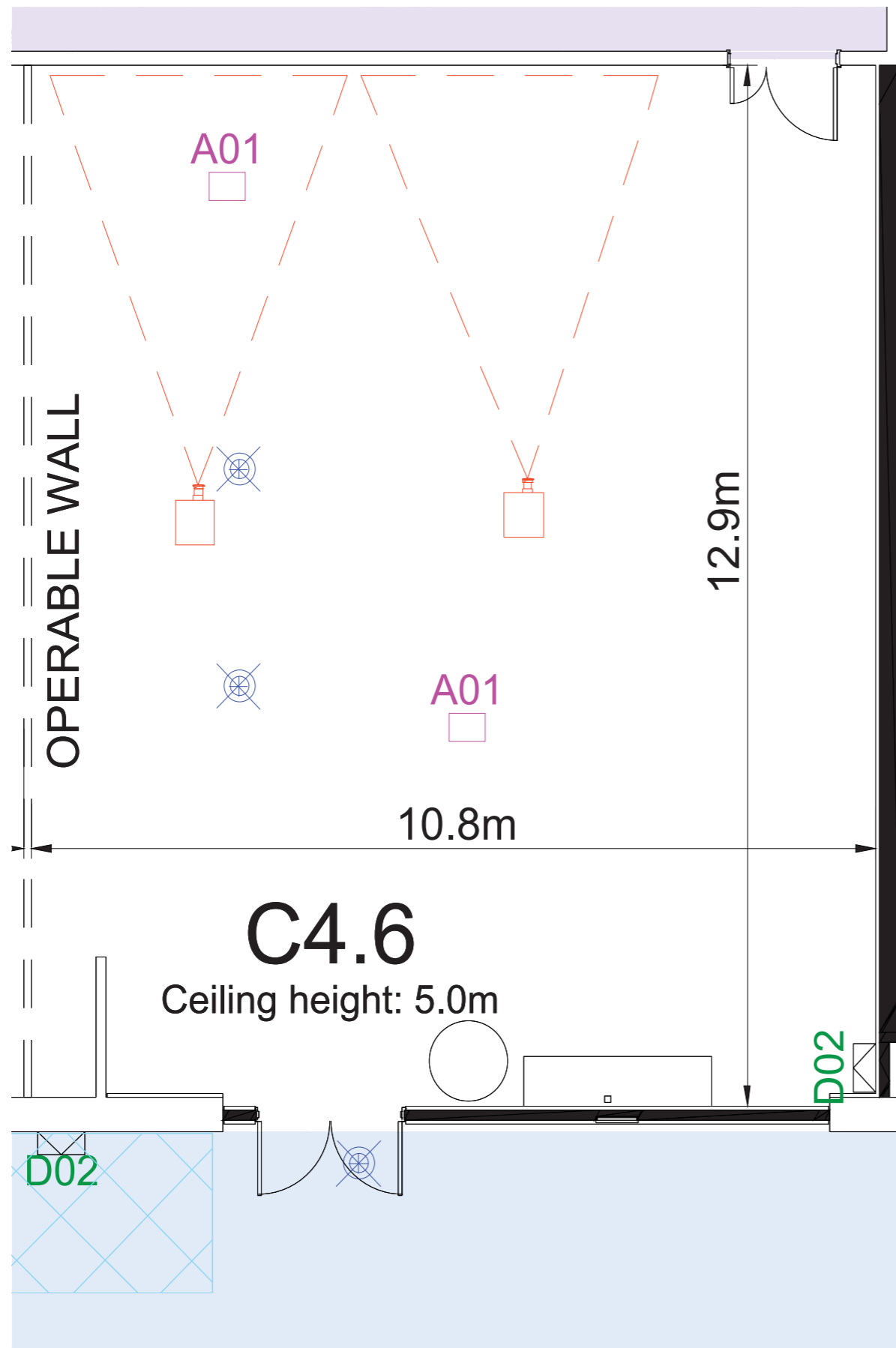

Level 4 Convention Centre

LEGEND

- Public Space Build Zone
- Circulation back of house
- Circulation front of house
- A01** Floor Box Type A01
6 x SGPO
2 x SINGLE DATA
- A07** Floor Box Type A07
2 x 15A SGPO
1 x 32A 3PH
2 x SINGLE DATA
- A09** Floor Box Type A09
2 x SGPO
1 x 20A SGPO
2 x SINGLE DATA
- A10** Floor Box Type A10
2 x SGPO
1 x 32A 3PH
2 x SINGLE DATA
- D02** Service Cupboard 02
2 x DGPO
1 x 32A 3PH
4 x SINGLE DATA
1 x 6C SMOF
- D04** Service Cupboard 04
2 x 15A SGPO
1 x 32A 3PH
2 x SINGLE DATA
- D05** Service Cupboard 05
1 x DGPO
1 x 32A 3PH
2 x SINGLE DATA
- D06** Service Cupboard 06
1 x DGPO
1 x 20A SGPO
2 x SINGLE DATA
- Rigging Point 1.0T
- Projector



LEGEND

-  Public Space Build Zone
-  Circulation back of house
-  Circulation front of house
- A01** Floor Box Type A01
6 x SGPO
2 x SINGLE DATA
- A07** Floor Box Type A07
2 x 15A SGPO
1 x 32A 3PH
2 x SINGLE DATA
- A09** Floor Box Type A09
2 x SGPO
1 x 20A SGPO
2 x SINGLE DATA
- A10** Floor Box Type A10
2 x SGPO
1 x 32A 3PH
2 x SINGLE DATA
- D02** Service Cupboard 02
2 x DGPO
1 x 32A 3PH
4 x SINGLE DATA
1 x 6C SMOF
- D04** Service Cupboard 04
2 x 15A SGPO
1 x 32A 3PH
2 x SINGLE DATA
- D05** Service Cupboard 05
1 x DGPO
1 x 32A 3PH
2 x SINGLE DATA
- D06** Service Cupboard 06
1 x DGPO
1 x 20A SGPO
2 x SINGLE DATA
-  Rigging Point 1.0T
-  Projector

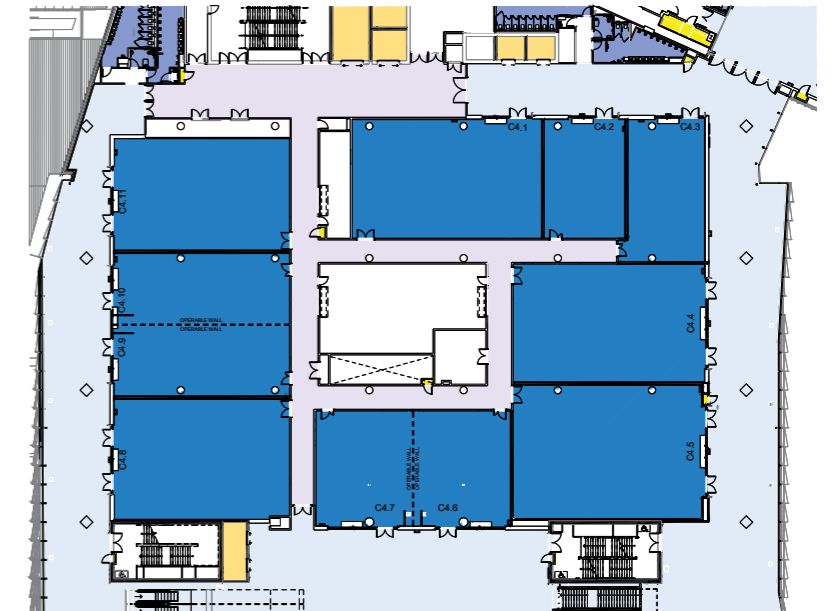
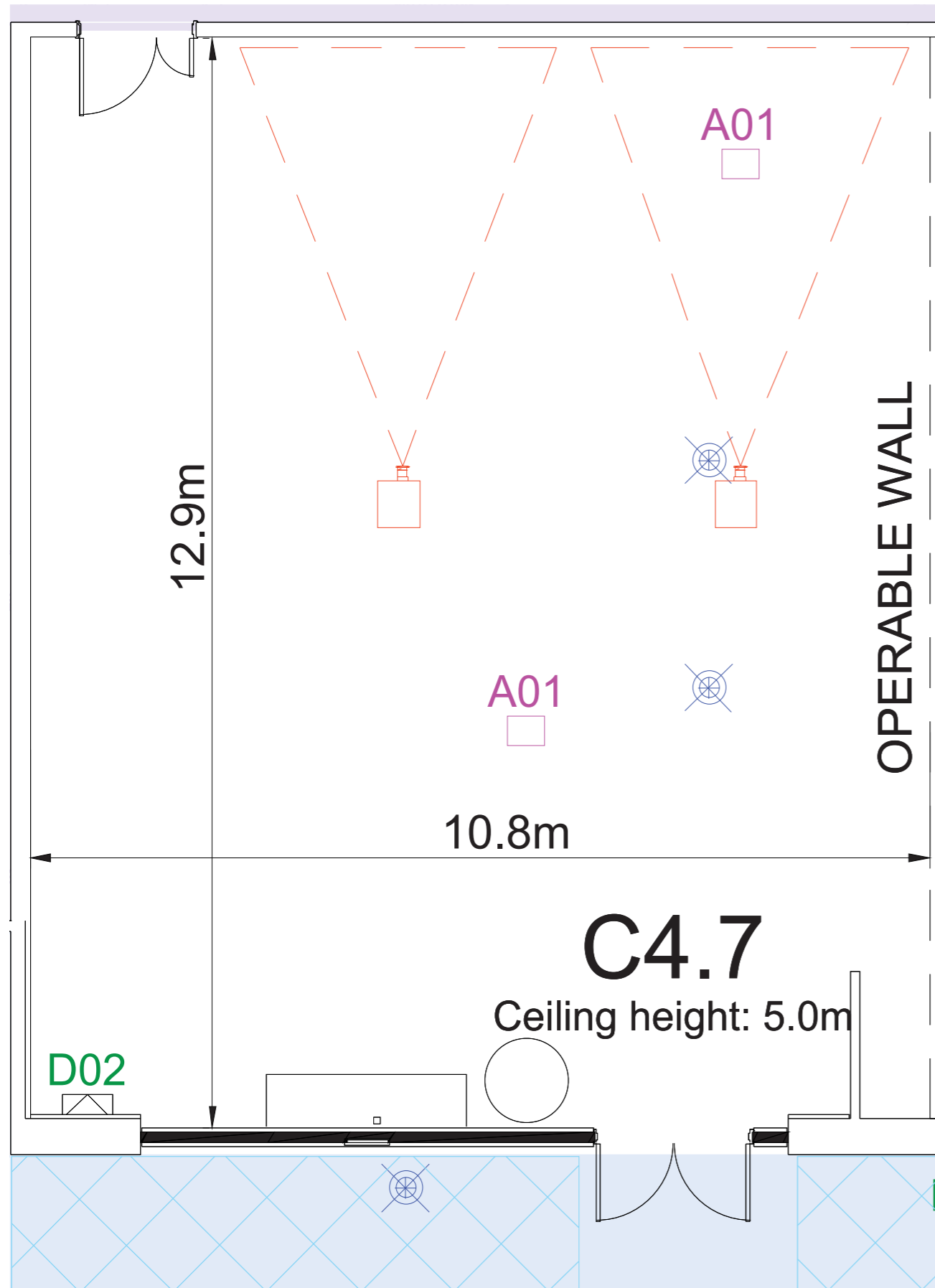



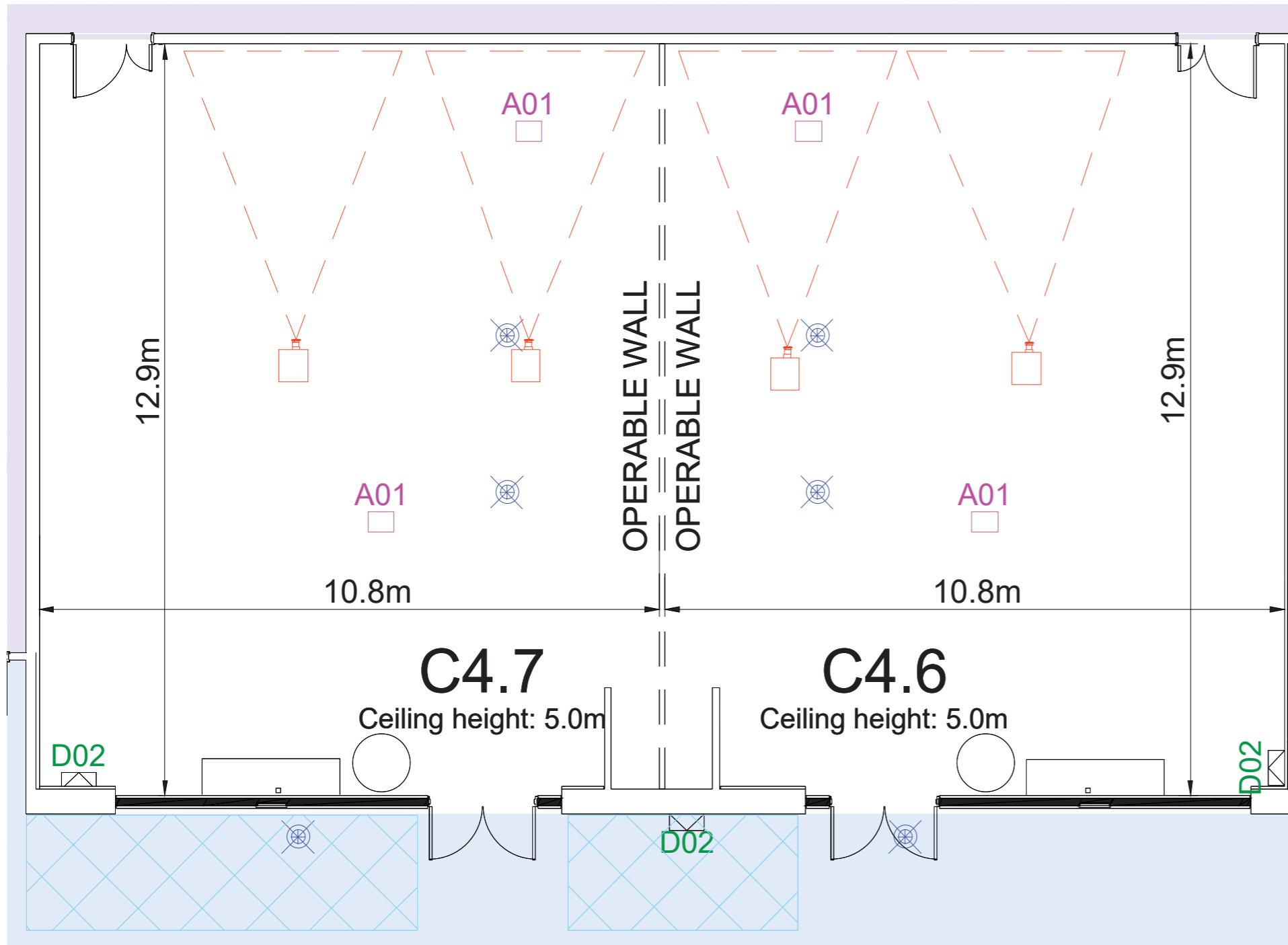

LEGEND

- Public Space Build Zone
- Circulation back of house
- Circulation front of house
- A01** Floor Box Type A01
6 x SGPO
2 x SINGLE DATA
- A07** Floor Box Type A07
2 x 15A SGPO
1 x 32A 3PH
2 x SINGLE DATA
- A09** Floor Box Type A09
2 x SGPO
1 x 20A SGPO
2 x SINGLE DATA
- A10** Floor Box Type A10
2 x SGPO
1 x 32A 3PH
2 x SINGLE DATA
- D02** Service Cupboard 02
2 x DGPO
1 x 32A 3PH
4 x SINGLE DATA
1 x 6C SMOF
- D04** Service Cupboard 04
2 x 15A SGPO
1 x 32A 3PH
2 x SINGLE DATA
- D05** Service Cupboard 05
1 x DGPO
1 x 32A 3PH
2 x SINGLE DATA
- D06** Service Cupboard 06
1 x DGPO
1 x 20A SGPO
2 x SINGLE DATA
- Rigging Point 1.0T
- Projector



Level 4 Convention Centre

LEGEND

-  Public Space Build Zone
-  Circulation back of house
-  Circulation front of house
- A01** Floor Box Type A01
6 x SGPO
2 x SINGLE DATA
- A07** Floor Box Type A07
2 x 15A SGPO
1 x 32A 3PH
2 x SINGLE DATA
- A09** Floor Box Type A09
2 x SGPO
1 x 20A SGPO
2 x SINGLE DATA
- A10** Floor Box Type A10
2 x SGPO
1 x 32A 3PH
2 x SINGLE DATA
- D02** Service Cupboard 02
2 x DGPO
1 x 32A 3PH
4 x SINGLE DATA
1 x 6C SMOF
- D04** Service Cupboard 04
2 x 15A SGPO
1 x 32A 3PH
2 x SINGLE DATA
- D05** Service Cupboard 05
1 x DGPO
1 x 32A 3PH
2 x SINGLE DATA
- D06** Service Cupboard 06
1 x DGPO
1 x 20A SGPO
2 x SINGLE DATA
-  Rigging Point 1.0T
-  Projector

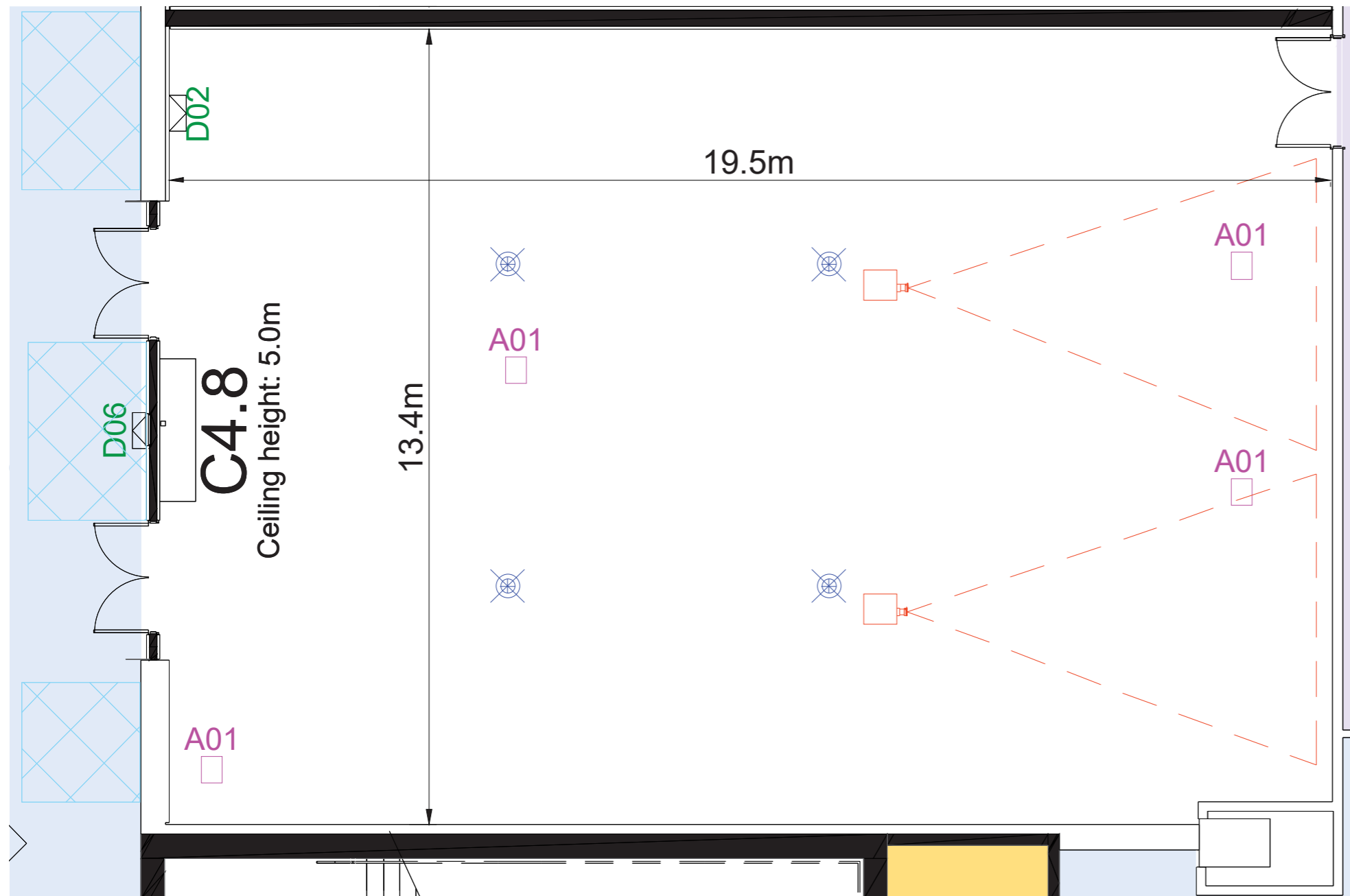



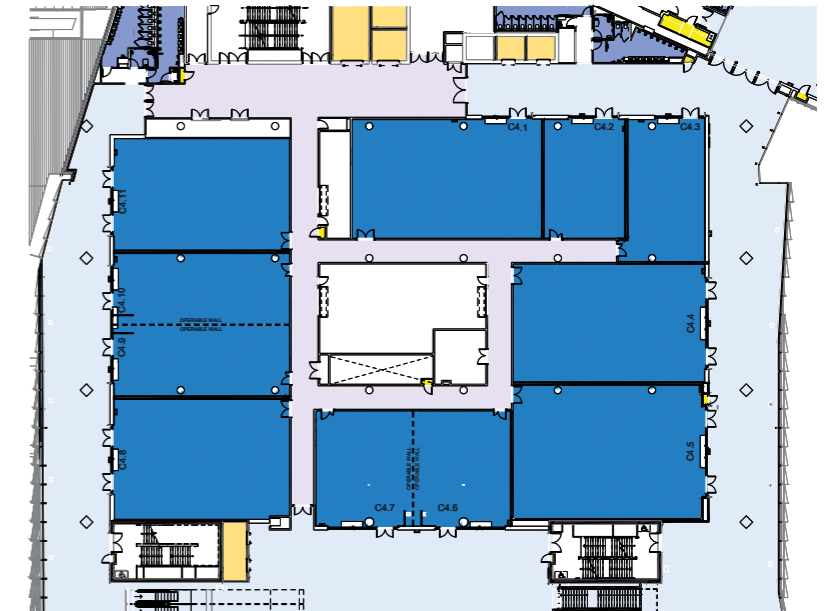
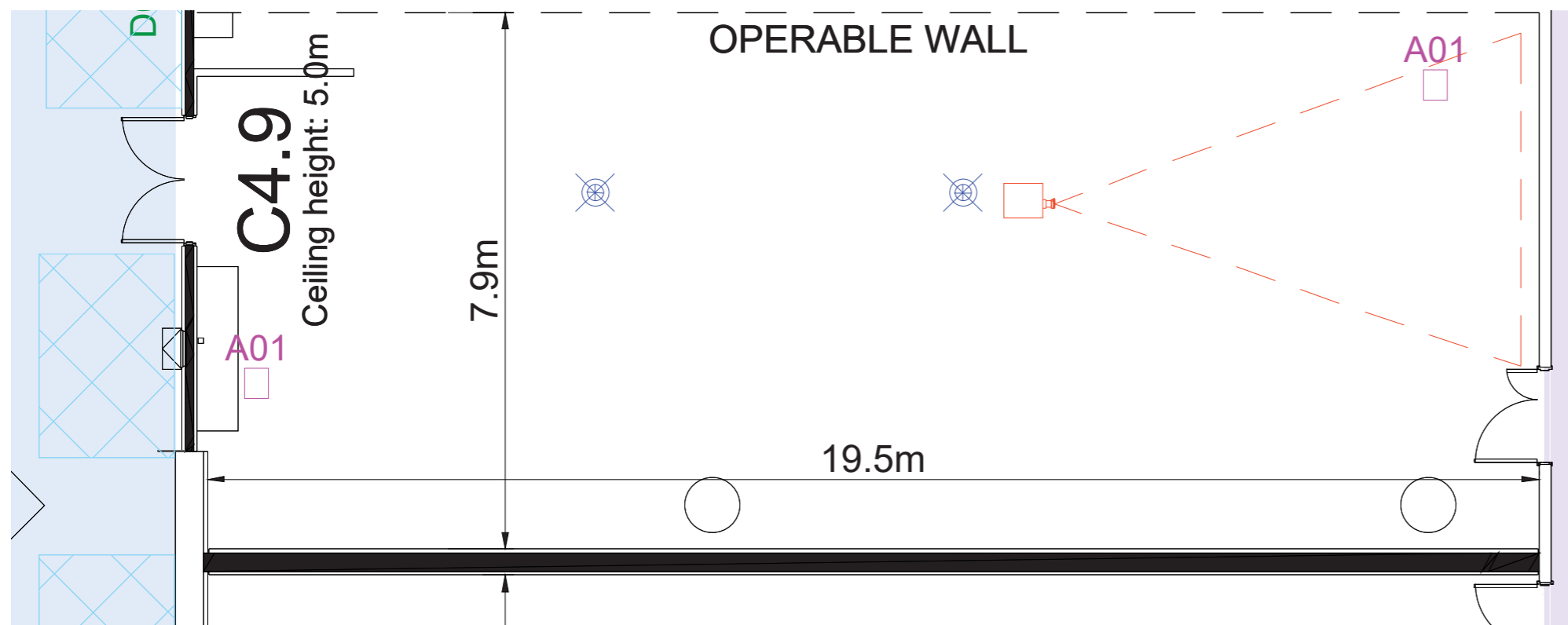

Level 4 Convention Centre

LEGEND

- Public Space Build Zone
- Circulation back of house
- Circulation front of house
- A01** Floor Box Type A01
6 x SGPO
2 x SINGLE DATA
- A07** Floor Box Type A07
2 x 15A SGPO
1 x 32A 3PH
2 x SINGLE DATA
- A09** Floor Box Type A09
2 x SGPO
1 x 20A SGPO
2 x SINGLE DATA
- A10** Floor Box Type A10
2 x SGPO
1 x 32A 3PH
2 x SINGLE DATA
- D02** Service Cupboard 02
2 x DGPO
1 x 32A 3PH
4 x SINGLE DATA
1 x 6C SMOF
- D04** Service Cupboard 04
2 x 15A SGPO
1 x 32A 3PH
2 x SINGLE DATA
- D05** Service Cupboard 05
1 x DGPO
1 x 32A 3PH
2 x SINGLE DATA
- D06** Service Cupboard 06
1 x DGPO
1 x 20A SGPO
2 x SINGLE DATA
- Rigging Point 1.0T
- Projector



LEGEND

-  Public Space Build Zone
-  Circulation back of house
-  Circulation front of house
- A01** Floor Box Type A01
6 x SGPO
2 x SINGLE DATA
- A07** Floor Box Type A07
2 x 15A SGPO
1 x 32A 3PH
2 x SINGLE DATA
- A09** Floor Box Type A09
2 x SGPO
1 x 20A SGPO
2 x SINGLE DATA
- A10** Floor Box Type A10
2 x SGPO
1 x 32A 3PH
2 x SINGLE DATA
- D02** Service Cupboard 02
2 x DGPO
1 x 32A 3PH
4 x SINGLE DATA
1 x 6C SMOF
- D04** Service Cupboard 04
2 x 15A SGPO
1 x 32A 3PH
2 x SINGLE DATA
- D05** Service Cupboard 05
1 x DGPO
1 x 32A 3PH
2 x SINGLE DATA
- D06** Service Cupboard 06
1 x DGPO
1 x 20A SGPO
2 x SINGLE DATA
-  Rigging Point 1.0T
-  Projector

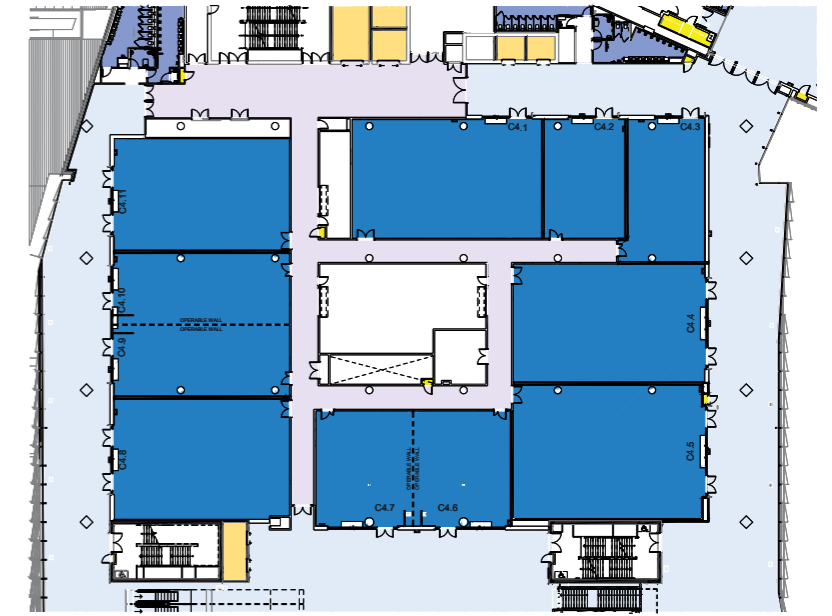
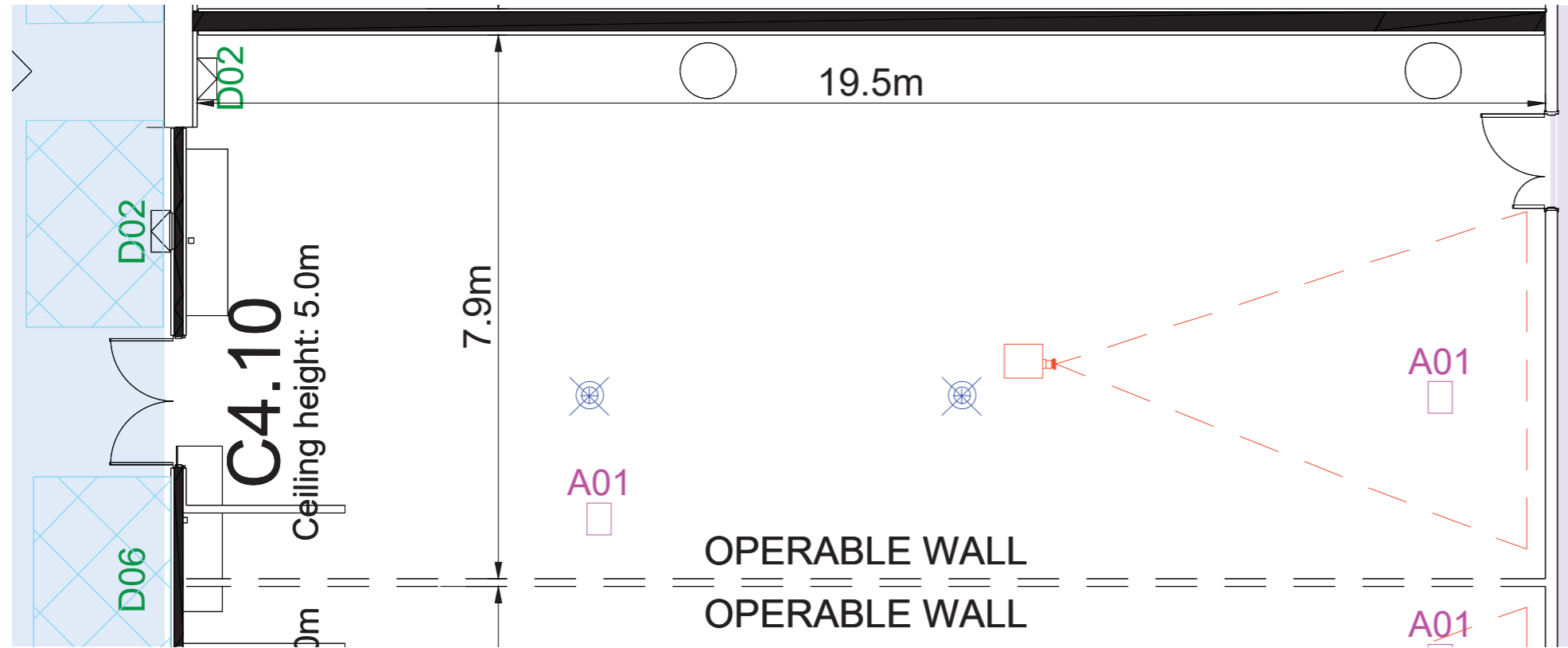

LEGEND

- Public Space Build Zone
- Circulation back of house
- Circulation front of house
- A01** Floor Box Type A01
6 x SGPO
2 x SINGLE DATA
- A07** Floor Box Type A07
2 x 15A SGPO
1 x 32A 3PH
2 x SINGLE DATA
- A09** Floor Box Type A09
2 x SGPO
1 x 20A SGPO
2 x SINGLE DATA
- A10** Floor Box Type A10
2 x SGPO
1 x 32A 3PH
2 x SINGLE DATA
- D02** Service Cupboard 02
2 x DGPO
1 x 32A 3PH
4 x SINGLE DATA
1 x 6C SMOF
- D04** Service Cupboard 04
2 x 15A SGPO
1 x 32A 3PH
2 x SINGLE DATA
- D05** Service Cupboard 05
1 x DGPO
1 x 32A 3PH
2 x SINGLE DATA
- D06** Service Cupboard 06
1 x DGPO
1 x 20A SGPO
2 x SINGLE DATA
- Rigging Point 1.0T
- Projector

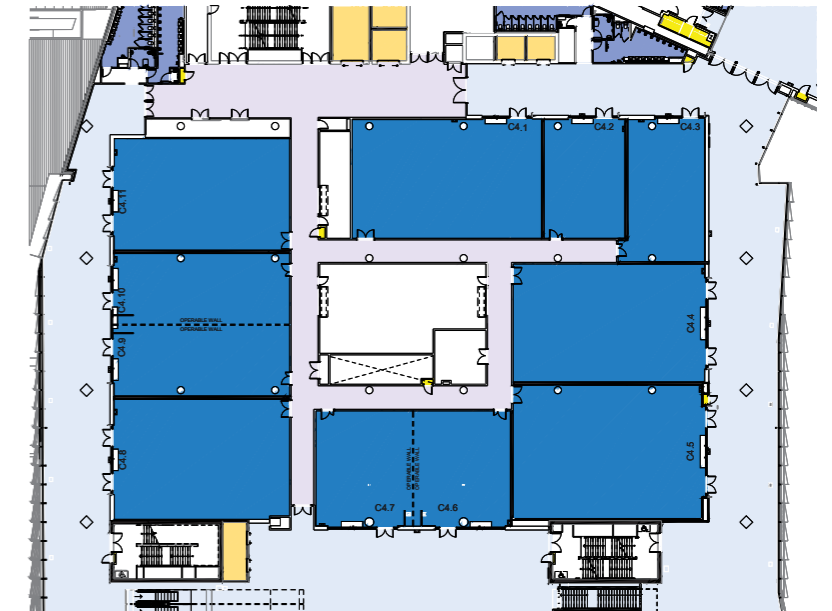
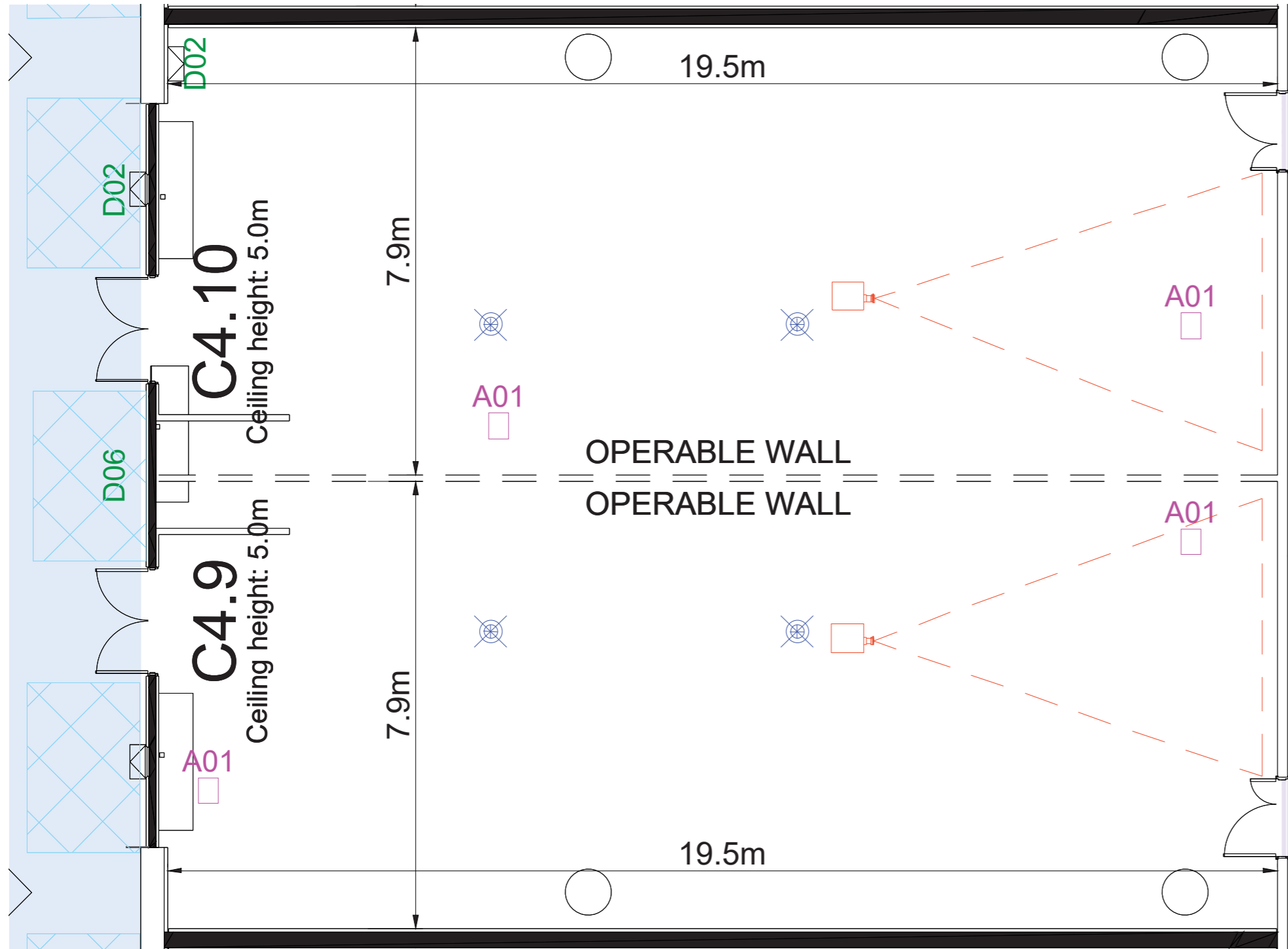

Level 4 Convention Centre

LEGEND

- Public Space Build Zone
- Circulation back of house
- Circulation front of house
- A01** Floor Box Type A01
6 x SGPO
2 x SINGLE DATA
- A07** Floor Box Type A07
2 x 15A SGPO
1 x 32A 3PH
2 x SINGLE DATA
- A09** Floor Box Type A09
2 x SGPO
1 x 20A SGPO
2 x SINGLE DATA
- A10** Floor Box Type A10
2 x SGPO
1 x 32A 3PH
2 x SINGLE DATA
- D02** Service Cupboard 02
2 x DGPO
1 x 32A 3PH
4 x SINGLE DATA
1 x 6C SMOF
- D04** Service Cupboard 04
2 x 15A SGPO
1 x 32A 3PH
2 x SINGLE DATA
- D05** Service Cupboard 05
1 x DGPO
1 x 32A 3PH
2 x SINGLE DATA
- D06** Service Cupboard 06
1 x DGPO
1 x 20A SGPO
2 x SINGLE DATA
- Rigging Point 1.0T
- Projector

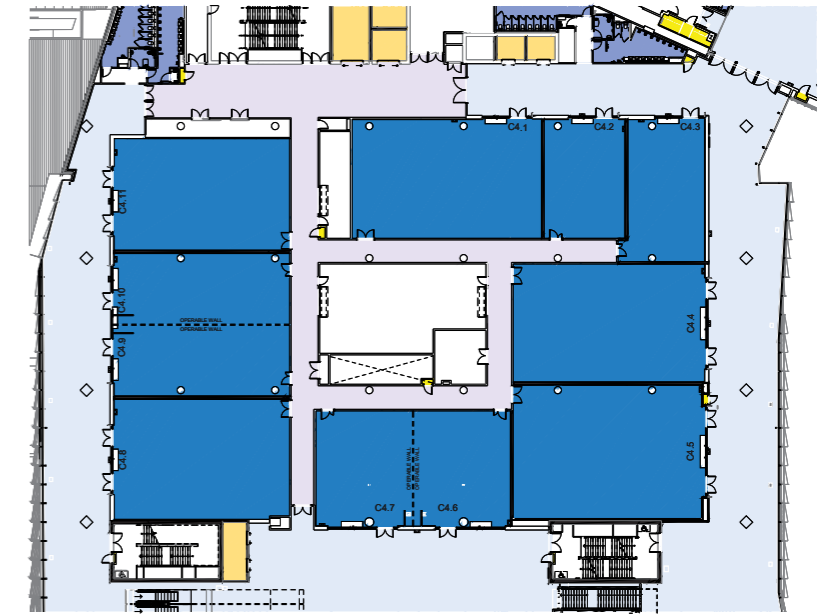
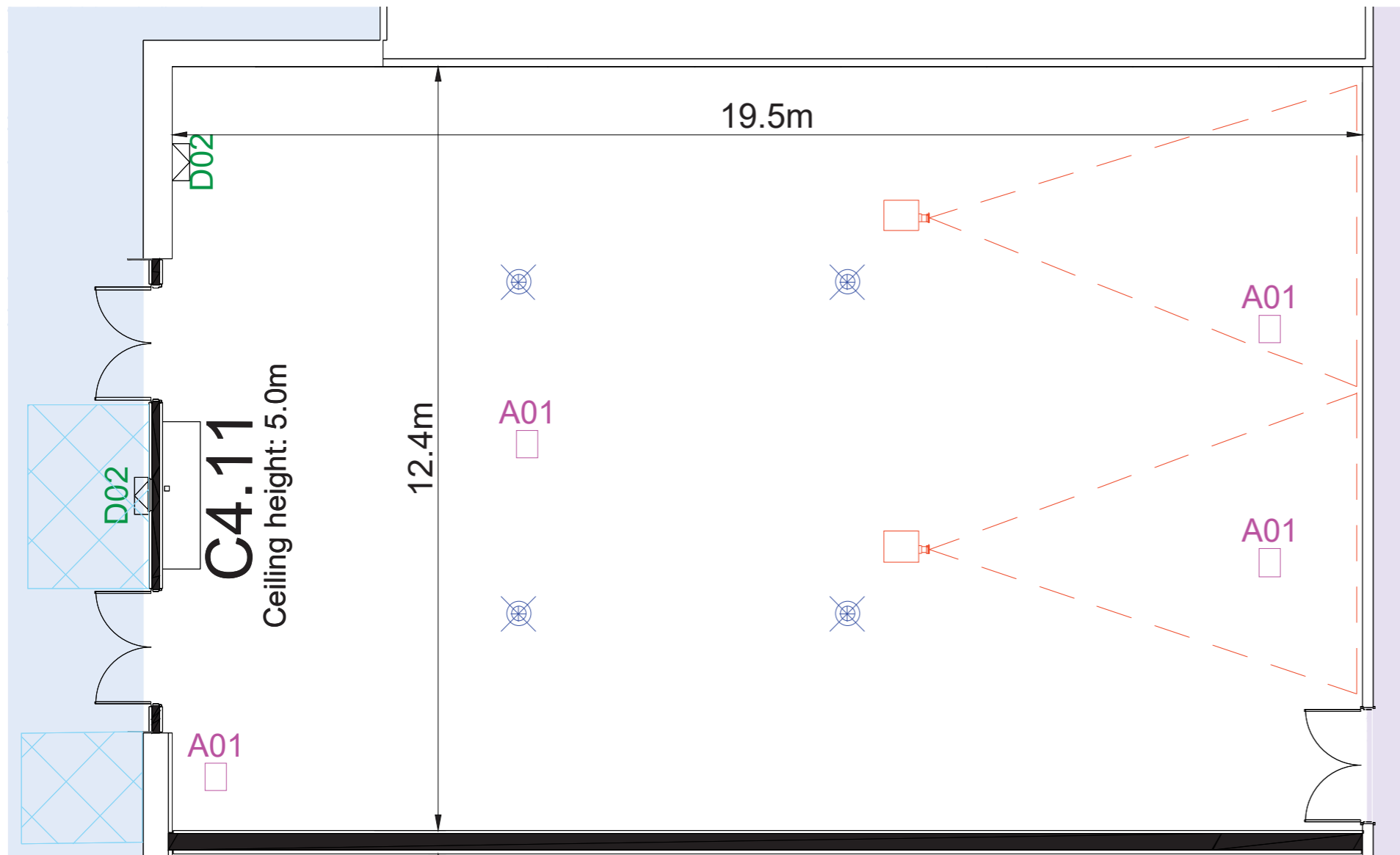

LEGEND

- Public Space Build Zone
- Floor Box Type A01
6 x SGPO
2 x SINGLE DATA
- Floor Box Type A07
2 x 15A SGPO
1 x 32A 3PH
2 x SINGLE DATA
- Floor Box Type A09
2 x SGPO
1 x 20A SGPO
2 x SINGLE DATA
- Floor Box Type A10
2 x SGPO
1 x 32A 3PH
2 x SINGLE DATA
- Service Cupboard 02
2 x DGPO
1 x 32A 3PH
4 x SINGLE DATA
1 x 6C SMOF
- Service Cupboard 04
2 x 15A SGPO
1 x 32A 3PH
2 x SINGLE DATA
- Service Cupboard 05
1 x DGPO
1 x 32A 3PH
2 x SINGLE DATA
- Service Cupboard 06
1 x DGPO
1 x 20A SGPO
2 x SINGLE DATA
- Rigging Point 1.0T
- Projector
- Circulation back of house
- Circulation front of house

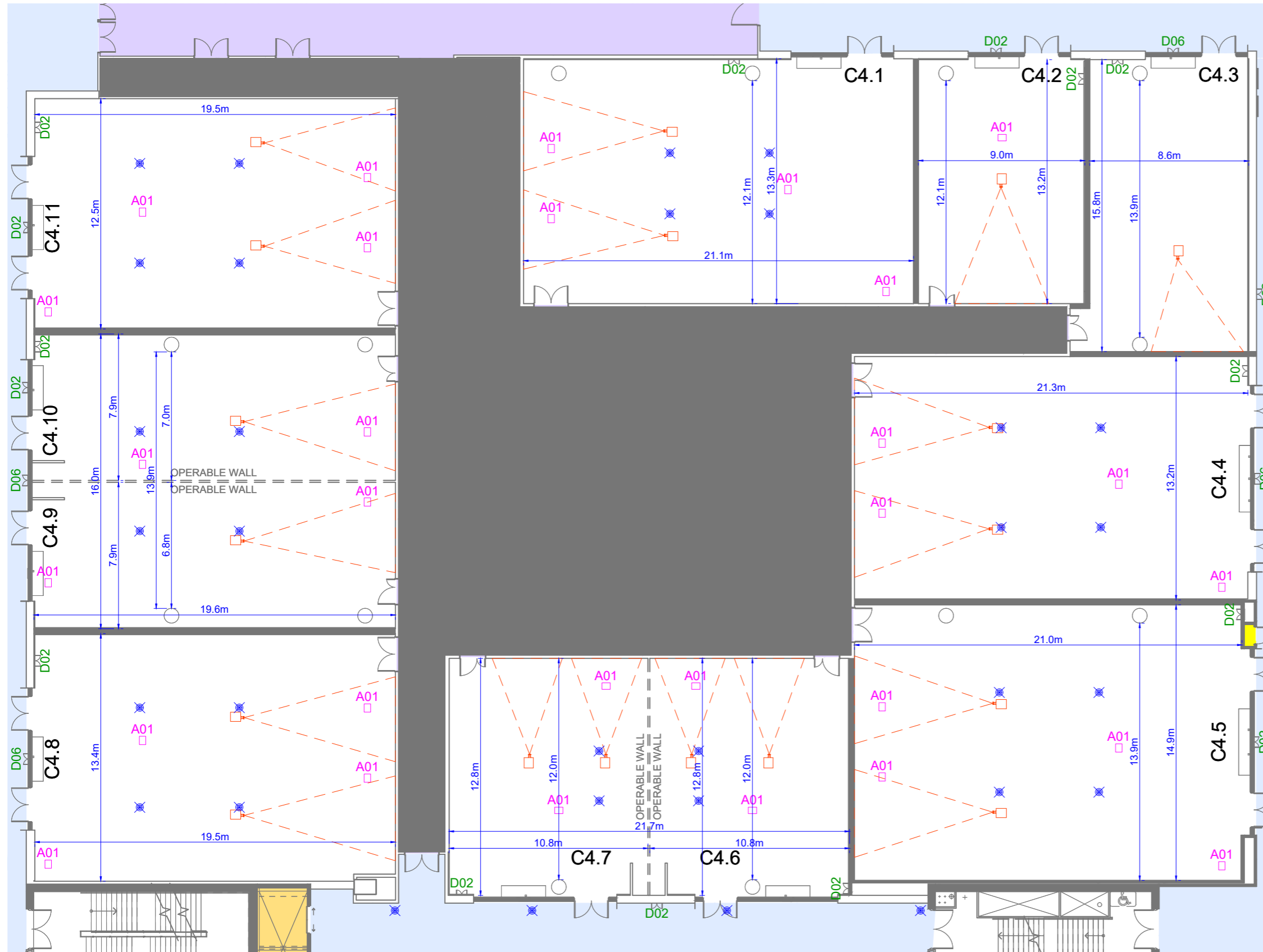

Axonometric cutaway view of Level 4 Convention Centre

- LEGEND**
- Back of House
 - Circulation Back of House
 - Circulation Front of House
 - Lifts
- LEGEND**
- A01 Floor Box Type A01
6 x SGPO
2 x SINGLE DATA
2 x SINGLE DATA SUPPLIED AND INSTALLED BY AV CONTRACTOR
 - A07 Floor Box Type A07
2 x 15A SGPO
1 x 32A 3PH
2 x SINGLE DATA
 - A09 Floor Box Type A09
2 x SGPO
1 x 20A SGPO
2 x SINGLE DATA
 - A10 Floor Box Type A10
2 x SGPO
1 x 32A 3PH
2 x SINGLE DATA
 - D02 Service Cupboard 02
2 x DGPO
1 x 32A 3PH
4 x SINGLE DATA
1 x 6C SMOF
 - D06 Service Cupboard 06
1 x DGPO
1 x 20A SGPO
2 x SINGLE DATA
 - Rigging Point 1.0T
 - Projector
 - Public Space Build Zone

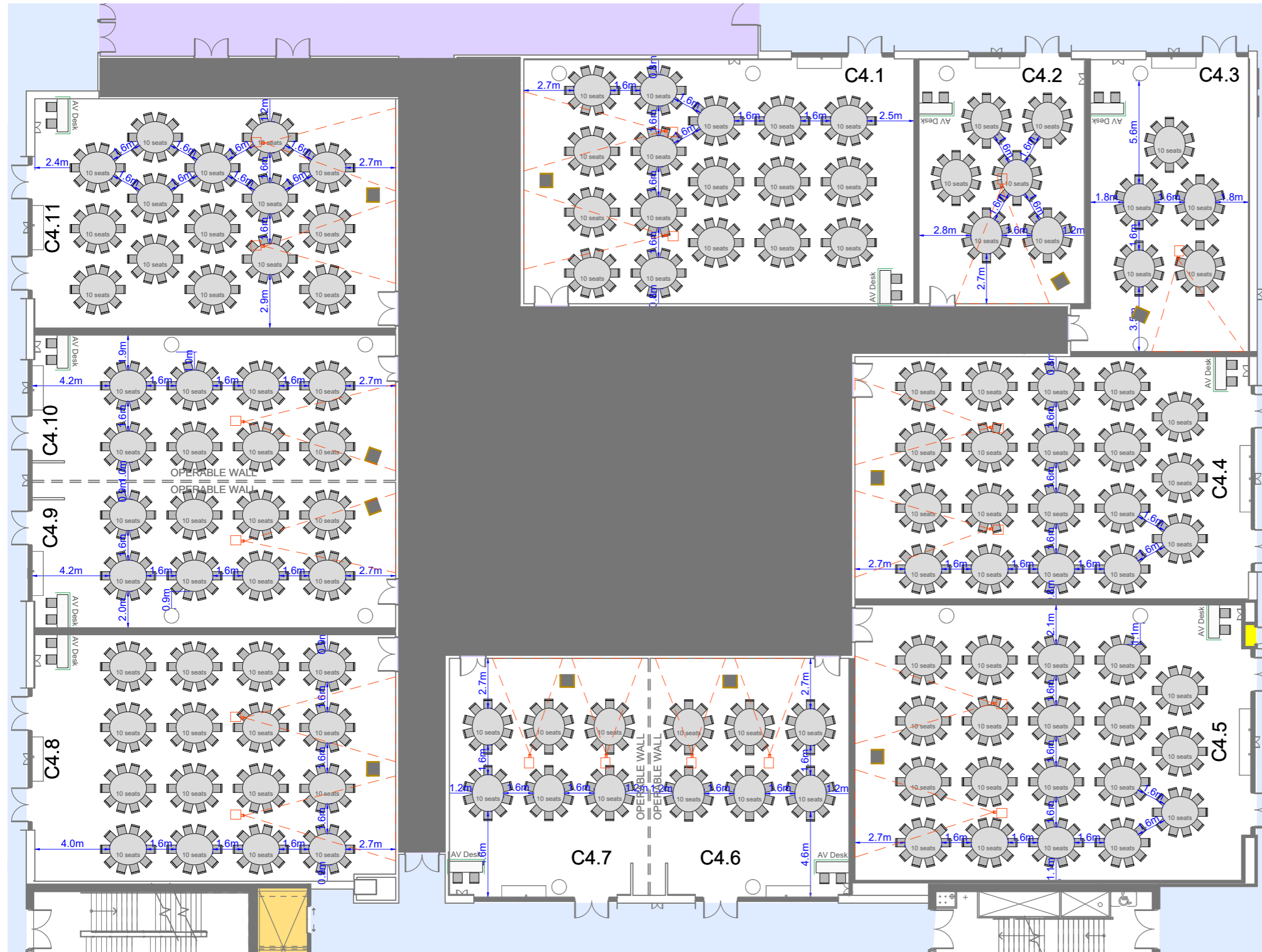

Axonometric cutaway view of Level 4 Convention Centre

ROOM NAME	BANQUET
MEETING ROOM C4.1	170
MEETING ROOM C4.2	60
MEETING ROOM C4.3	50
MEETING ROOM C4.4	190
MEETING ROOM C4.5	190
MEETING ROOM C4.6	60
MEETING ROOM C4.7	60
MEETING ROOM C4.6 & C4.7	120
MEETING ROOM C4.8	160
MEETING ROOM C4.9	80
MEETING ROOM C4.10	80
MEETING ROOM C4.9 & C4.10	160
MEETING ROOM C4.11	150

* Standard capacity illustrated. Higher capacities can be achieved with less staging and AV services and reduced furniture spacing. Please consider your event requirements when viewing capacities.

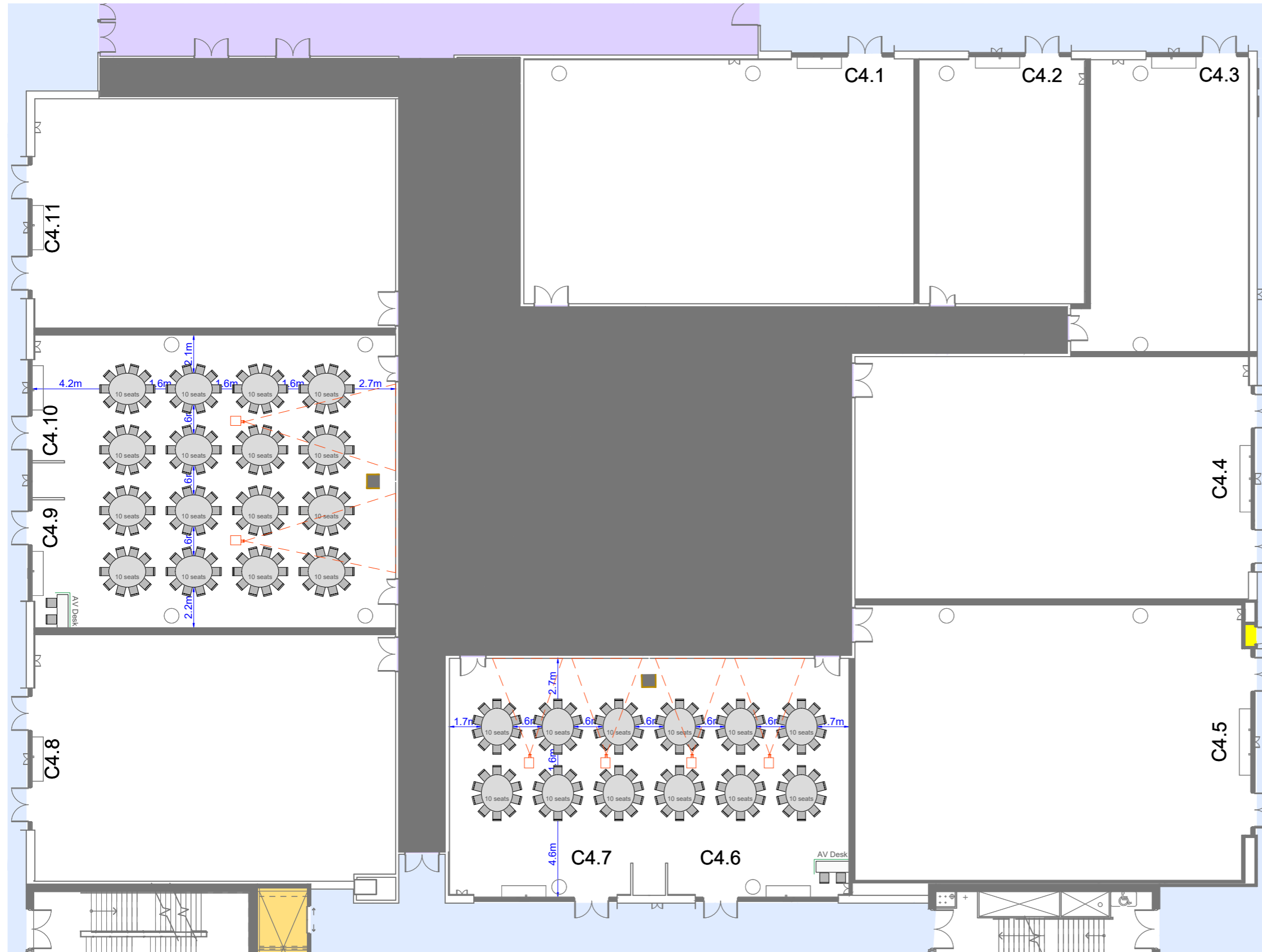

Axonometric cutaway view of Level 4 Convention Centre

ROOM NAME	BANQUET
MEETING ROOM C4.1	170
MEETING ROOM C4.2	60
MEETING ROOM C4.3	50
MEETING ROOM C4.4	190
MEETING ROOM C4.5	190
MEETING ROOM C4.6	60
MEETING ROOM C4.7	60
MEETING ROOM C4.6 & C4.7	120
MEETING ROOM C4.8	160
MEETING ROOM C4.9	80
MEETING ROOM C4.10	80
MEETING ROOM C4.9 & C4.10	160
MEETING ROOM C4.11	150

* Standard capacity illustrated. Higher capacities can be achieved with less staging and AV services and reduced furniture spacing. Please consider your event requirements when viewing capacities.

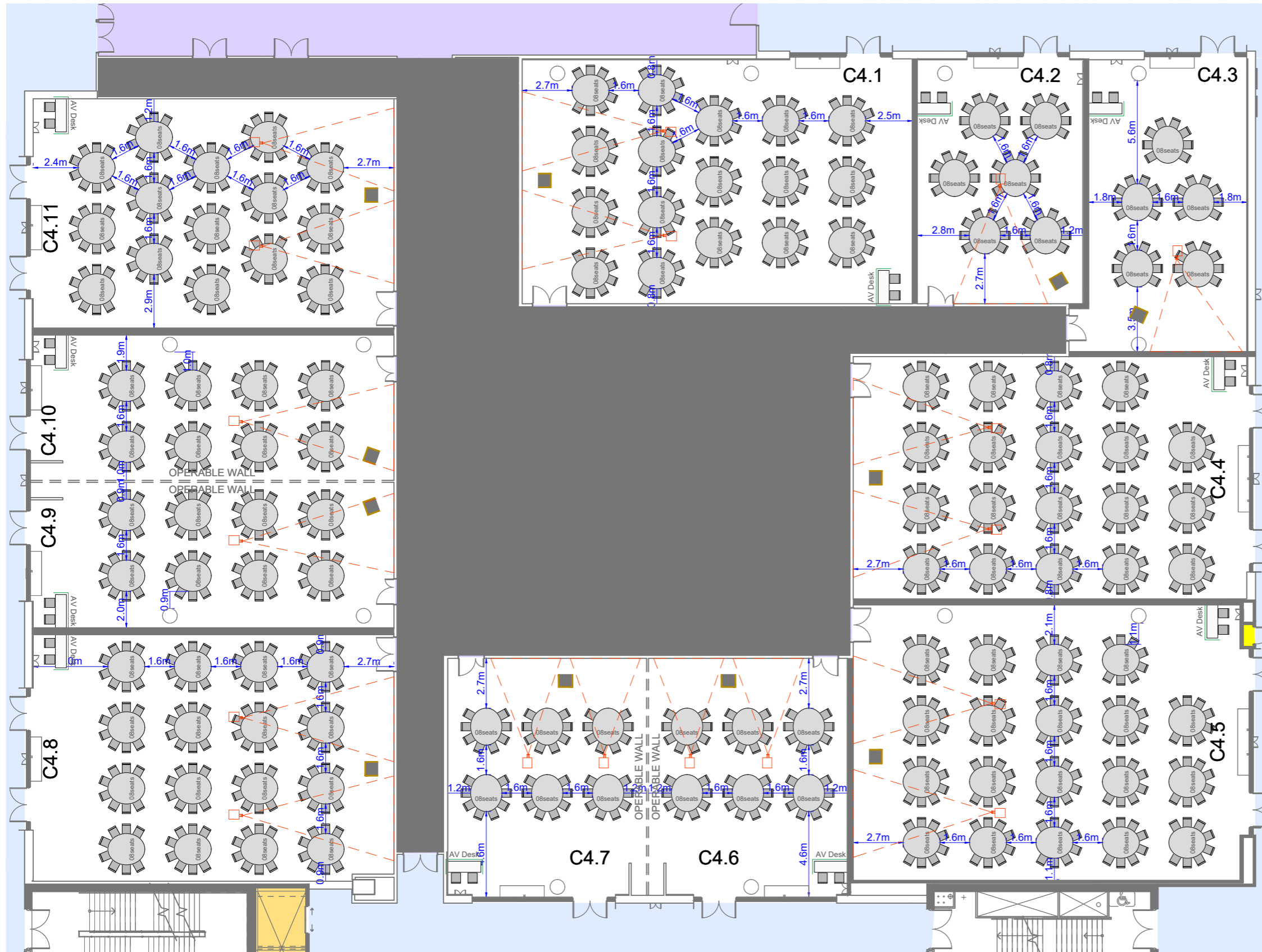

Axonometric cutaway view of Level 4 Convention Centre

ROOM NAME	CABARET
MEETING ROOM C4.1	136
MEETING ROOM C4.2	48
MEETING ROOM C4.3	40
MEETING ROOM C4.4	152
MEETING ROOM C4.5	152
MEETING ROOM C4.6	48
MEETING ROOM C4.7	48
MEETING ROOM C4.6 & C4.7	96
MEETING ROOM C4.8	128
MEETING ROOM C4.9	64
MEETING ROOM C4.10	64
MEETING ROOM C4.9 & C4.10	128
MEETING ROOM C4.11	120

* Standard capacity illustrated. Higher capacities can be achieved with less staging and AV services and reduced furniture spacing. Please consider your event requirements when viewing capacities.



Axonometric cutaway view of Level 4 Convention Centre

ROOM NAME	CABARET
MEETING ROOM C4.1	136
MEETING ROOM C4.2	48
MEETING ROOM C4.3	40
MEETING ROOM C4.4	152
MEETING ROOM C4.5	152
MEETING ROOM C4.6	48
MEETING ROOM C4.7	48
MEETING ROOM C4.6 & C4.7	96
MEETING ROOM C4.8	128
MEETING ROOM C4.9	64
MEETING ROOM C4.10	64
MEETING ROOM C4.9 & C4.10	128
MEETING ROOM C4.11	120

* Standard capacity illustrated. Higher capacities can be achieved with less staging and AV services and reduced furniture spacing. Please consider your event requirements when viewing capacities.

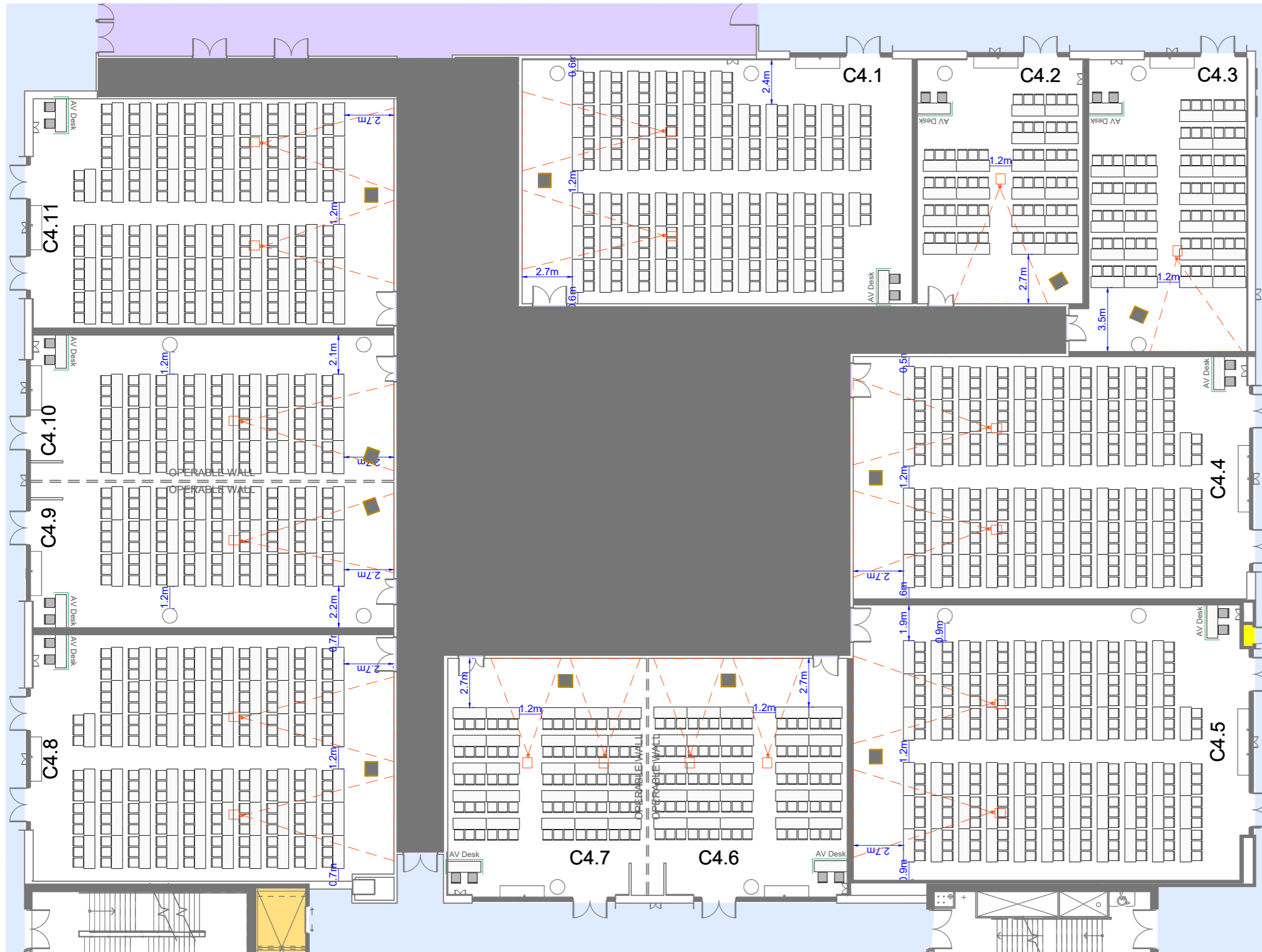

Axonometric cutaway view of Level 4 Convention Centre

ROOM NAME	CLASSROOM
MEETING ROOM C4.1	177
MEETING ROOM C4.2	60
MEETING ROOM C4.3	72
MEETING ROOM C4.4	192
MEETING ROOM C4.5	192
MEETING ROOM C4.6	75
MEETING ROOM C4.7	75
MEETING ROOM C4.6 & C4.7	150
MEETING ROOM C4.8	174
MEETING ROOM C4.9	81
MEETING ROOM C4.10	81
MEETING ROOM C4.9 & C4.10	177
MEETING ROOM C4.11	174

* Standard capacity illustrated. Higher capacities can be achieved with less staging and AV services and reduced furniture spacing. Please consider your event requirements when viewing capacities.



Axonometric cutaway view of Level 4 Convention Centre

ROOM NAME	CLASSROOM
MEETING ROOM C4.1	177
MEETING ROOM C4.2	60
MEETING ROOM C4.3	72
MEETING ROOM C4.4	192
MEETING ROOM C4.5	192
MEETING ROOM C4.6	75
MEETING ROOM C4.7	75
MEETING ROOM C4.6 & C4.7	150
MEETING ROOM C4.8	174
MEETING ROOM C4.9	81
MEETING ROOM C4.10	81
MEETING ROOM C4.9 & C4.10	177
MEETING ROOM C4.11	174

* Standard capacity illustrated. Higher capacities can be achieved with less staging and AV services and reduced furniture spacing. Please consider your event requirements when viewing capacities.



Axonometric cutaway view of Level 4 Convention Centre

ROOM NAME	THEATRE
MEETING ROOM C4.1	275
MEETING ROOM C4.2	106
MEETING ROOM C4.3	126
MEETING ROOM C4.4	331
MEETING ROOM C4.5	351
MEETING ROOM C4.6	124
MEETING ROOM C4.7	124
MEETING ROOM C4.6 & C4.7	260
MEETING ROOM C4.8	289
MEETING ROOM C4.9	166
MEETING ROOM C4.10	166
MEETING ROOM C4.9 & C4.10	323
MEETING ROOM C4.11	261

* Standard capacity illustrated. Higher capacities can be achieved with less staging and AV services and reduced furniture spacing. Please consider your event requirements when viewing capacities.

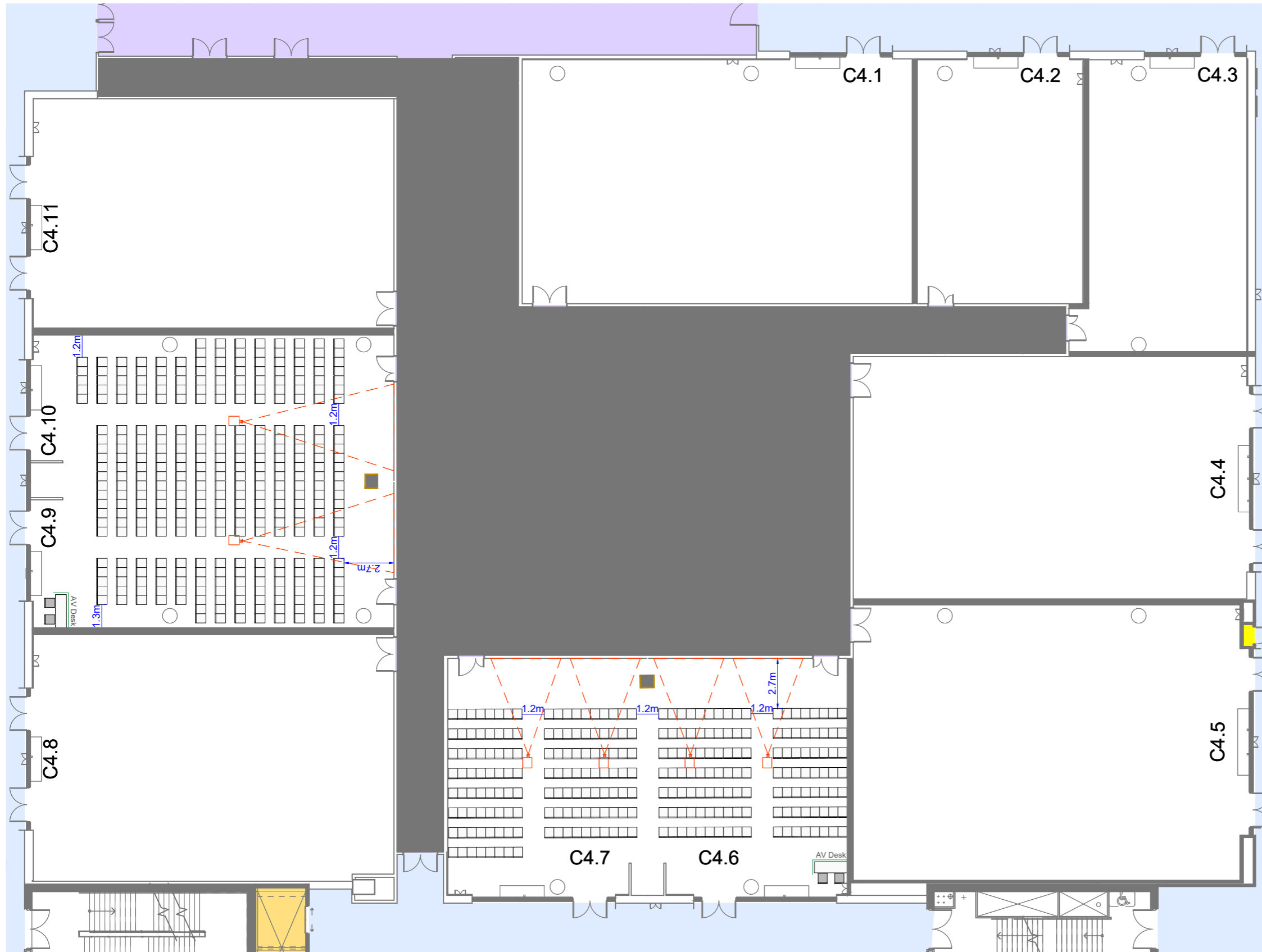

Axonometric cutaway view of Level 4 Convention Centre

ROOM NAME	THEATRE
MEETING ROOM C4.1	275
MEETING ROOM C4.2	106
MEETING ROOM C4.3	126
MEETING ROOM C4.4	331
MEETING ROOM C4.5	351
MEETING ROOM C4.6	124
MEETING ROOM C4.7	124
MEETING ROOM C4.6 & C4.7	260
MEETING ROOM C4.8	289
MEETING ROOM C4.9	166
MEETING ROOM C4.10	166
MEETING ROOM C4.9 & C4.10	323
MEETING ROOM C4.11	261

* Standard capacity illustrated. Higher capacities can be achieved with less staging and AV services and reduced furniture spacing. Please consider your event requirements when viewing capacities.

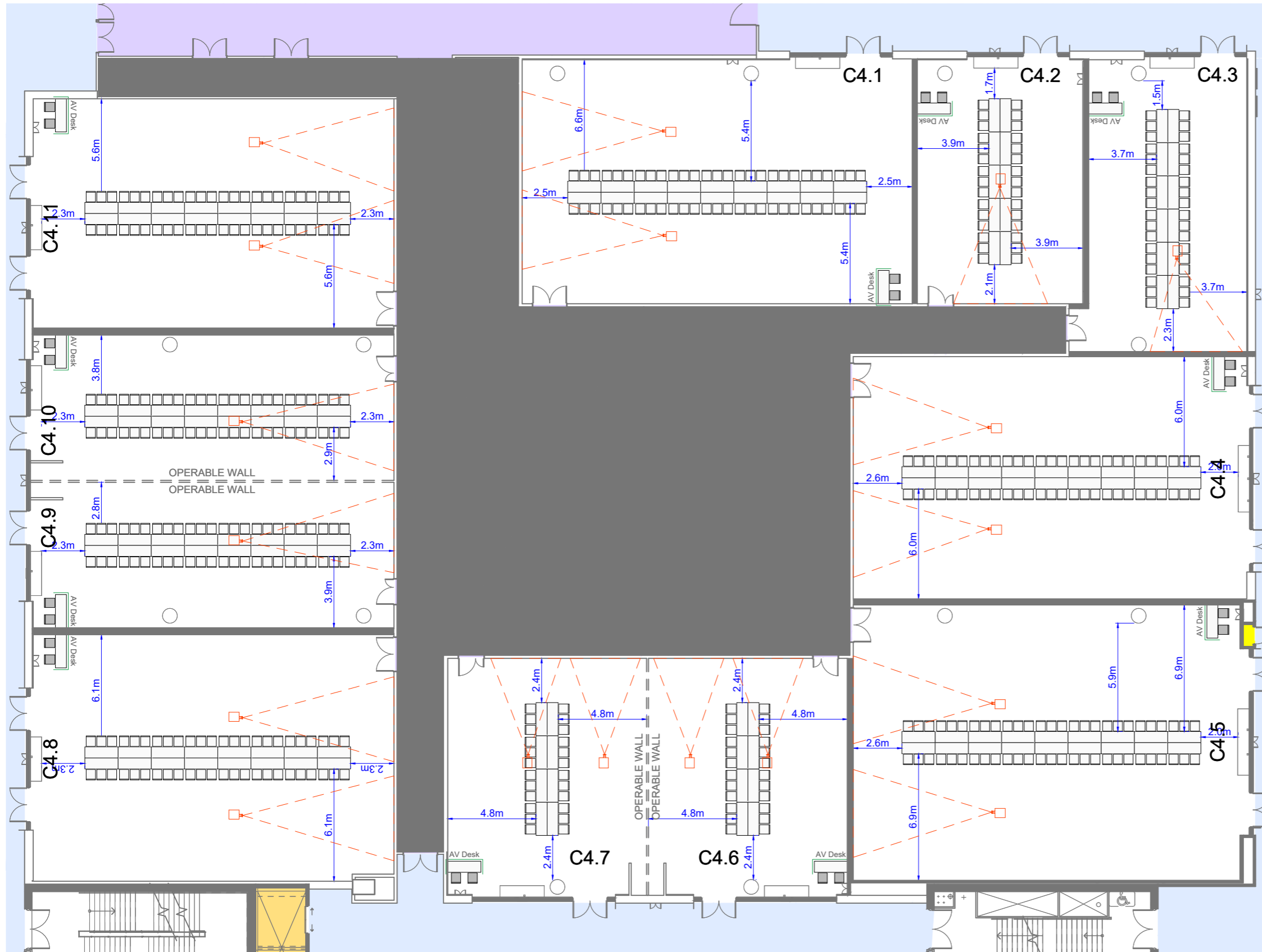

Axonometric cutaway view of Level 4 Convention Centre

ROOM NAME	BOARDROOM
MEETING ROOM C4.1	54
MEETING ROOM C4.2	30
MEETING ROOM C4.3	36
MEETING ROOM C4.4	54
MEETING ROOM C4.5	54
MEETING ROOM C4.6	24
MEETING ROOM C4.7	24
MEETING ROOM C4.6 & C4.7	54
MEETING ROOM C4.8	48
MEETING ROOM C4.9	48
MEETING ROOM C4.10	48
MEETING ROOM C4.9 & C4.10	42
MEETING ROOM C4.11	48

* Standard capacity illustrated. Higher capacities can be achieved with less staging and AV services and reduced furniture spacing. Please consider your event requirements when viewing capacities.

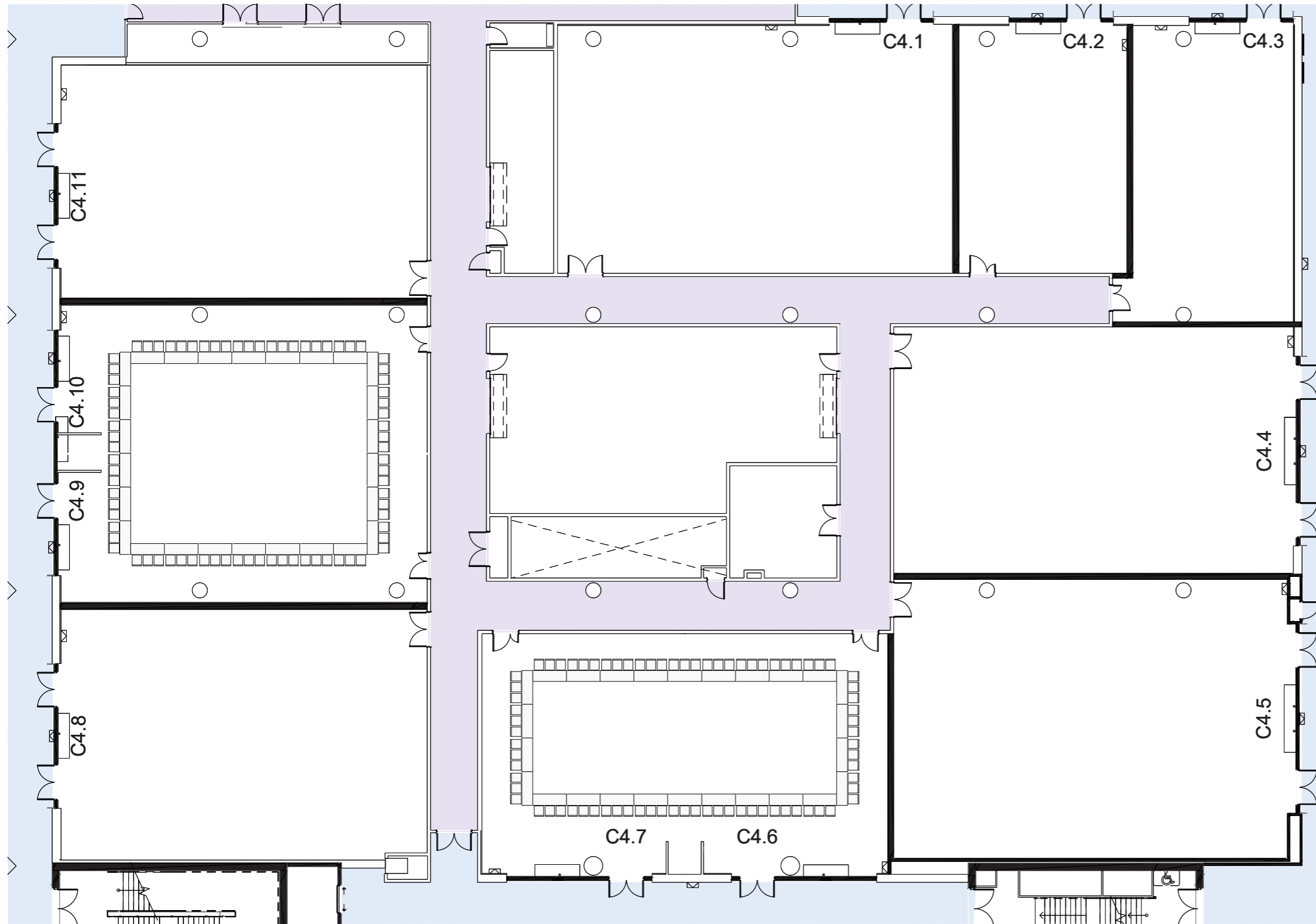

Axonometric cutaway view of Level 4 Convention Centre

ROOM NAME	BOARDROOM
	MAXIMUM
MEETING ROOM C4.1	79
MEETING ROOM C4.2	42
MEETING ROOM C4.3	48
MEETING ROOM C4.4	78
MEETING ROOM C4.5	84
MEETING ROOM C4.6	42
MEETING ROOM C4.7	42
MEETING ROOMS C4.6 & C4.7	78
MEETING ROOM C4.8	72
MEETING ROOM C4.9	48
MEETING ROOM C4.10	48
MEETING ROOMS C4.9 & C4.10	78
MEETING ROOM C4.11	72

* Standard capacity illustrated. Higher capacities can be achieved with less staging and AV services and reduced furniture spacing. Please consider your event requirements when viewing capacities.

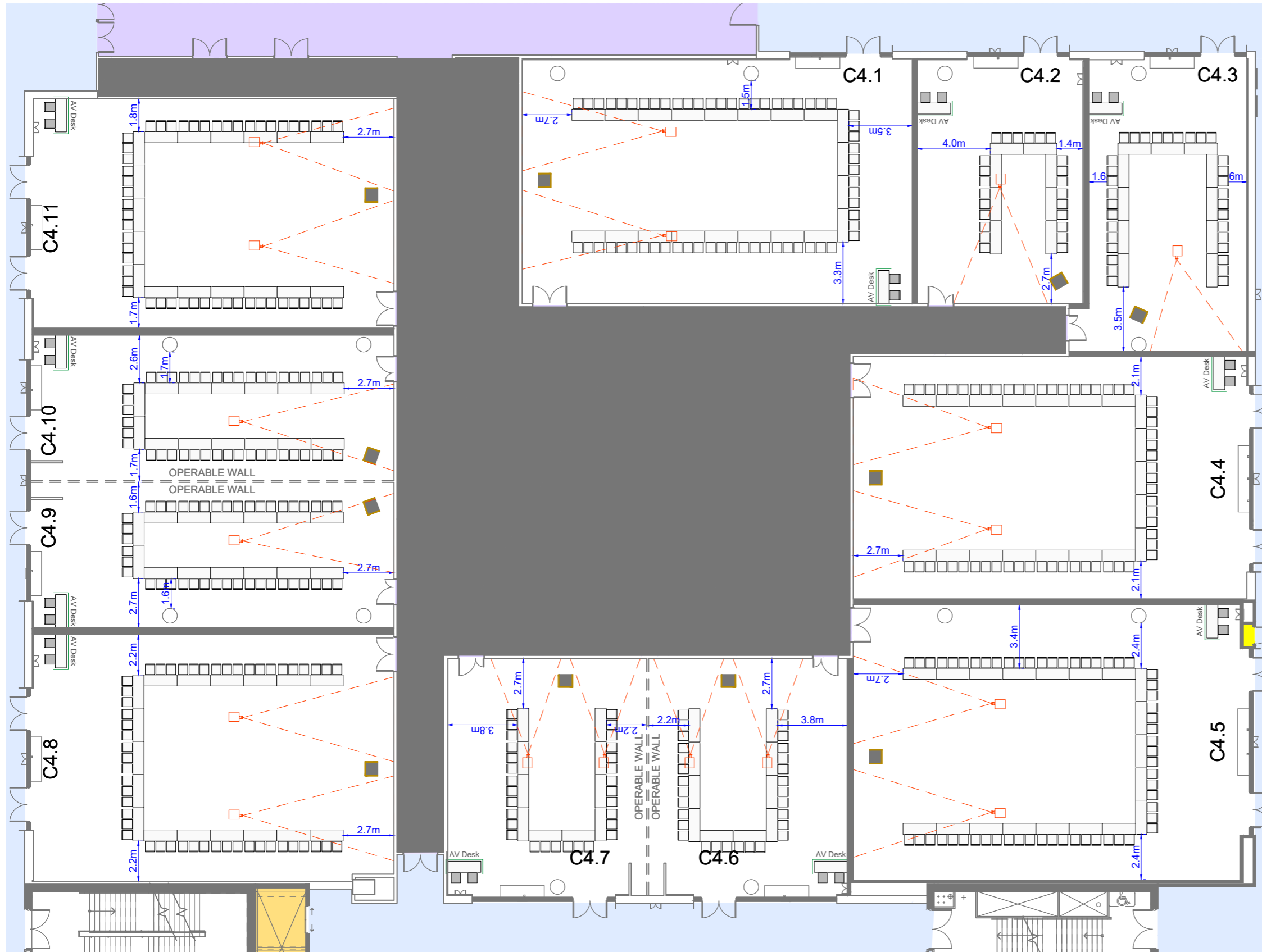

Axonometric cutaway view of Level 4 Convention Centre

ROOM NAME	U SHAPE
MEETING ROOM C4.1	60
MEETING ROOM C4.2	24
MEETING ROOM C4.3	33
MEETING ROOM C4.4	57
MEETING ROOM C4.5	57
MEETING ROOM C4.6	30
MEETING ROOM C4.7	30
MEETING ROOM C4.6 & C4.7	48
MEETING ROOM C4.8	51
MEETING ROOM C4.9	42
MEETING ROOM C4.10	42
MEETING ROOM C4.9 & C4.10	54
MEETING ROOM C4.11	51

* Standard capacity illustrated. Higher capacities can be achieved with less staging and AV services and reduced furniture spacing. Please consider your event requirements when viewing capacities.

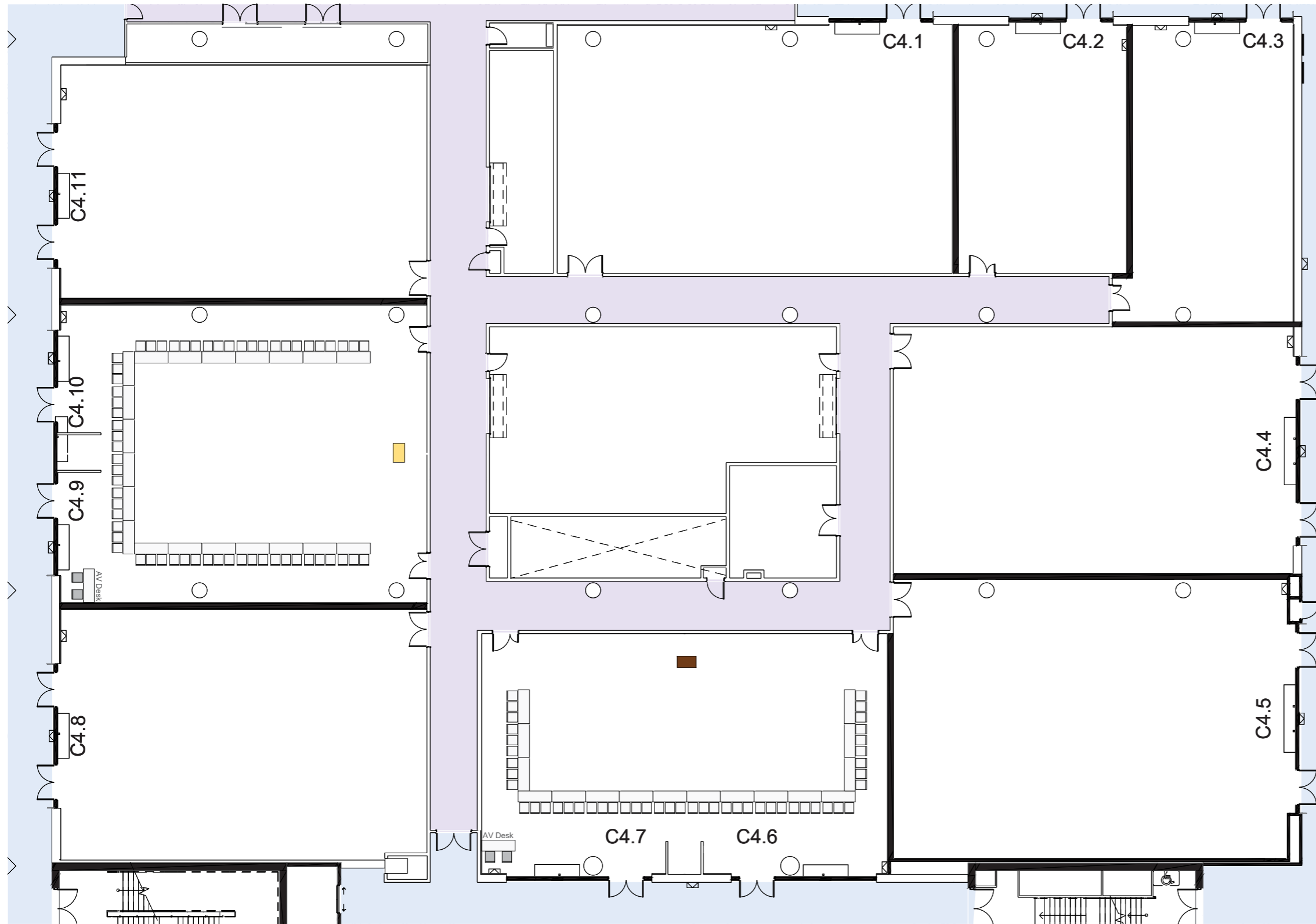

Axonometric cutaway view of Level 4 Convention Centre

ROOM NAME	U SHAPE
	MAXIMUM
MEETING ROOM C4.1	61
MEETING ROOM C4.2	24
MEETING ROOM C4.3	33
MEETING ROOM C4.4	63
MEETING ROOM C4.5	63
MEETING ROOM C4.6	30
MEETING ROOM C4.7	30
MEETING ROOMS C4.6 & C4.7	48
MEETING ROOM C4.8	57
MEETING ROOM C4.9	42
MEETING ROOM C4.10	42
MEETING ROOMS C4.9 & C4.10	60
MEETING ROOM C4.11	57

* Standard capacity illustrated. Higher capacities can be achieved with less staging and AV services and reduced furniture spacing. Please consider your event requirements when viewing capacities.

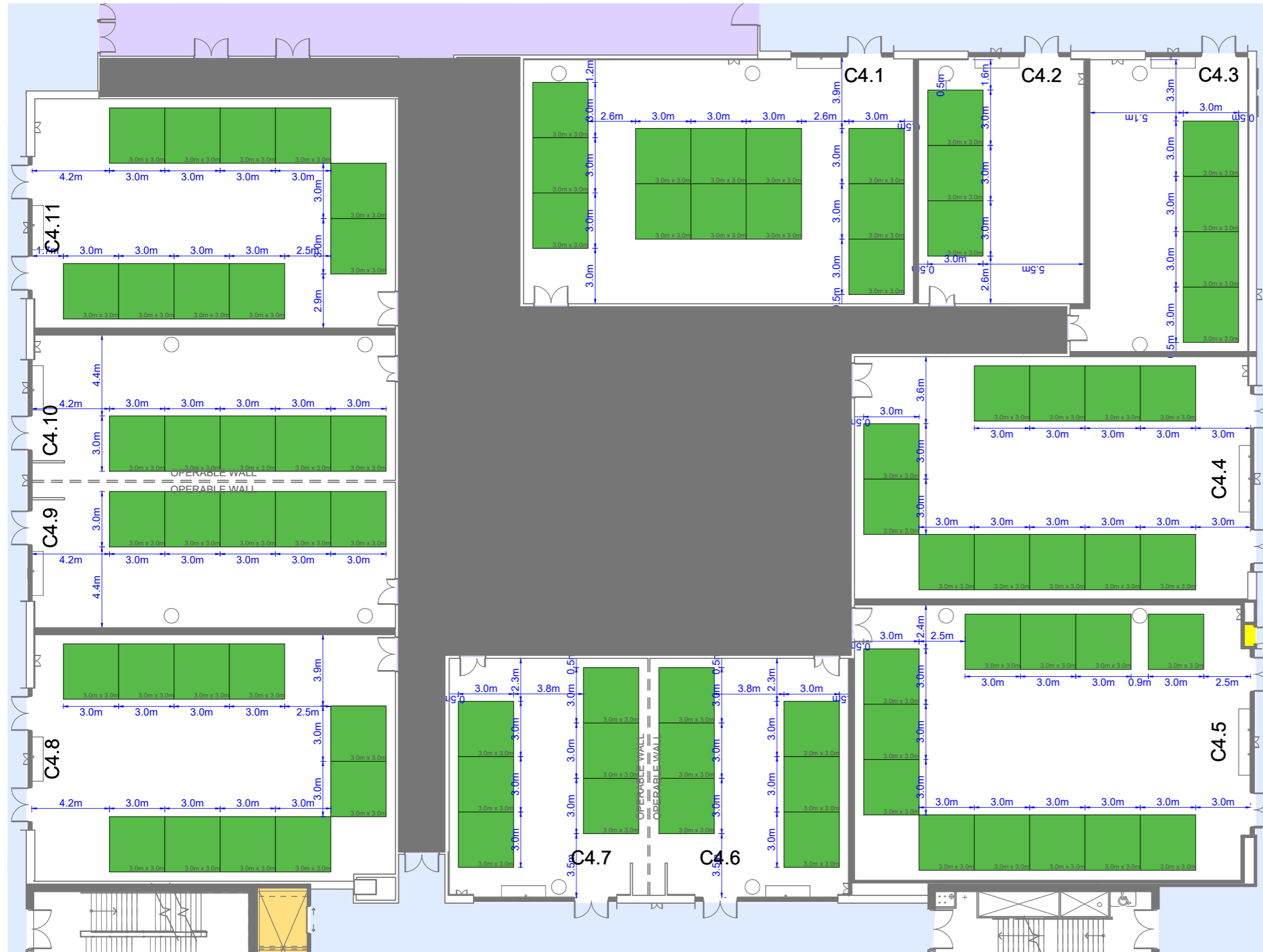

Axonometric cutaway view of Level 4 Convention Centre

ROOM NAME	EXHIBITION 3m x 3m
MEETING ROOM C4.1	12
MEETING ROOM C4.2	3
MEETING ROOM C4.3	4
MEETING ROOM C4.4	11
MEETING ROOM C4.5	12
MEETING ROOM C4.6	6
MEETING ROOM C4.7	6
MEETING ROOM C4.6 & C4.7	10
MEETING ROOM C4.8	10
MEETING ROOM C4.9	5
MEETING ROOM C4.10	5
MEETING ROOM C4.9 & C4.10	12
MEETING ROOM C4.11	10

* Standard capacity illustrated. Higher capacities can be achieved with less staging and AV services and reduced furniture spacing. Please consider your event requirements when viewing capacities.



Axonometric cutaway view of Level 4 Convention Centre

ROOM NAME	EXHIBITION 3m x 3m
MEETING ROOM C4.1	12
MEETING ROOM C4.2	3
MEETING ROOM C4.3	4
MEETING ROOM C4.4	11
MEETING ROOM C4.5	12
MEETING ROOM C4.6	6
MEETING ROOM C4.7	6
MEETING ROOM C4.6 & C4.7	10
MEETING ROOM C4.8	10
MEETING ROOM C4.9	5
MEETING ROOM C4.10	5
MEETING ROOM C4.9 & C4.10	12
MEETING ROOM C4.11	10

* Standard capacity illustrated. Higher capacities can be achieved with less staging and AV services and reduced furniture spacing. Please consider your event requirements when viewing capacities.

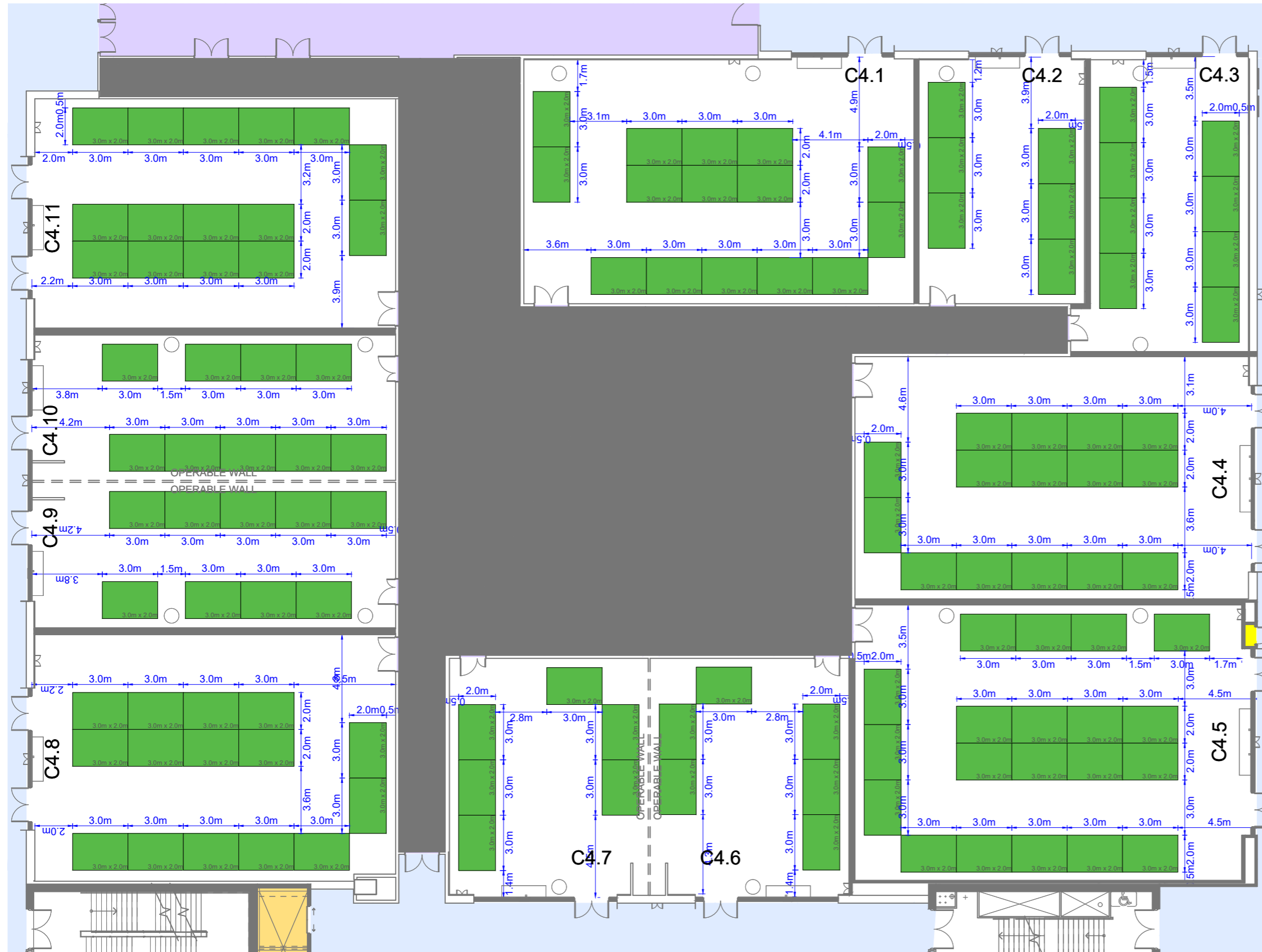

Axonometric cutaway view of Level 4 Convention Centre

ROOM NAME	EXHIBITION 3m x 2m
MEETING ROOM C4.1	15
MEETING ROOM C4.2	6
MEETING ROOM C4.3	8
MEETING ROOM C4.4	15
MEETING ROOM C4.5	20
MEETING ROOM C4.6	6
MEETING ROOM C4.7	6
MEETING ROOM C4.6 & C4.7	14
MEETING ROOM C4.8	15
MEETING ROOM C4.9	9
MEETING ROOM C4.10	9
MEETING ROOM C4.9 & C4.10	16
MEETING ROOM C4.11	15

* Standard capacity illustrated. Higher capacities can be achieved with less staging and AV services and reduced furniture spacing. Please consider your event requirements when viewing capacities.



Axonometric cutaway view of Level 4 Convention Centre

ROOM NAME	EXHIBITION 3m x 2m
MEETING ROOM C4.1	15
MEETING ROOM C4.2	6
MEETING ROOM C4.3	8
MEETING ROOM C4.4	15
MEETING ROOM C4.5	20
MEETING ROOM C4.6	6
MEETING ROOM C4.7	6
MEETING ROOM C4.6 & C4.7	14
MEETING ROOM C4.8	15
MEETING ROOM C4.9	9
MEETING ROOM C4.10	9
MEETING ROOM C4.9 & C4.10	16
MEETING ROOM C4.11	15

* Standard capacity illustrated. Higher capacities can be achieved with less staging and AV services and reduced furniture spacing. Please consider your event requirements when viewing capacities.

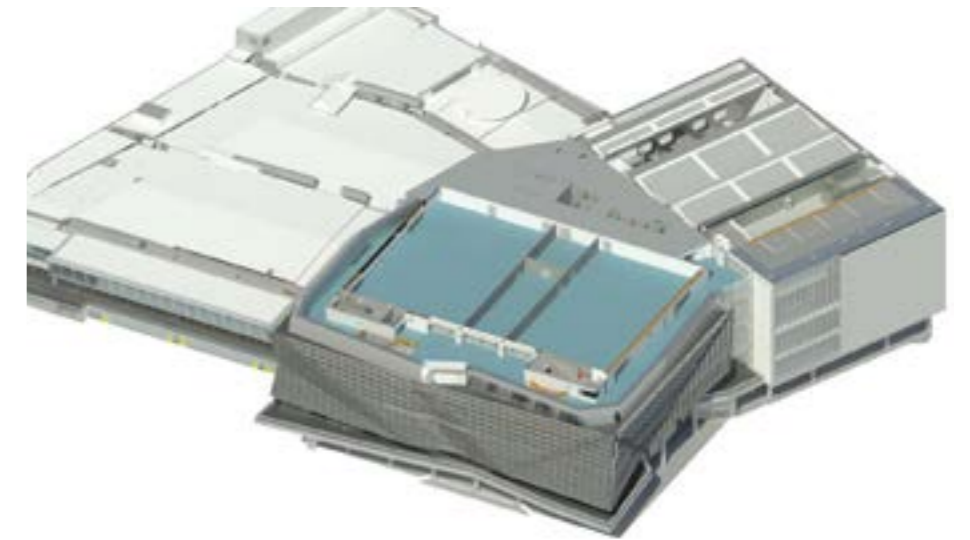
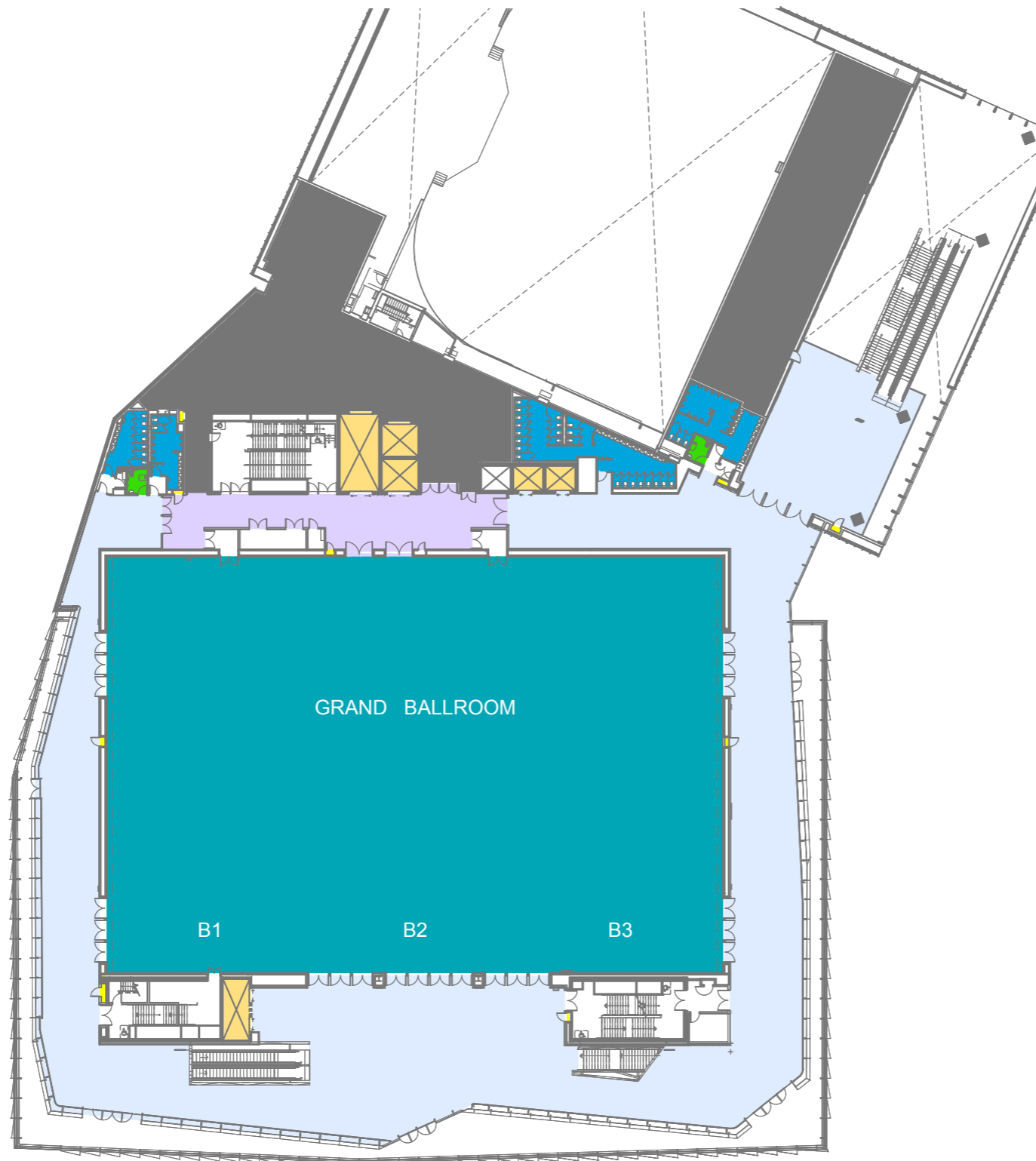

Axonometric cutaway view of Level 5 Convention Centre

LEGEND

- Back of House
- Circulation Back of House
- Circulation Front of House
- Lifts
- Fire Hydrants
- Toilets / Facilities
- Accessible Toilet

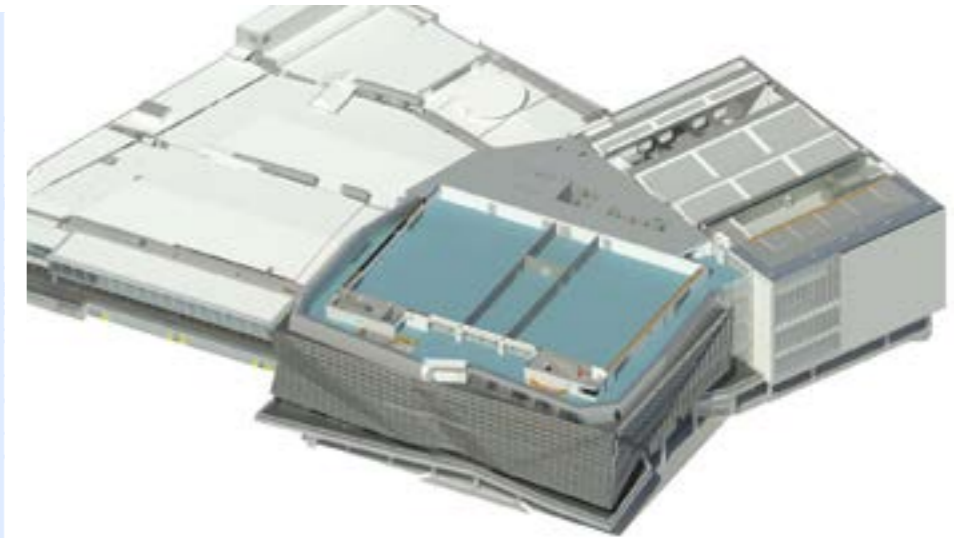
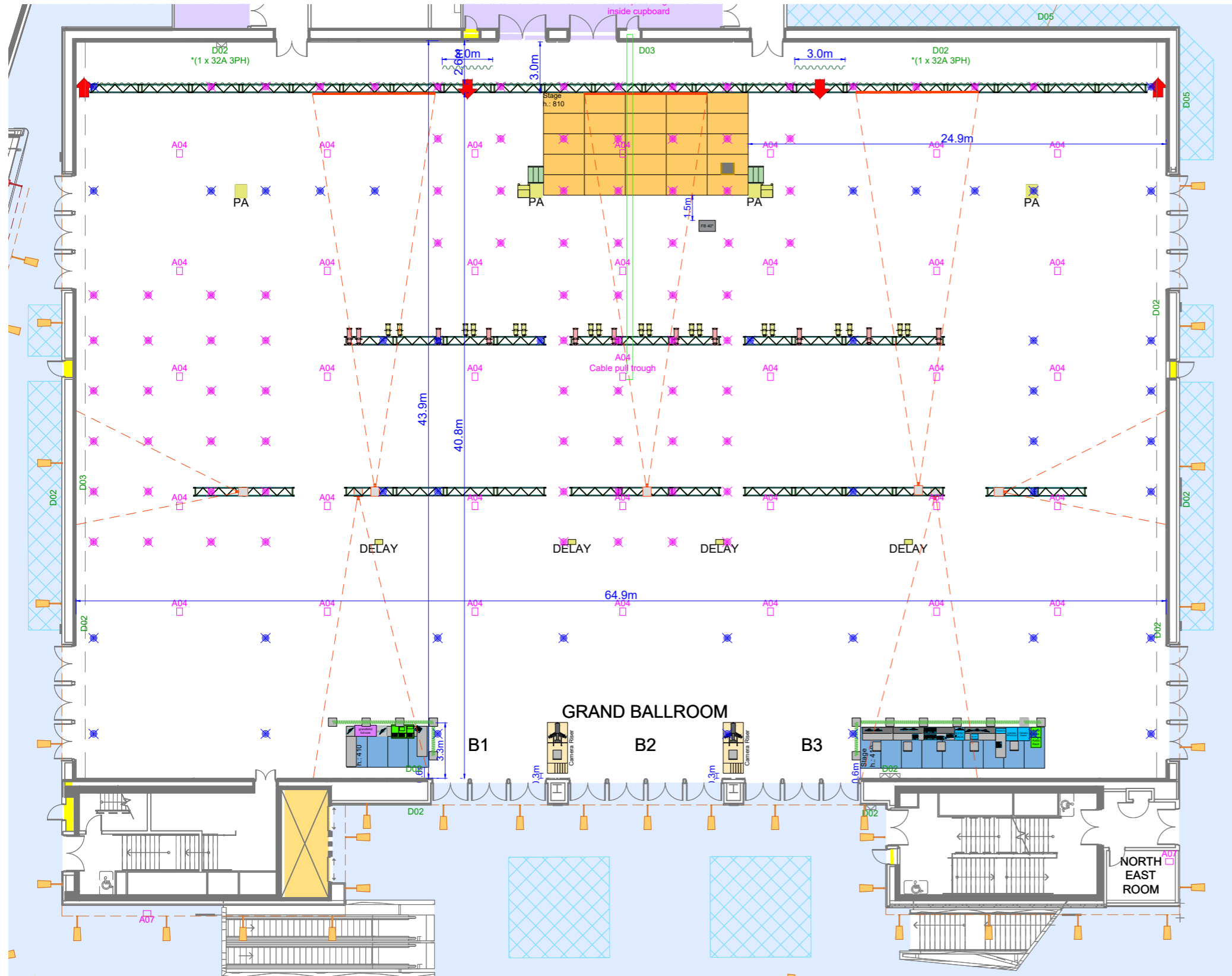

Axonometric cutaway view of Level 5 Convention Centre

Legend

- A04 Floor Box Type A04
3 x SGPO
2 x SINGLE DATA
- A07 Floor Box Type A07
2 x 15A SGPO
1 x 32A 3PH
2 x SINGLE DATA
- A09 Floor Box Type A09
2 x SGPO
1 x 20A SGPO
2 x SINGLE DATA
- A10 Floor Box Type A10
2 x SGPO
1 x 32A 3PH
2 x SINGLE DATA
- D02 Service Cupboard 02
2 x DGPO
1 x 32A 3PH
4 x SINGLE DATA
1 x 6C SMOF
- D03 Service Cupboard 03
2 x DGPO
1 x 32A 3PH
1 x 200A 3PH
4 x SINGLE DATA
1 x 6C SMOF
- D05 Service Cupboard 05
1 x DGPO
1 x 32A 3PH
2 x SINGLE DATA
- ✕ Rigging Point 1.0T
- ✕ Rigging Point 2.5T
- Projector
- Internal Up Lighting (Coloured)

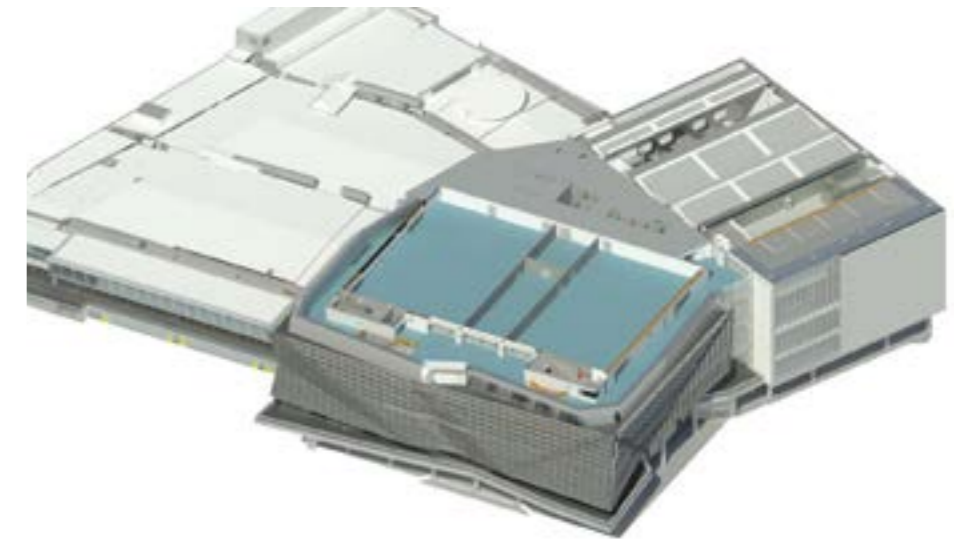
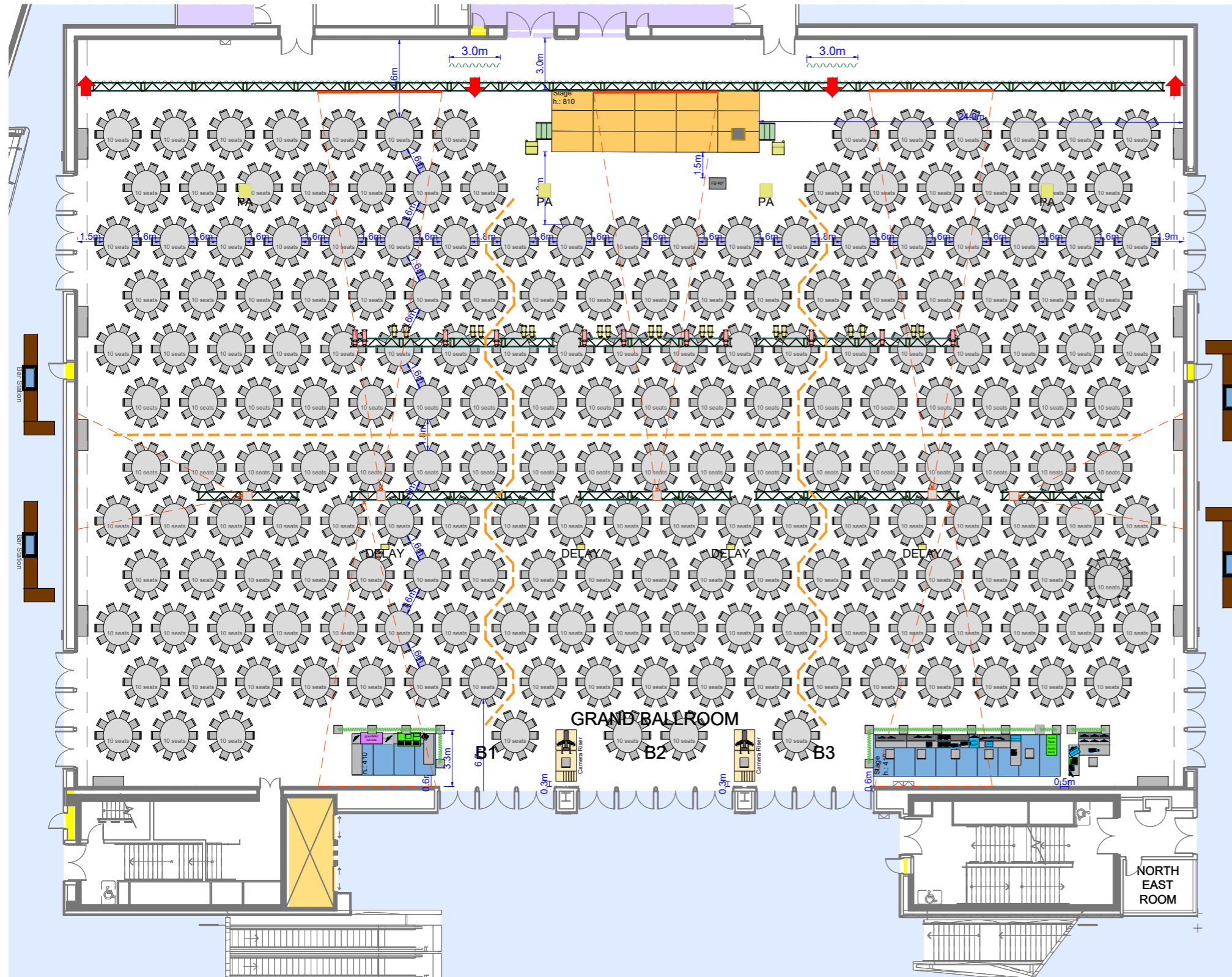

Axonometric cutaway view of Level 5 Convention Centre

ROOM NAME	BANQUET
GRAND BALLROOM	2000
GRAND BALLROOM B1	620
GRAND BALLROOM B2	NA
GRAND BALLROOM B3	530
GRAND BALLROOM MODE1	890
GRAND BALLROOM B1 + B2	890
GRAND BALLROOM B2 + B3	800

* Standard Capacity illustrated. Higher capacities can be achieved with less staging and AV services and reduced furniture spacing. Please consider your event requirements when viewing capacities

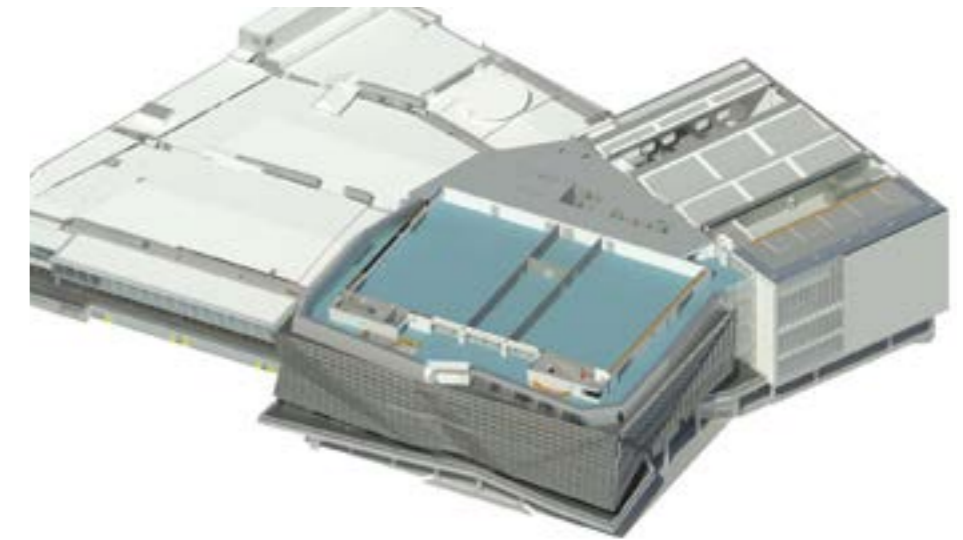

Axonometric cutaway view of Level 5 Convention Centre

ROOM NAME	BANQUET
GRAND BALLROOM	2000
GRAND BALLROOM B1	620
GRAND BALLROOM B2	NA
GRAND BALLROOM B3	530
GRAND BALLROOM MODE1	890
GRAND BALLROOM B1 + B2	890
GRAND BALLROOM B2 + B3	800

* Standard Capacity illustrated. Higher capacities can be achieved with less staging and AV services and reduced furniture spacing. Please consider your event requirements when viewing capacities

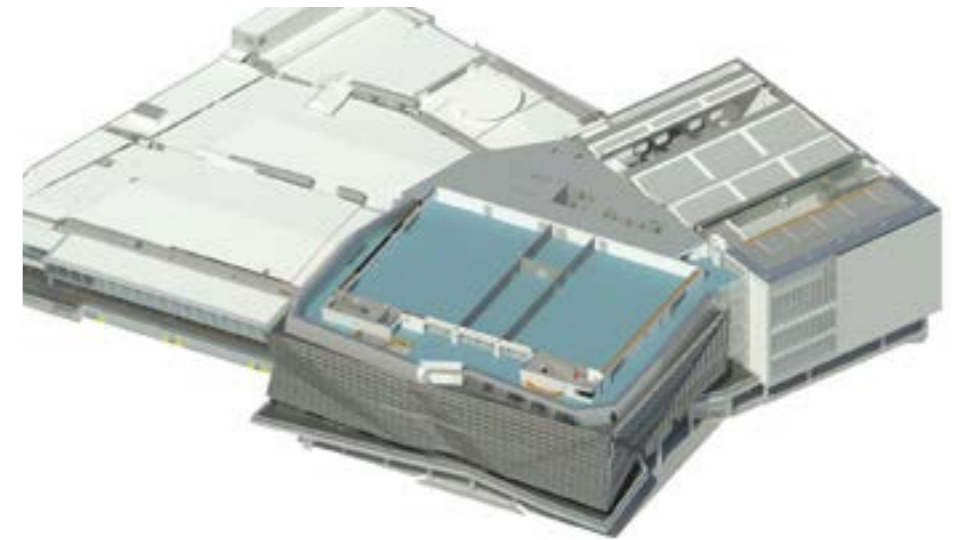
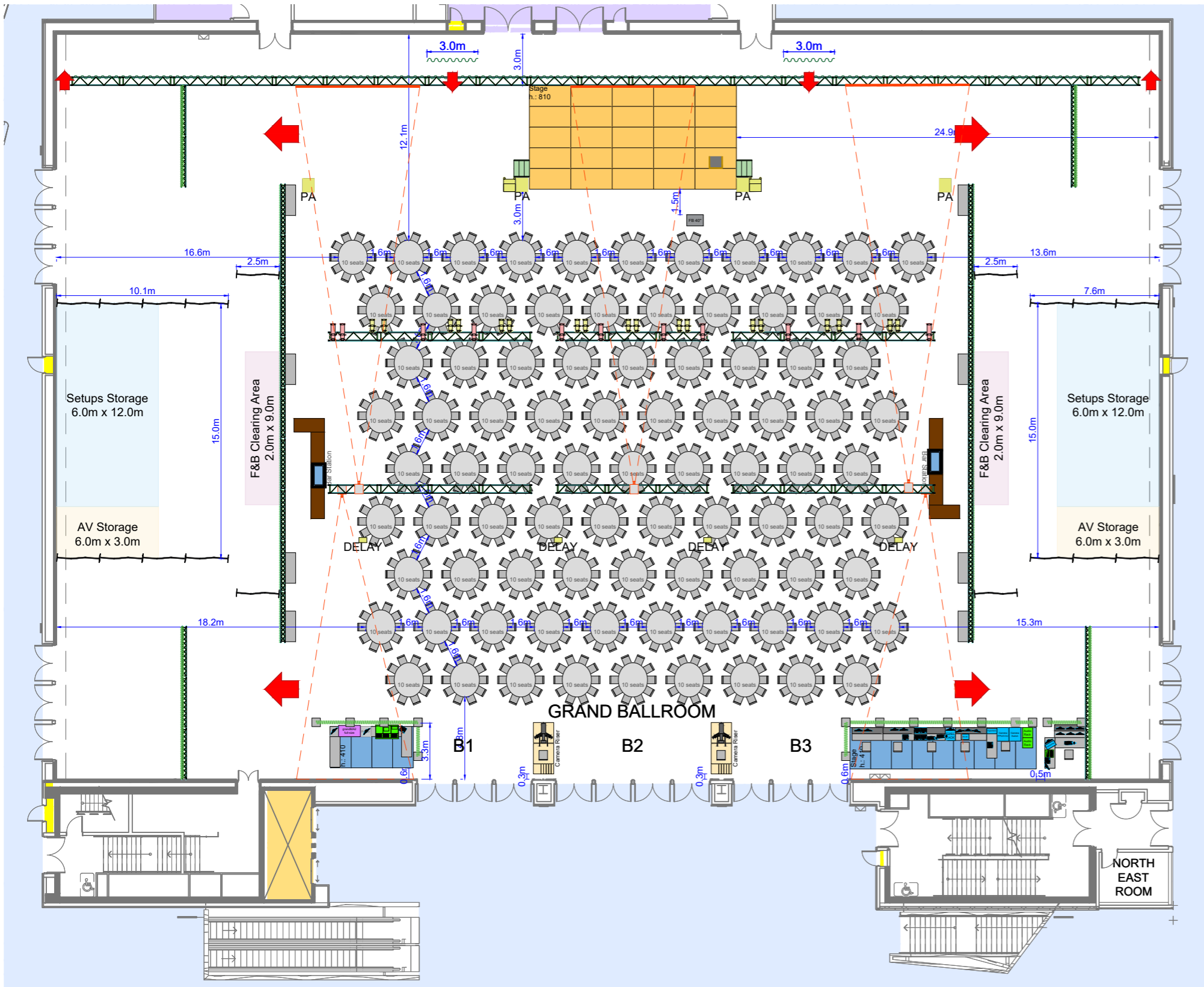

Axonometric cutaway view of Level 5 Convention Centre

ROOM NAME	BANQUET
GRAND BALLROOM	2000
GRAND BALLROOM B1	620
GRAND BALLROOM B2	NA
GRAND BALLROOM B3	530
GRAND BALLROOM MODE1	890
GRAND BALLROOM B1 + B2	890
GRAND BALLROOM B2 + B3	800

* Standard Capacity illustrated. Higher capacities can be achieved with less staging and AV services and reduced furniture spacing. Please consider your event requirements when viewing capacities

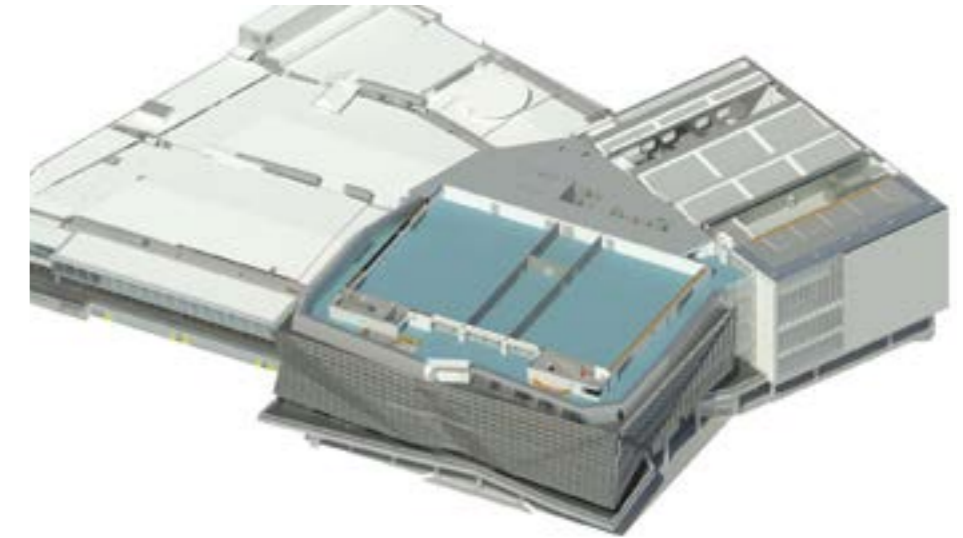
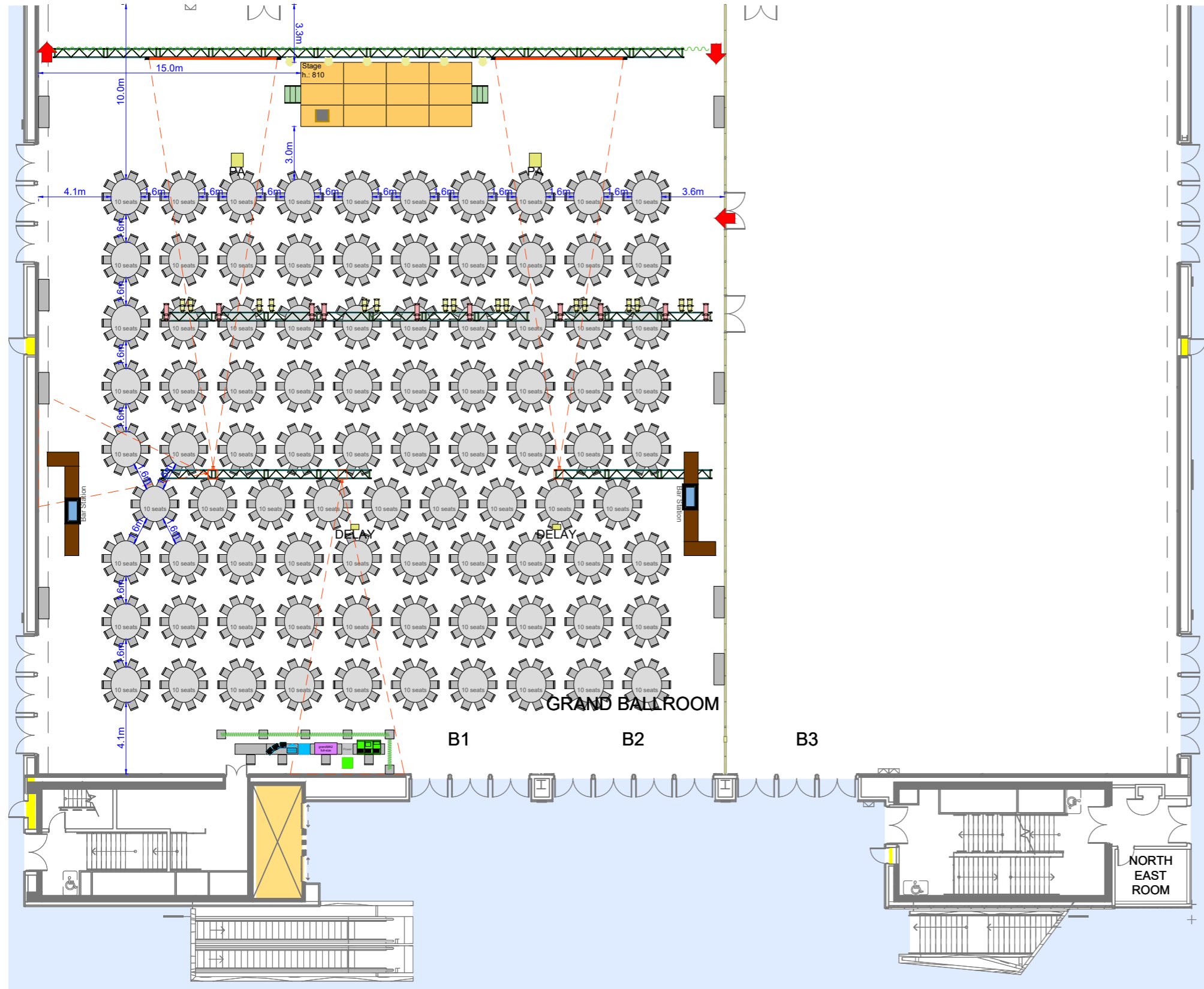

Axonometric cutaway view of Level 5 Convention Centre

ROOM NAME	BANQUET
GRAND BALLROOM	2000
GRAND BALLROOM B1	620
GRAND BALLROOM B2	NA
GRAND BALLROOM B3	530
GRAND BALLROOM MODE1	890
GRAND BALLROOM B1 + B2	890
GRAND BALLROOM B2 + B3	800

* Standard Capacity illustrated. Higher capacities can be achieved with less staging and AV services and reduced furniture spacing. Please consider your event requirements when viewing capacities

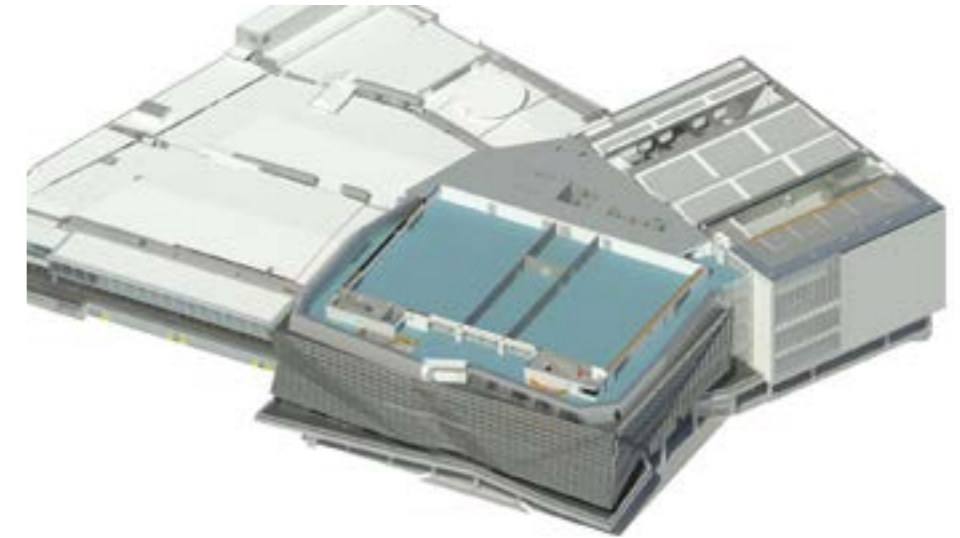
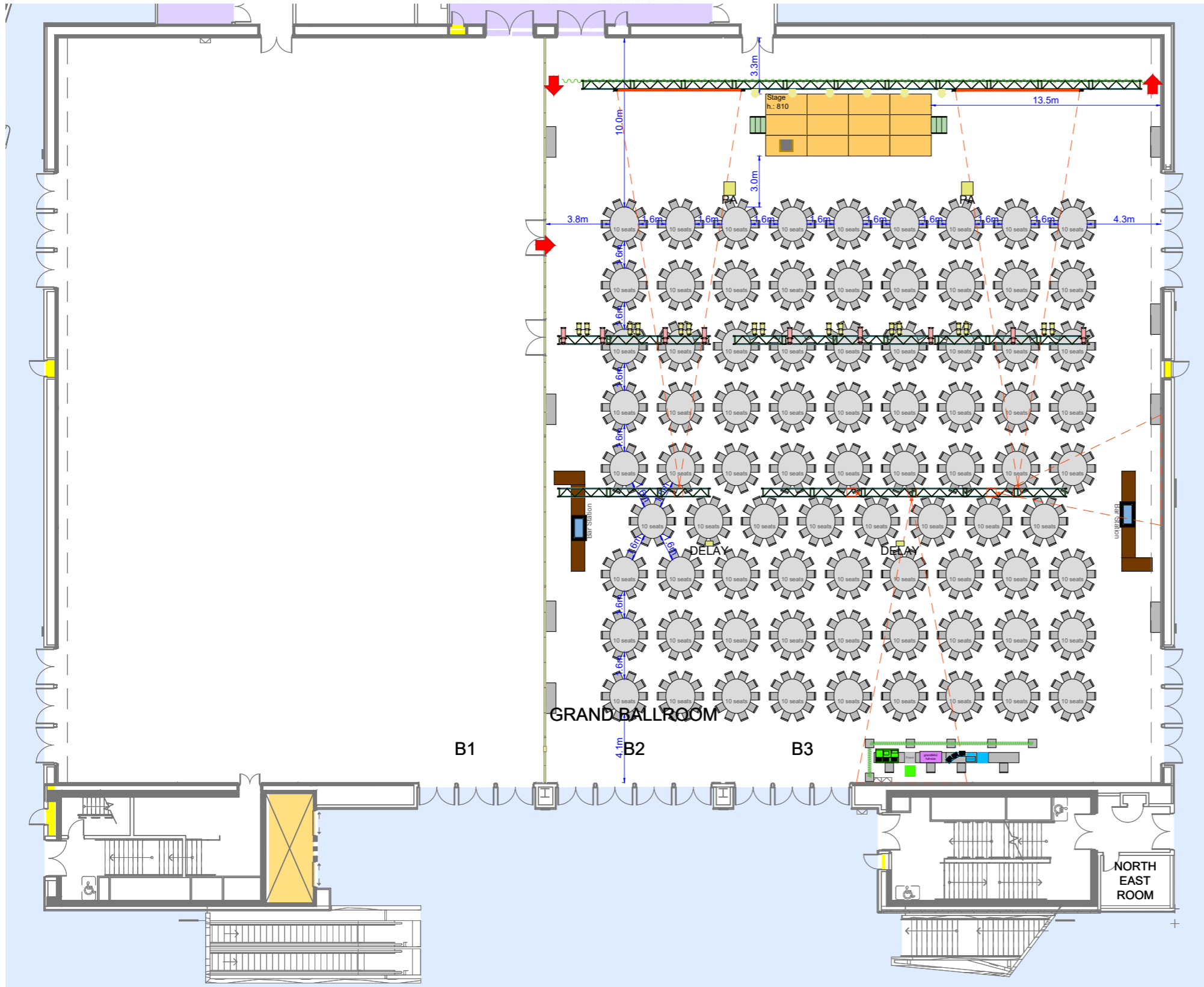

Axonometric cutaway view of Level 5 Convention Centre

ROOM NAME	BANQUET
GRAND BALLROOM	2000
GRAND BALLROOM B1	620
GRAND BALLROOM B2	NA
GRAND BALLROOM B3	530
GRAND BALLROOM B1 + B2	890
GRAND BALLROOM B2 + B3	800

* Standard Capacity illustrated. Higher capacities can be achieved with less staging and AV services and reduced furniture spacing. Please consider your event requirements when viewing capacities

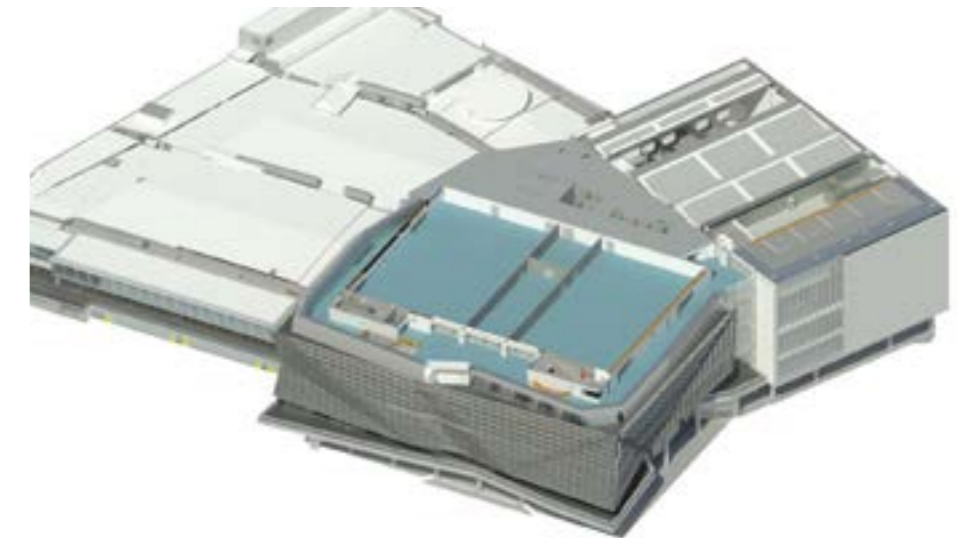
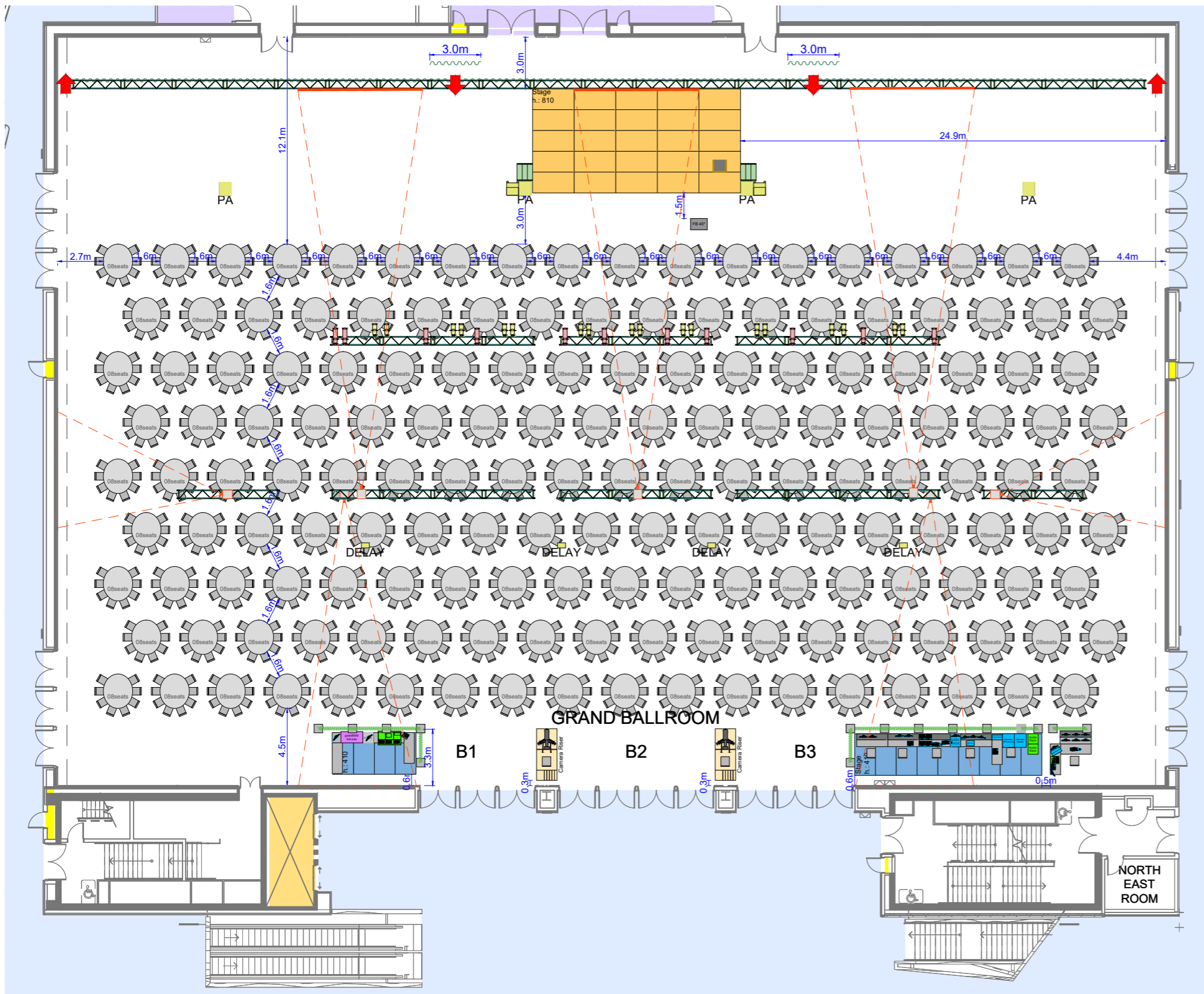

Axonometric cutaway view of Level 5 Convention Centre

ROOM NAME	CABARET
GRAND BALLROOM	1296
GRAND BALLROOM B1	504
GRAND BALLROOM B2	NA
GRAND BALLROOM B3	432
GRAND BALLROOM MODE1	720
GRAND BALLROOM B1 + B2	720
GRAND BALLROOM B2 + B3	648

* Standard Capacity illustrated. Higher capacities can be achieved with less staging and AV services and reduced furniture spacing. Please consider your event requirements when viewing capacities

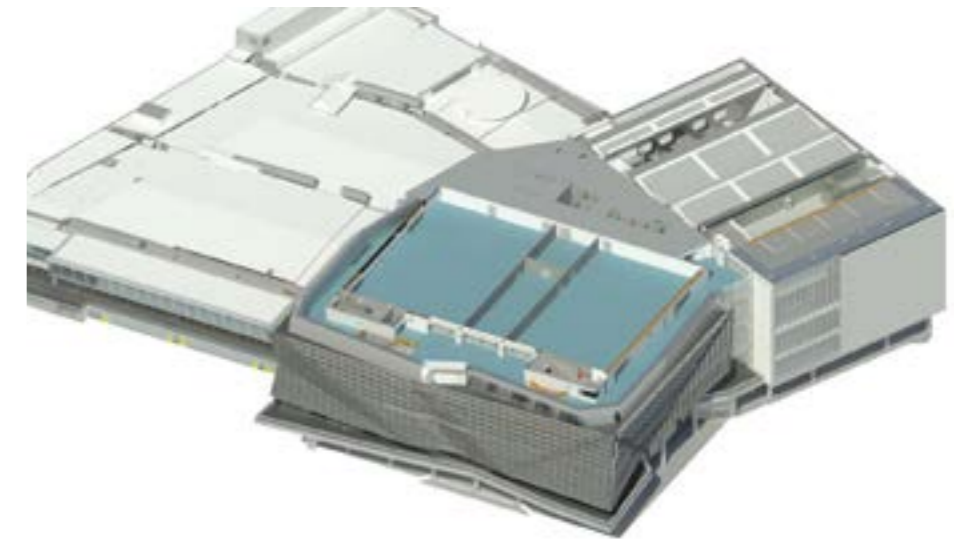

Axonometric cutaway view of Level 5 Convention Centre

ROOM NAME	CABARET
GRAND BALLROOM	1296
GRAND BALLROOM B1	504
GRAND BALLROOM B2	NA
GRAND BALLROOM B3	432
GRAND BALLROOM MODE1	720
GRAND BALLROOM B1 + B2	720
GRAND BALLROOM B2 + B3	648

* Standard Capacity illustrated. Higher capacities can be achieved with less staging and AV services and reduced furniture spacing. Please consider your event requirements when viewing capacities

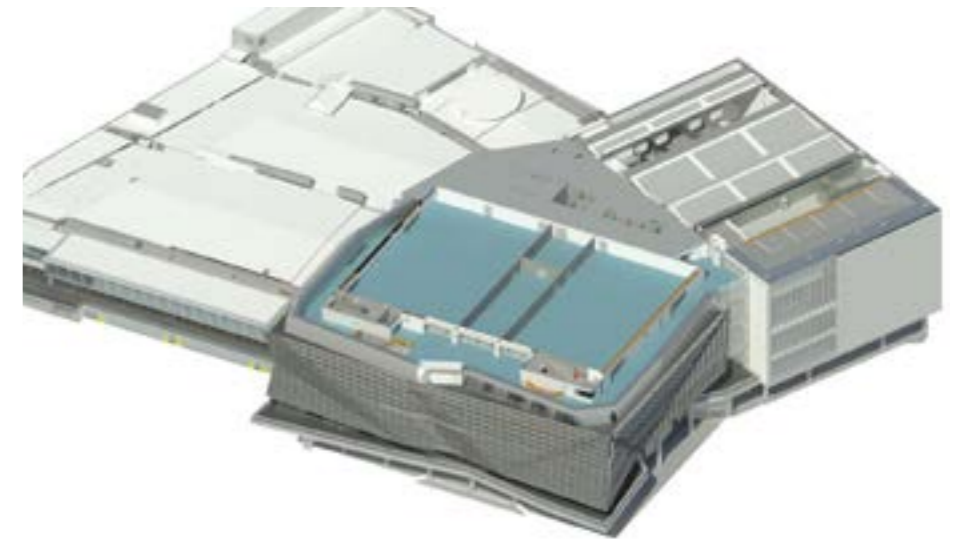
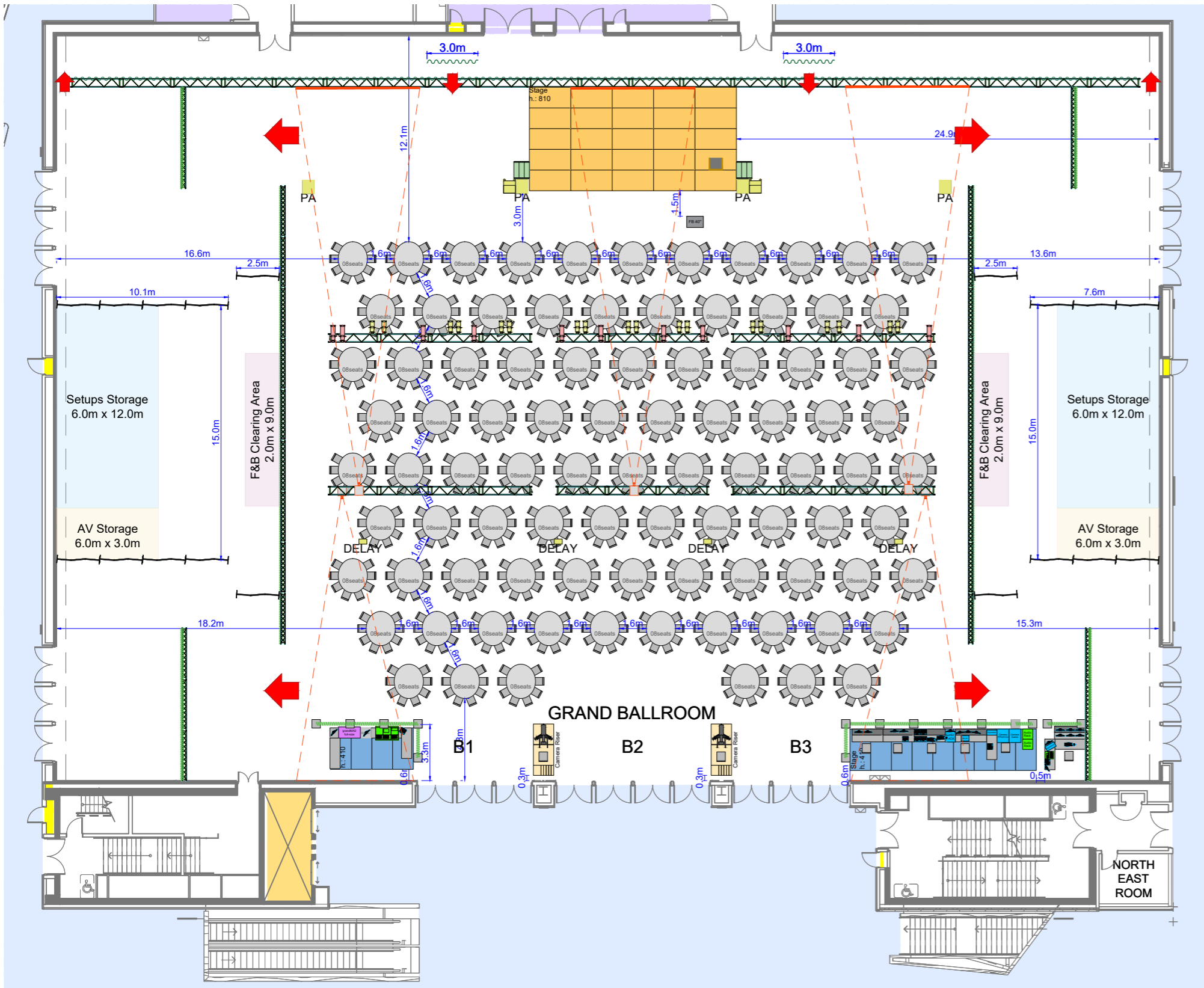

Axonometric cutaway view of Level 5 Convention Centre

ROOM NAME	CABARET
GRAND BALLROOM	1296
GRAND BALLROOM B1	504
GRAND BALLROOM B2	NA
GRAND BALLROOM B3	432
GRAND BALLROOM MODE1	720
GRAND BALLROOM B1 + B2	720
GRAND BALLROOM B2 + B3	648

* Standard Capacity illustrated. Higher capacities can be achieved with less staging and AV services and reduced furniture spacing. Please consider your event requirements when viewing capacities

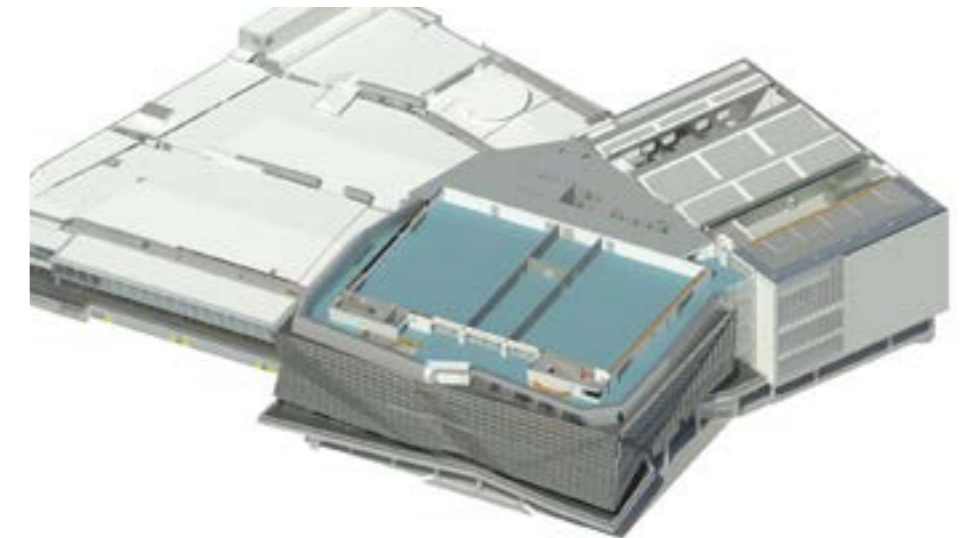
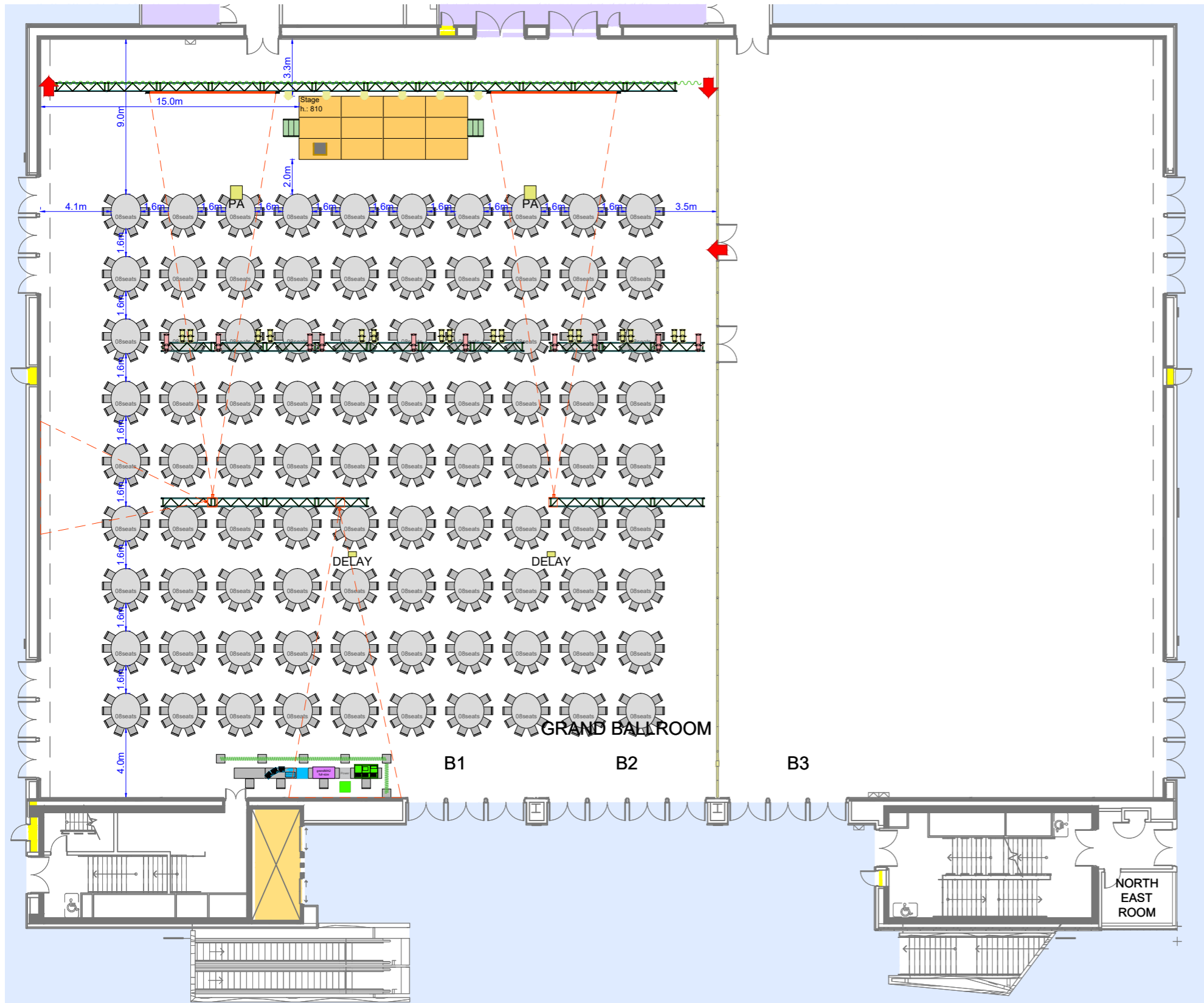

Axonometric cutaway view of Level 5 Convention Centre

ROOM NAME	CABARET
GRAND BALLROOM	1296
GRAND BALLROOM B1	504
GRAND BALLROOM B2	NA
GRAND BALLROOM B3	432
GRAND BALLROOM MODE1	720
GRAND BALLROOM B1 + B2	720
GRAND BALLROOM B2 + B3	648

* Standard Capacity illustrated. Higher capacities can be achieved with less staging and AV services and reduced furniture spacing. Please consider your event requirements when viewing capacities

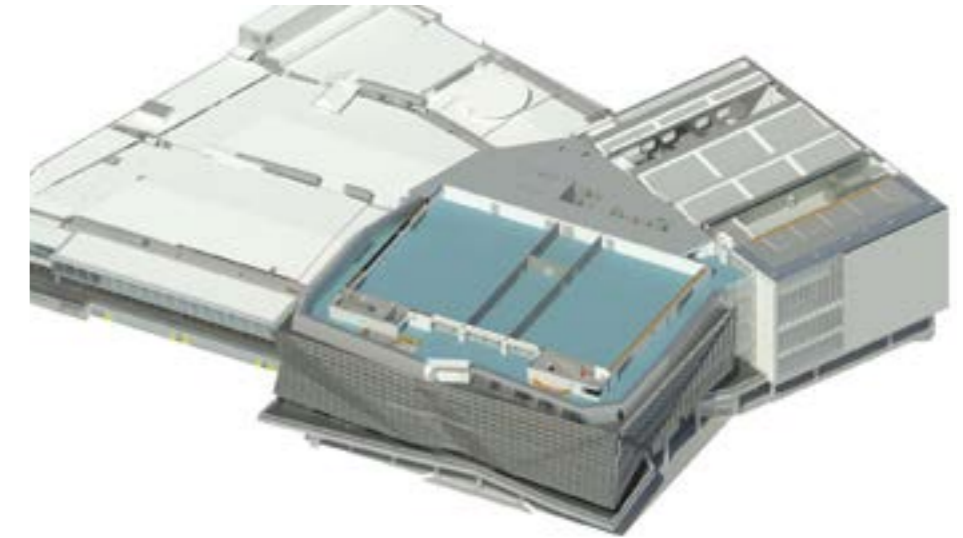

Axonometric cutaway view of Level 5 Convention Centre

ROOM NAME	CABARET
GRAND BALLROOM	1296
GRAND BALLROOM B1	504
GRAND BALLROOM B2	NA
GRAND BALLROOM B3	432
GRAND BALLROOM B1 + B2	720
GRAND BALLROOM B2 + B3	648

* Standard Capacity illustrated. Higher capacities can be achieved with less staging and AV services and reduced furniture spacing. Please consider your event requirements when viewing capacities

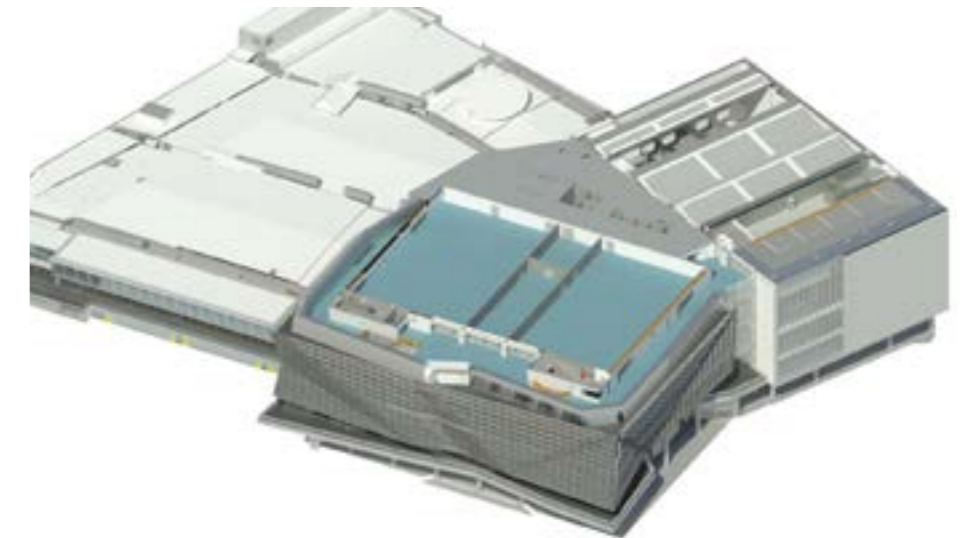

Axonometric cutaway view of Level 5 Convention Centre

ROOM NAME	CLASSROOM
GRAND BALLROOM	1764
GRAND BALLROOM B1	693
GRAND BALLROOM B2	NA
GRAND BALLROOM B3	630
GRAND BALLROOM MODE1	1008
GRAND BALLROOM B1 + B2	1008
GRAND BALLROOM B2 + B3	945

* Standard Capacity illustrated. Higher capacities can be achieved with less staging and AV services and reduced furniture spacing. Please consider your event requirements when viewing capacities

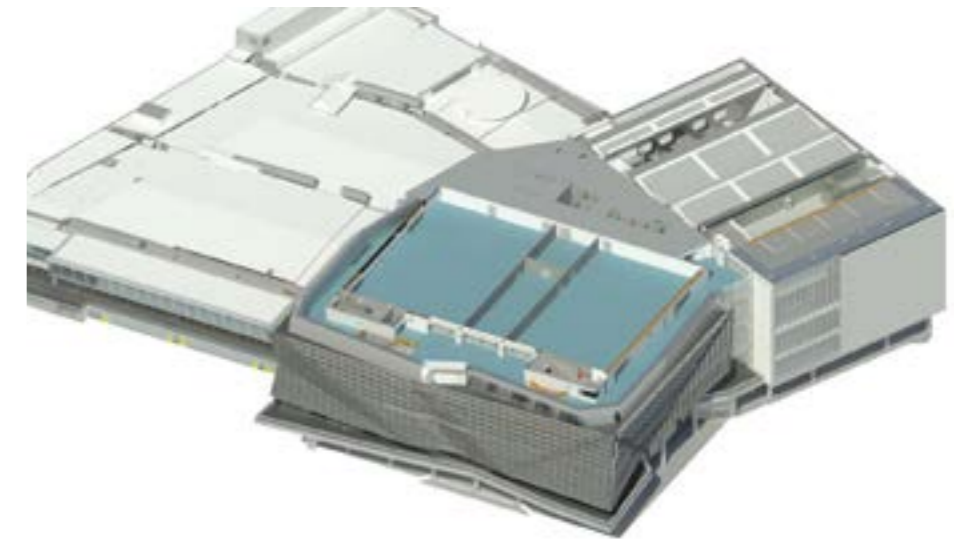
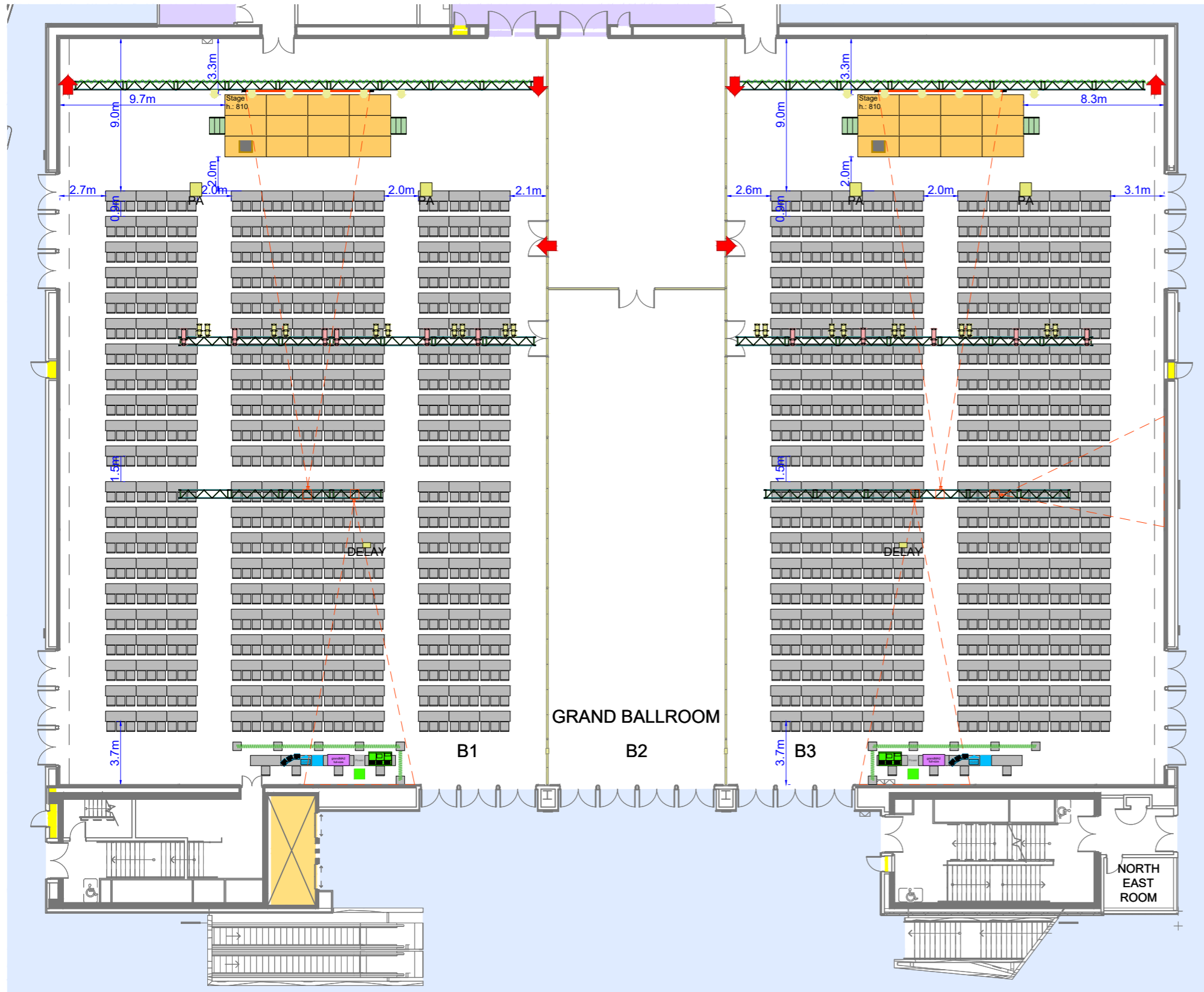

Axonometric cutaway view of Level 5 Convention Centre

ROOM NAME	CLASSROOM
GRAND BALLROOM	1764
GRAND BALLROOM B1	693
GRAND BALLROOM B2	NA
GRAND BALLROOM B3	630
GRAND BALLROOM MODE1	1008
GRAND BALLROOM B1 + B2	1008
GRAND BALLROOM B2 + B3	945

* Standard Capacity illustrated. Higher capacities can be achieved with less staging and AV services and reduced furniture spacing. Please consider your event requirements when viewing capacities

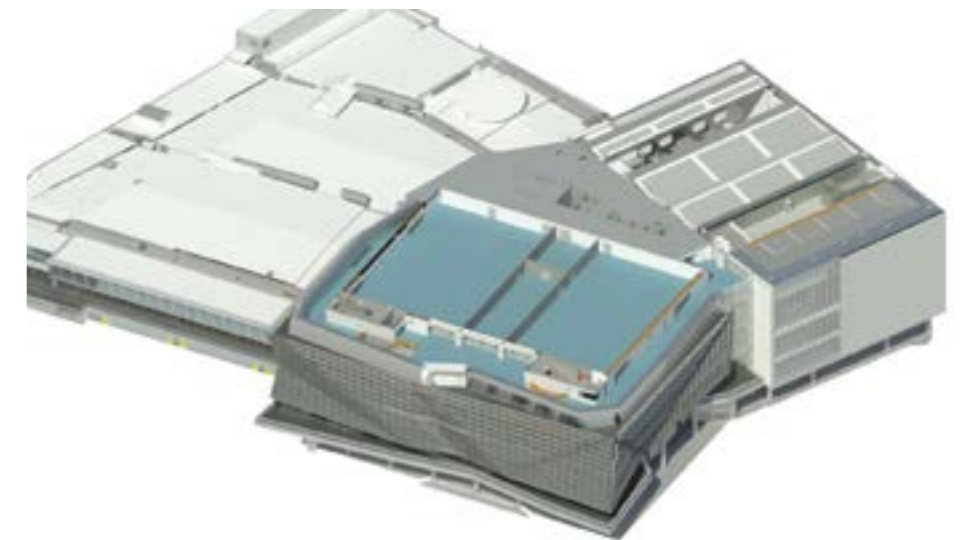
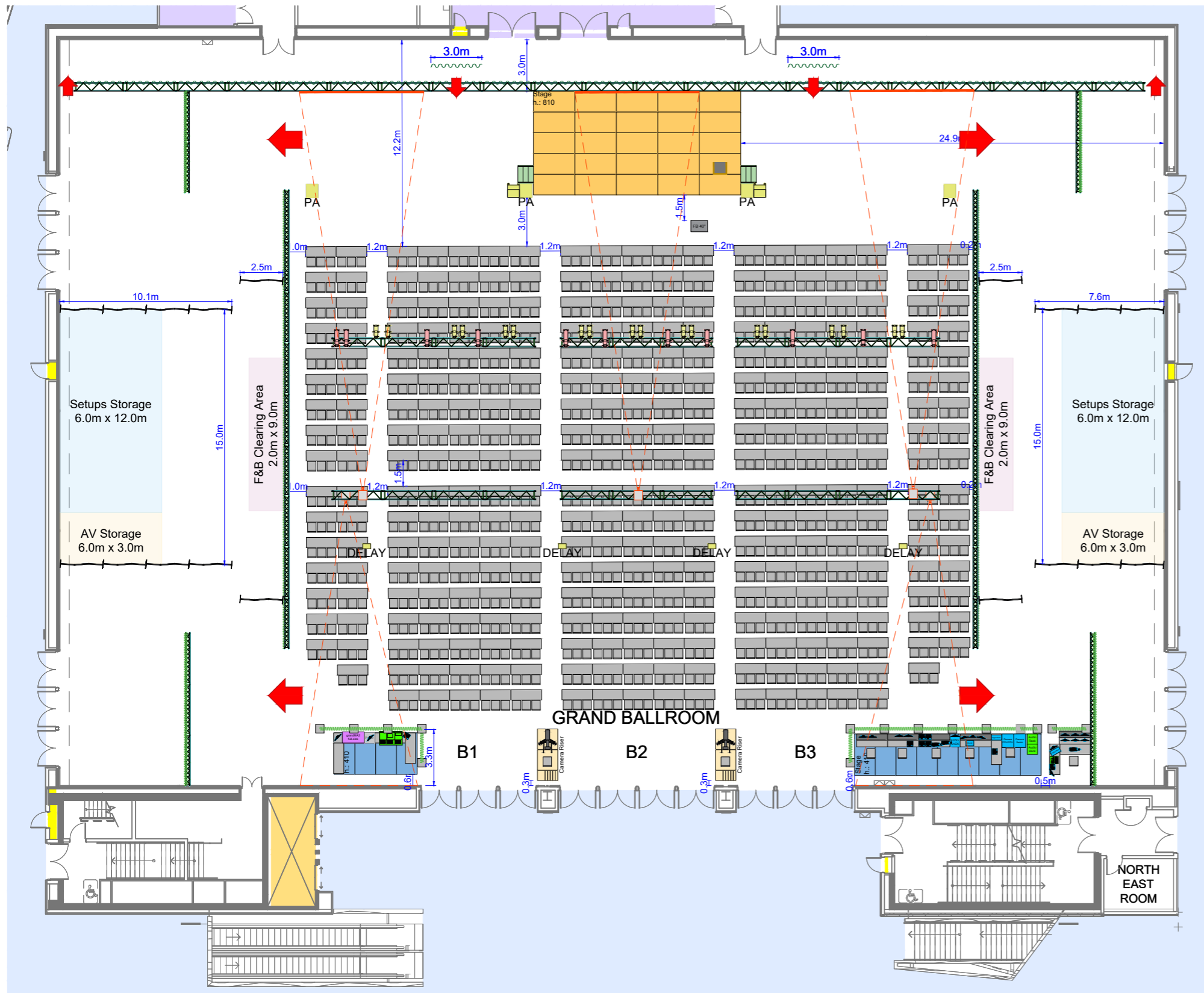

Axonometric cutaway view of Level 5 Convention Centre

ROOM NAME	CLASSROOM
GRAND BALLROOM	1764
GRAND BALLROOM B1	693
GRAND BALLROOM B2	NA
GRAND BALLROOM B3	630
GRAND BALLROOM MODE1	1008
GRAND BALLROOM B1 + B2	1008
GRAND BALLROOM B2 + B3	945

* Standard Capacity illustrated. Higher capacities can be achieved with less staging and AV services and reduced furniture spacing. Please consider your event requirements when viewing capacities

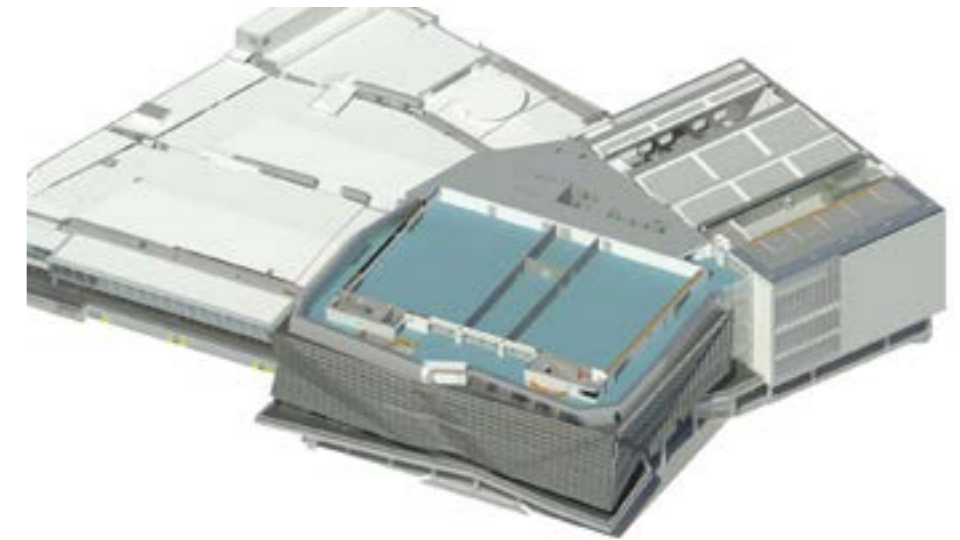
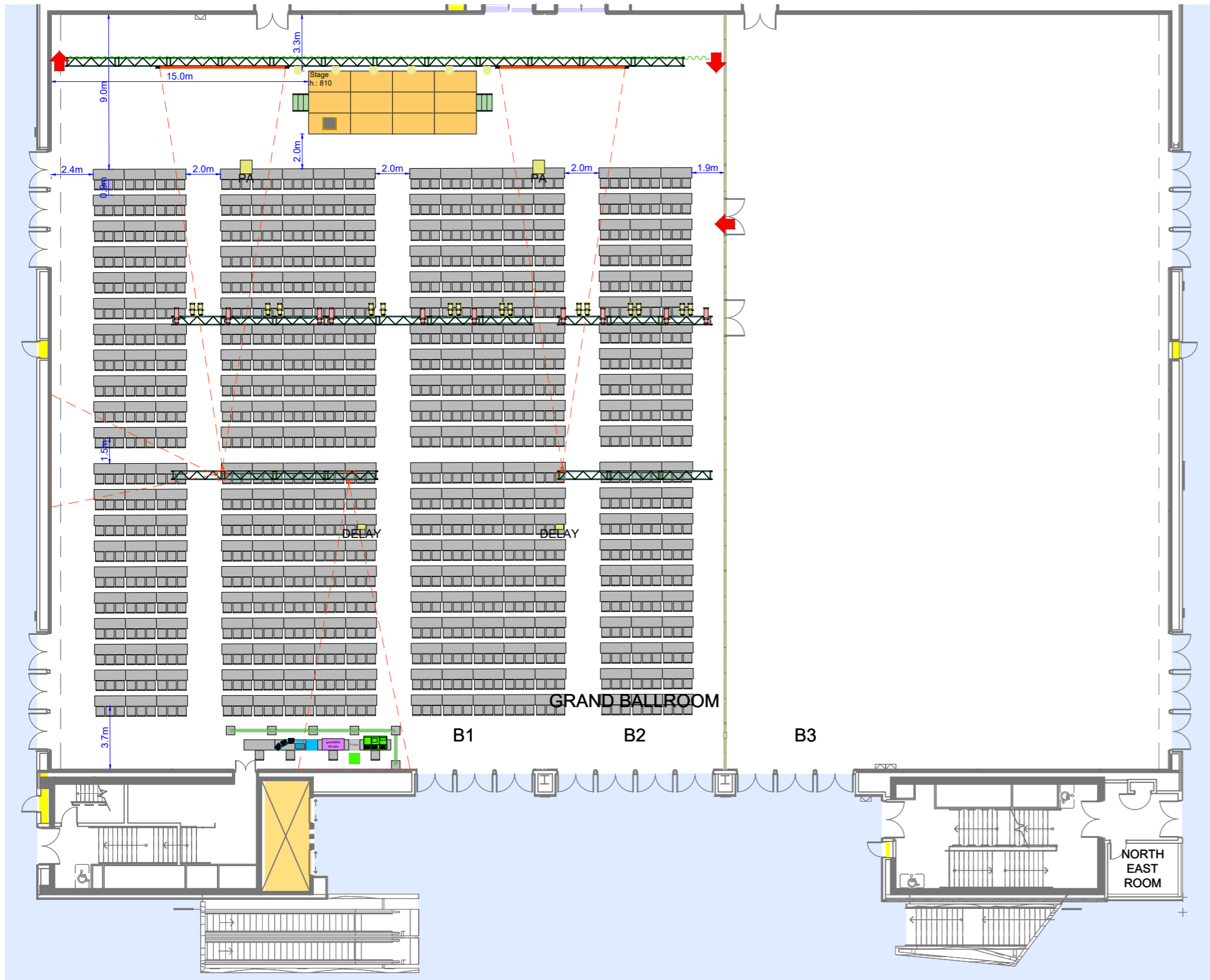

Axonometric cutaway view of Level 5 Convention Centre

ROOM NAME	CLASSROOM
GRAND BALLROOM	1764
GRAND BALLROOM B1	693
GRAND BALLROOM B2	NA
GRAND BALLROOM B3	630
GRAND BALLROOM MODE1	1008
GRAND BALLROOM B1 + B2	1008
GRAND BALLROOM B2 + B3	945

* Standard Capacity illustrated. Higher capacities can be achieved with less staging and AV services and reduced furniture spacing. Please consider your event requirements when viewing capacities

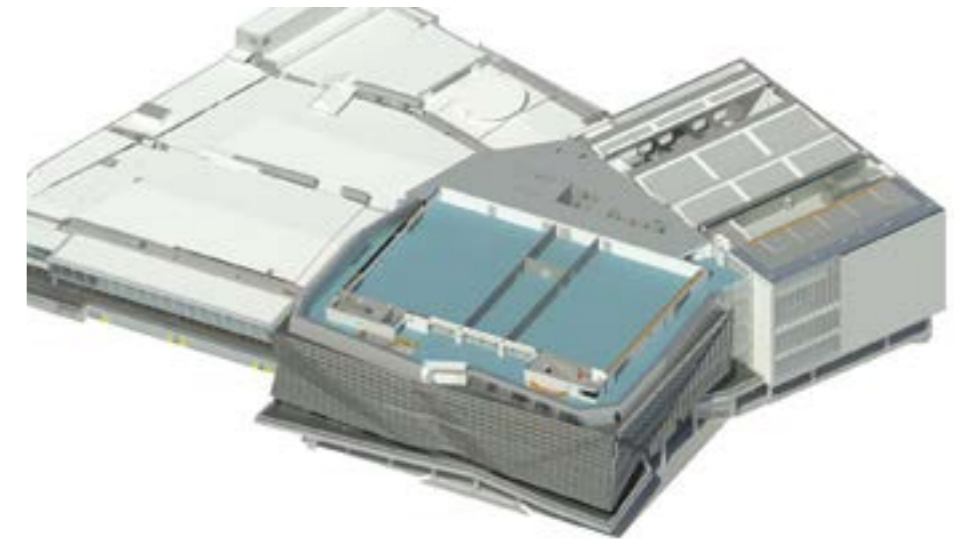

Axonometric cutaway view of Level 5 Convention Centre

ROOM NAME	CABARET
GRAND BALLROOM	1296
GRAND BALLROOM B1	504
GRAND BALLROOM B2	NA
GRAND BALLROOM B3	432
GRAND BALLROOM MODE1	720
GRAND BALLROOM B1 + B2	720
GRAND BALLROOM B2 + B3	648

* Standard Capacity illustrated. Higher capacities can be achieved with less staging and AV services and reduced furniture spacing. Please consider your event requirements when viewing capacities

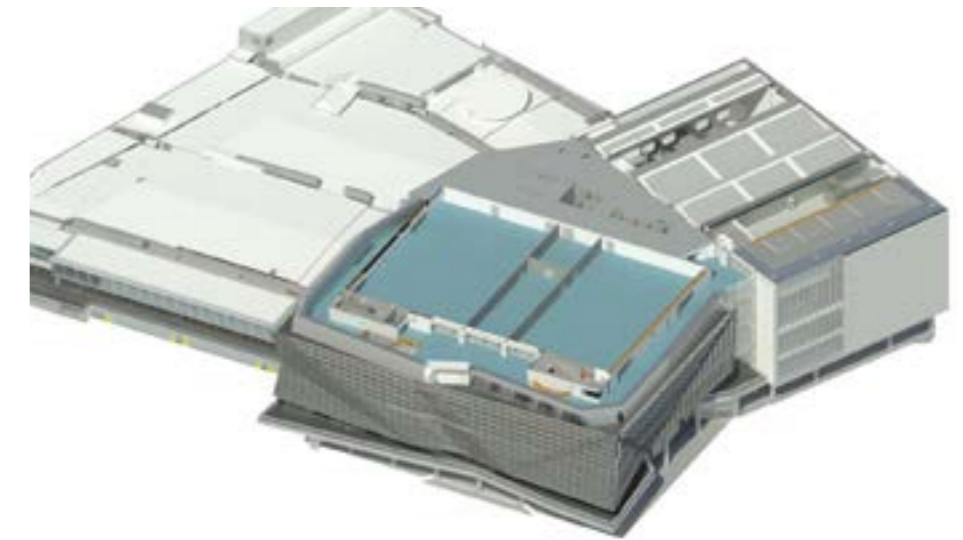

Axonometric cutaway view of Level 5 Convention Centre

ROOM NAME	THEATRE
GRAND BALLROOM	2784
GRAND BALLROOM B1	1160
GRAND BALLROOM B2	NA
GRAND BALLROOM B3	986
GRAND BALLROOM MODE1	1682
GRAND BALLROOM B1 + B2	1682
GRAND BALLROOM B2 + B3	1508

* Standard Capacity illustrated. Higher capacities can be achieved with less staging and AV services and reduced furniture spacing. Please consider your event requirements when viewing capacities

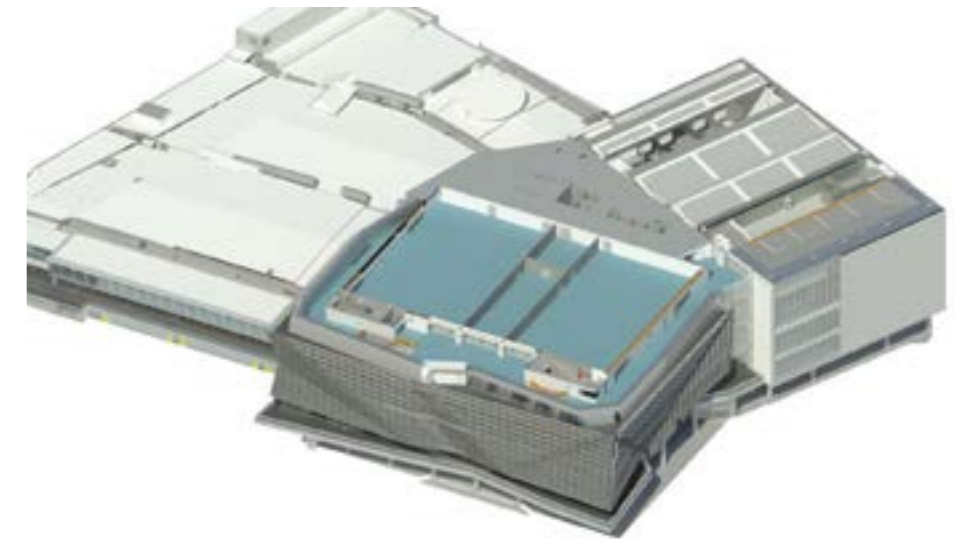
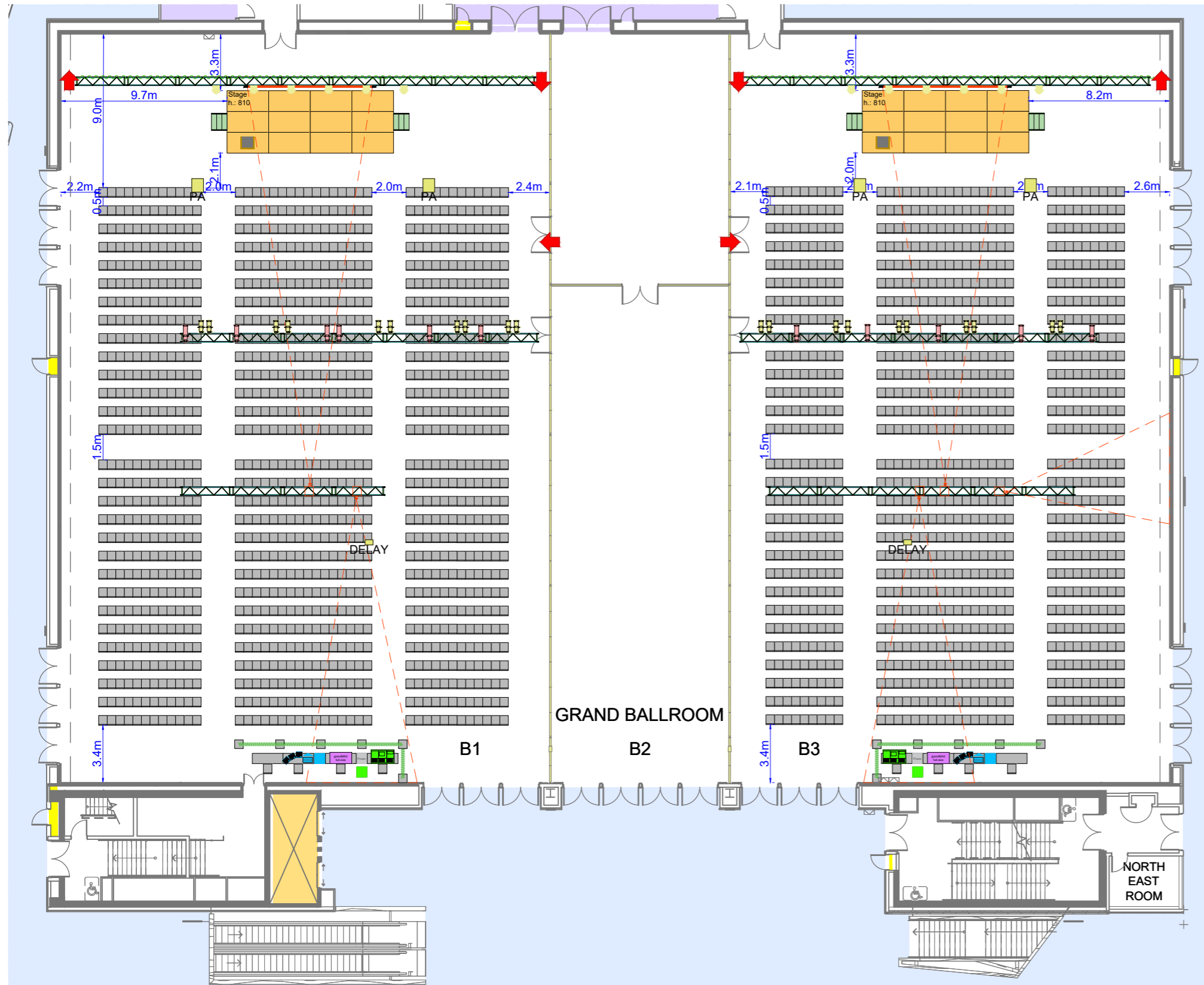

Axonometric cutaway view of Level 5 Convention Centre

ROOM NAME	THEATRE
GRAND BALLROOM	2784
GRAND BALLROOM B1	1160
GRAND BALLROOM B2	NA
GRAND BALLROOM B3	986
GRAND BALLROOM MODE1	1682
GRAND BALLROOM B1 + B2	1682
GRAND BALLROOM B2 + B3	1508

* Standard Capacity illustrated. Higher capacities can be achieved with less staging and AV services and reduced furniture spacing. Please consider your event requirements when viewing capacities

Convention Centre Level 5 - Grand Ballroom theatre layout MODE 1

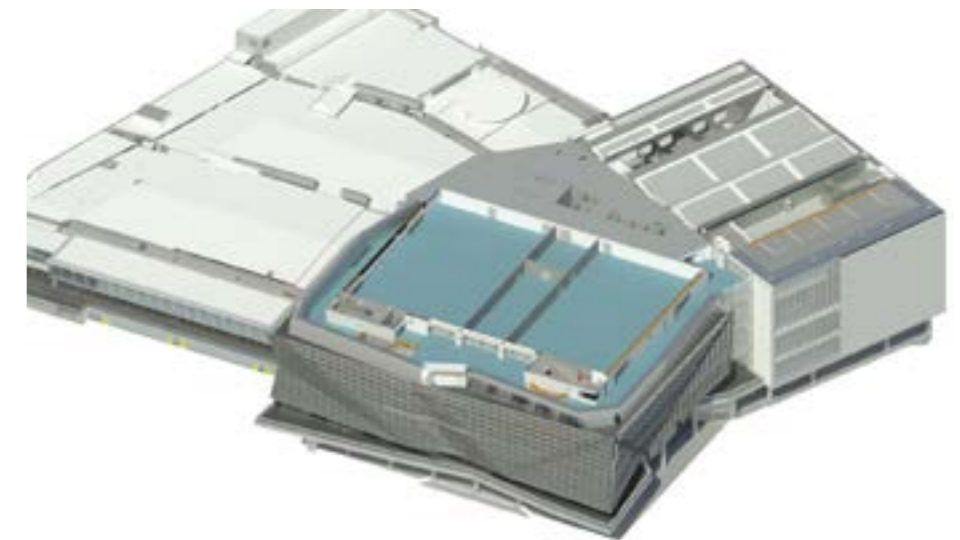
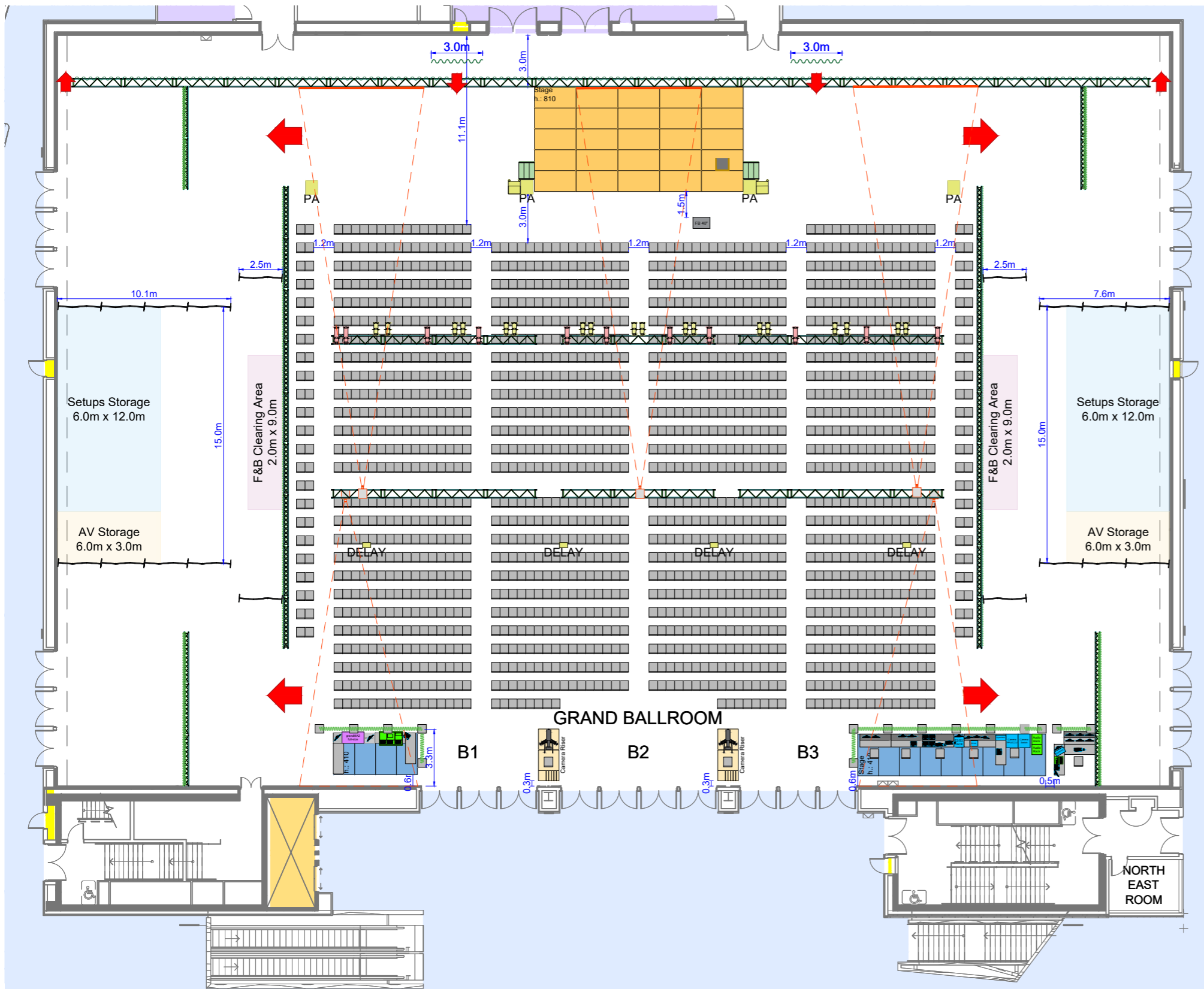

Axonometric cutaway view of Level 5 Convention Centre

ROOM NAME	THEATRE
GRAND BALLROOM	2784
GRAND BALLROOM B1	1160
GRAND BALLROOM B2	NA
GRAND BALLROOM B3	986
GRAND BALLROOM MODE1	1682
GRAND BALLROOM B1 + B2	1682
GRAND BALLROOM B2 + B3	1508

* Standard Capacity illustrated. Higher capacities can be achieved with less staging and AV services and reduced furniture spacing. Please consider your event requirements when viewing capacities

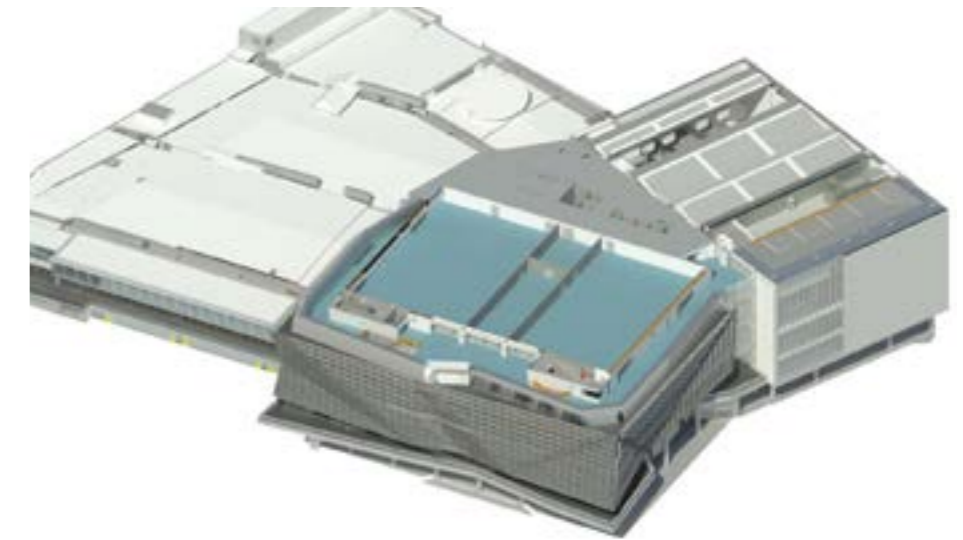
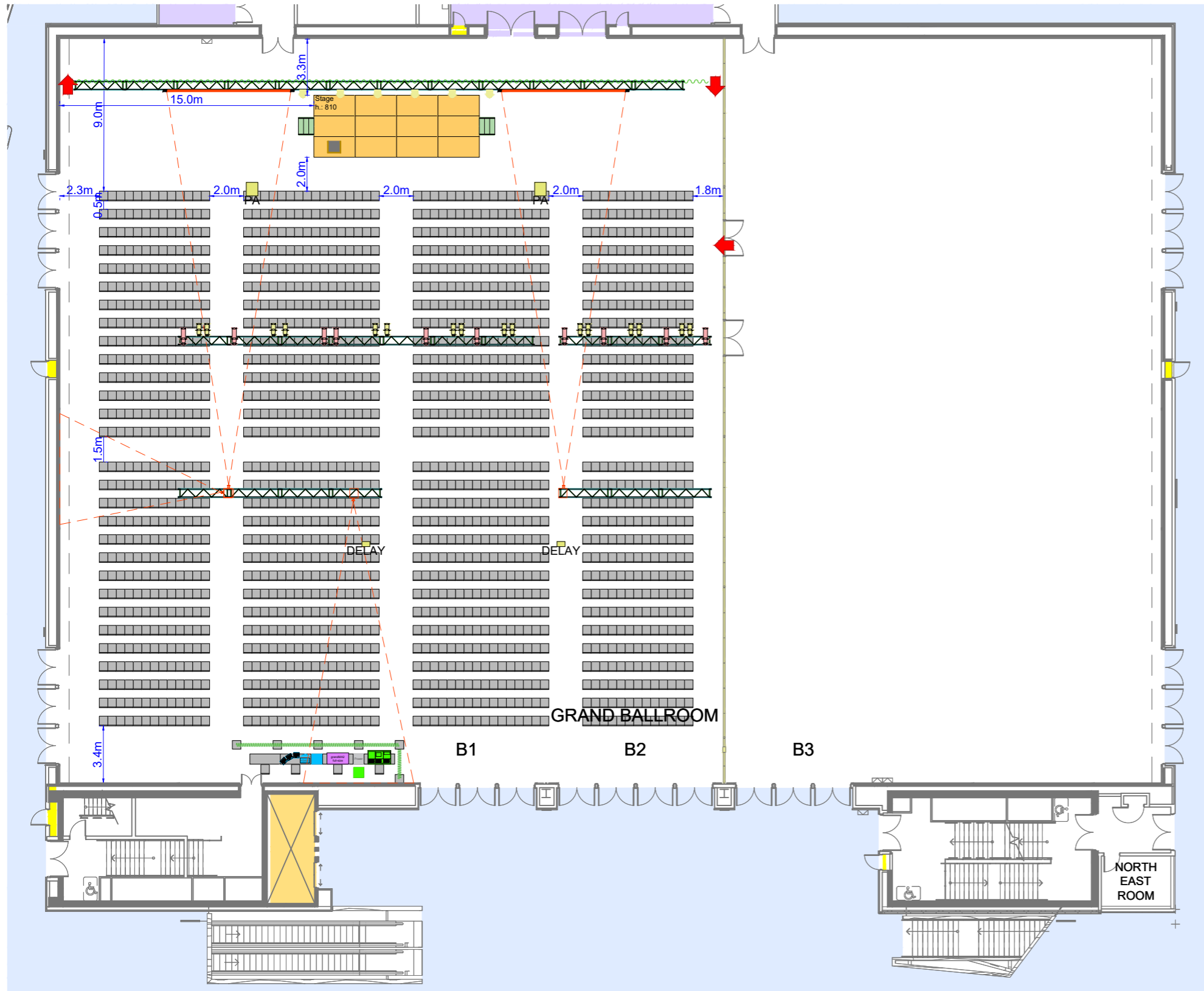

Axonometric cutaway view of Level 5 Convention Centre

ROOM NAME	THEATRE
GRAND BALLROOM	2784
GRAND BALLROOM B1	1160
GRAND BALLROOM B2	NA
GRAND BALLROOM B3	986
GRAND BALLROOM MODE1	1682
GRAND BALLROOM B1 + B2	1682
GRAND BALLROOM B2 + B3	1508

* Standard Capacity illustrated. Higher capacities can be achieved with less staging and AV services and reduced furniture spacing. Please consider your event requirements when viewing capacities

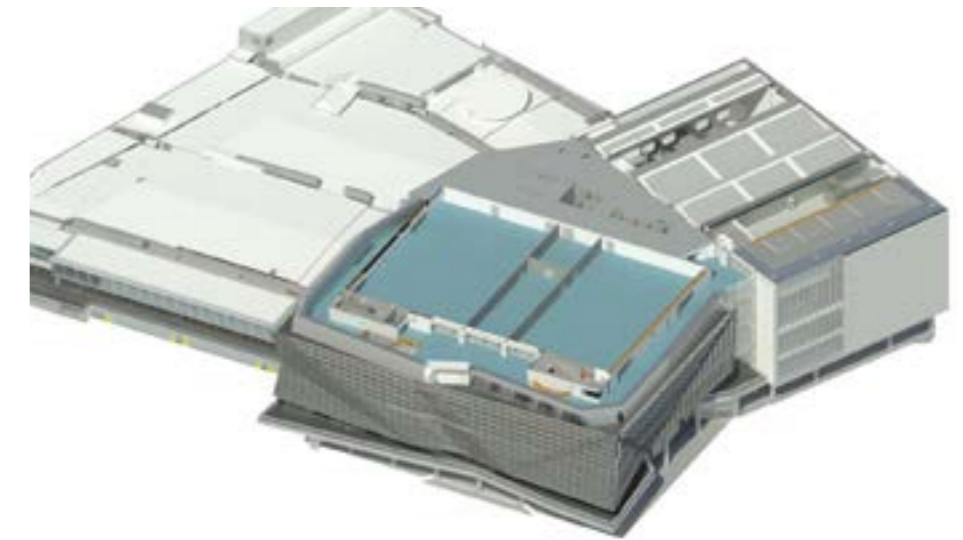

Axonometric cutaway view of Level 5 Convention Centre

ROOM NAME	THEATRE
GRAND BALLROOM	2784
GRAND BALLROOM B1	1160
GRAND BALLROOM B2	NA
GRAND BALLROOM B3	986
GRAND BALLROOM MODE1	1682
GRAND BALLROOM B1 + B2	1682
GRAND BALLROOM B2 + B3	1508

* Standard Capacity illustrated. Higher capacities can be achieved with less staging and AV services and reduced furniture spacing. Please consider your event requirements when viewing capacities

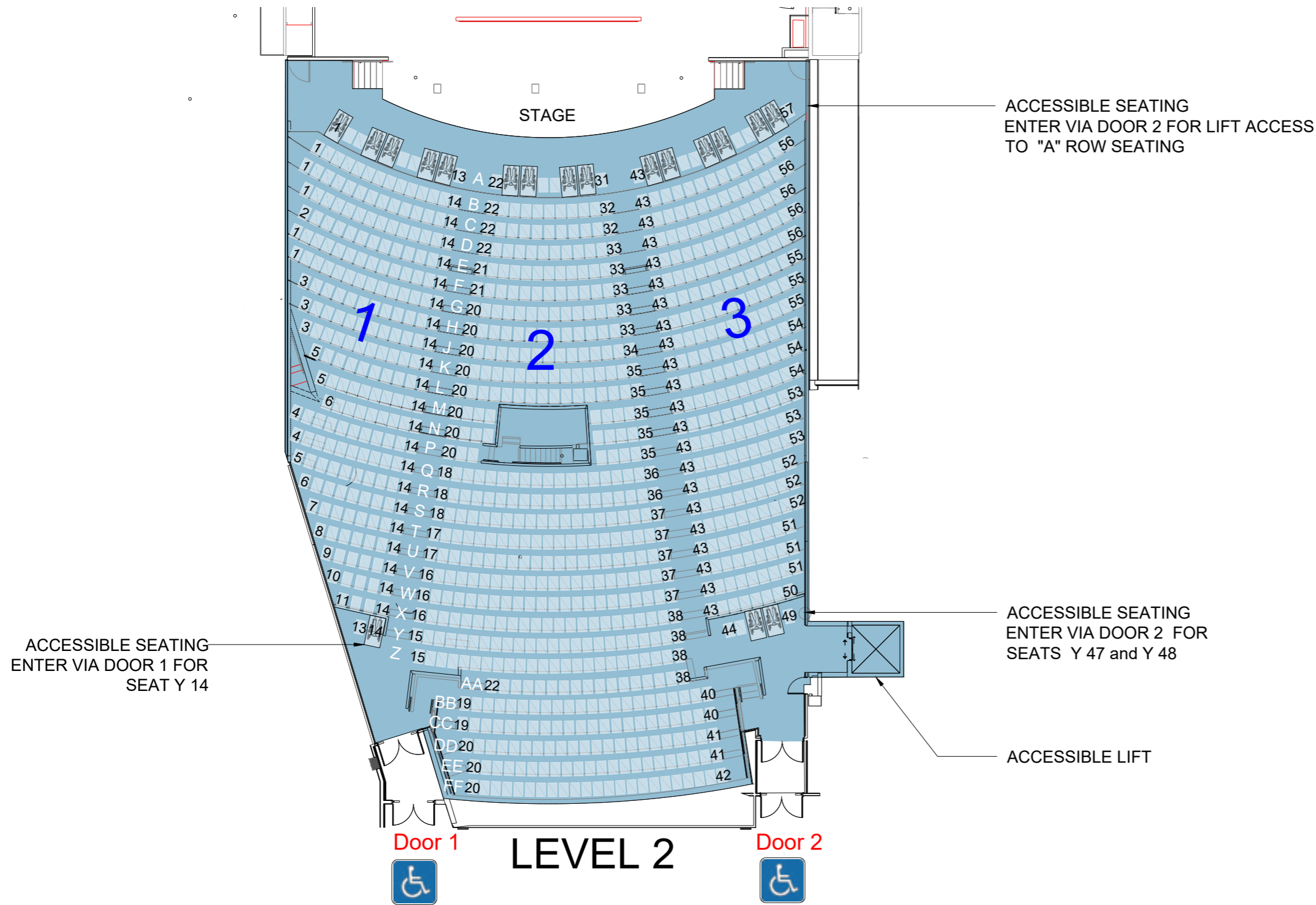

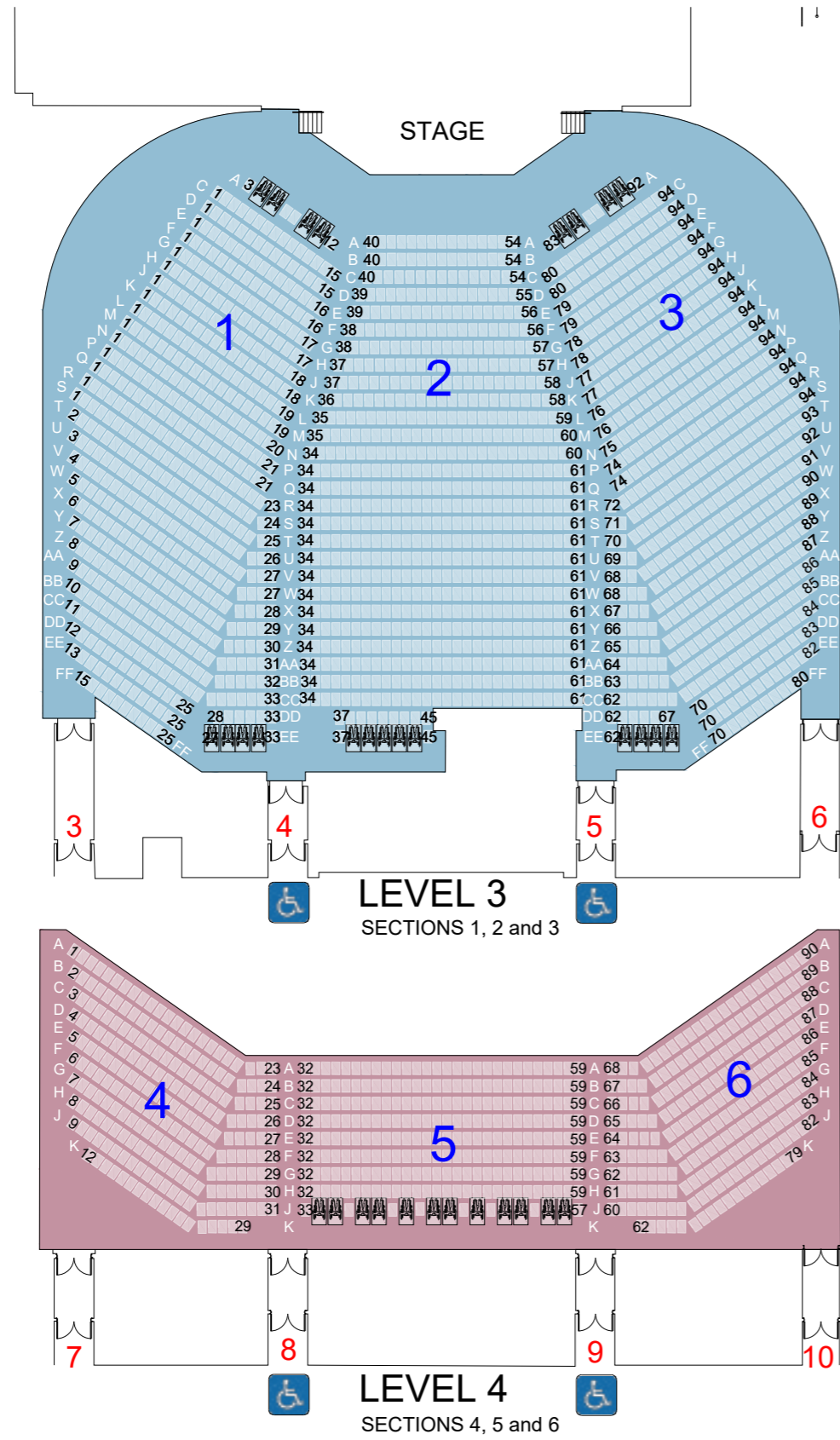

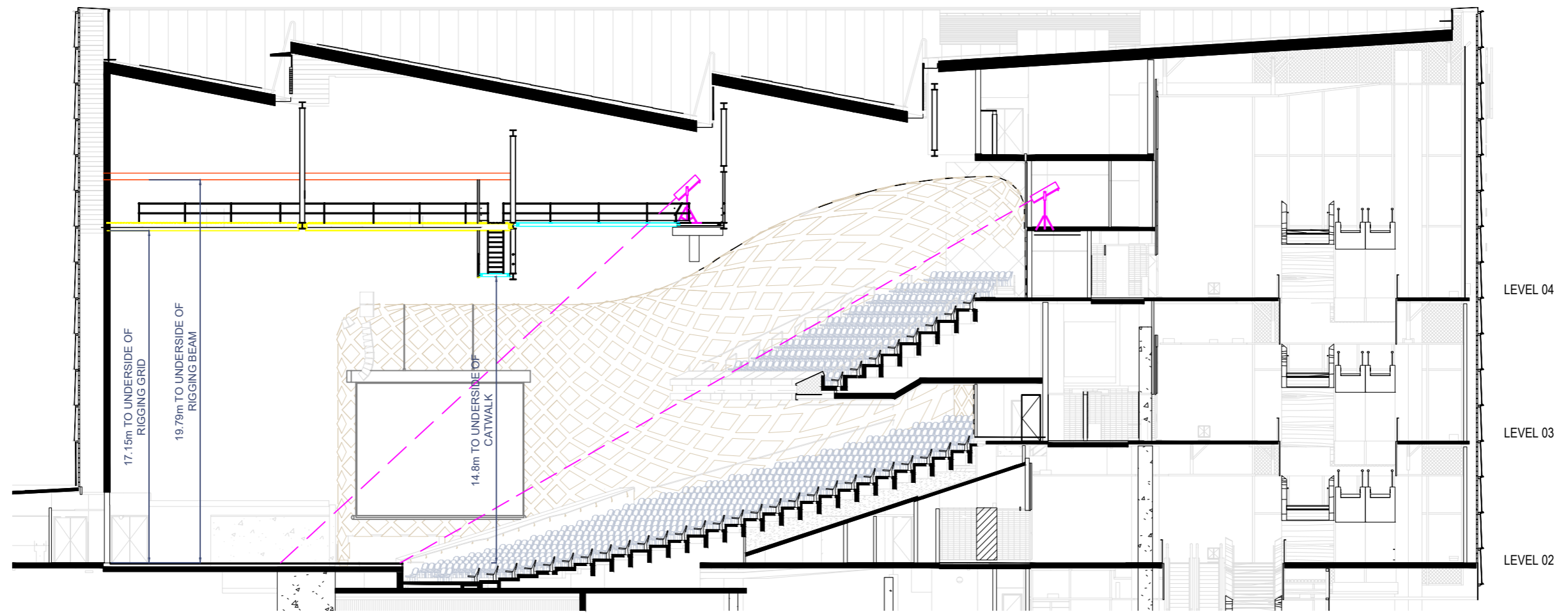

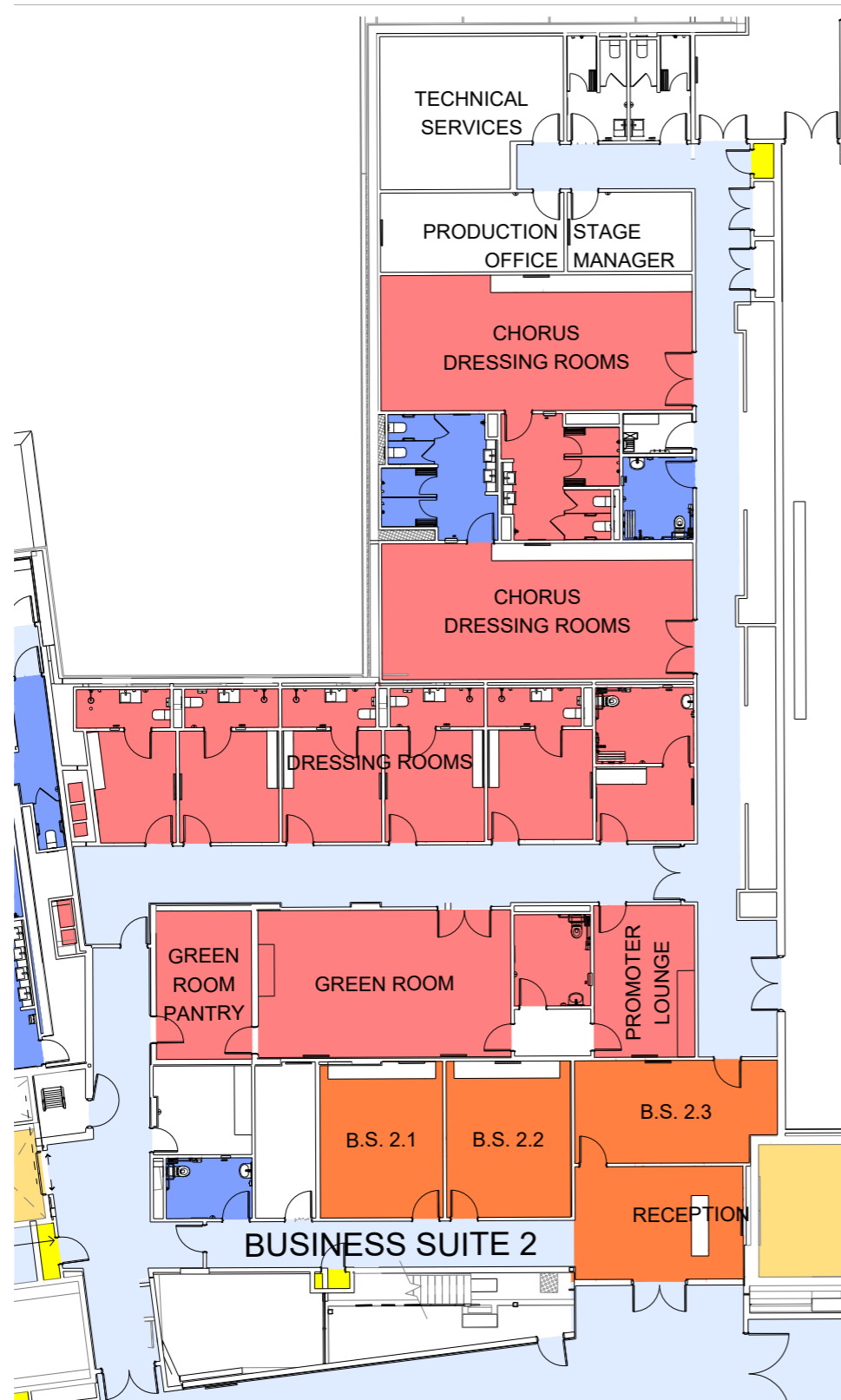

LEGEND

- Circulation back of house
- Circulation front of house
- Lifts
- Fire hydrant
- Toilets / facilities
- Business Suite 2
- Meeting Rooms, Parkside Ballroom and Gallery
- Darling Harbour Theatre Facilities

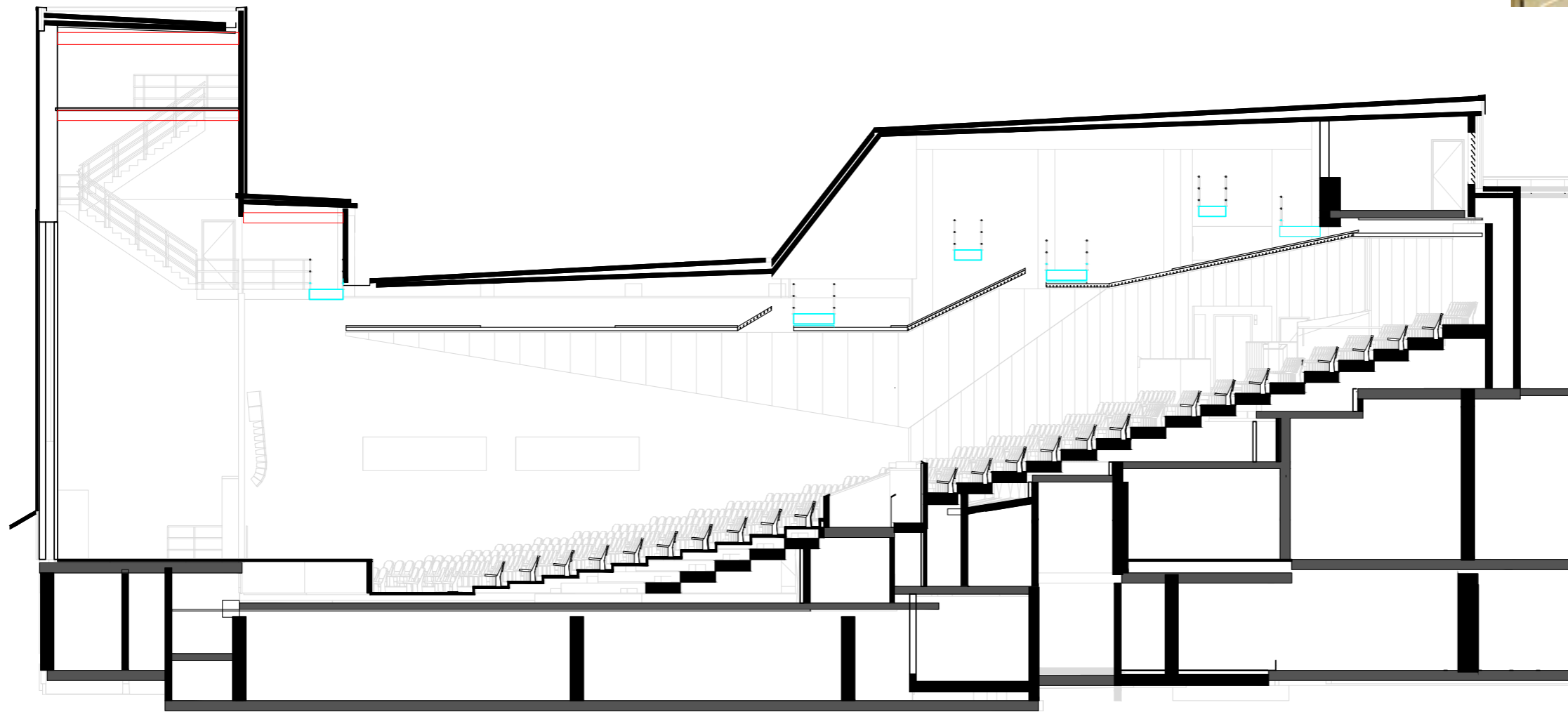

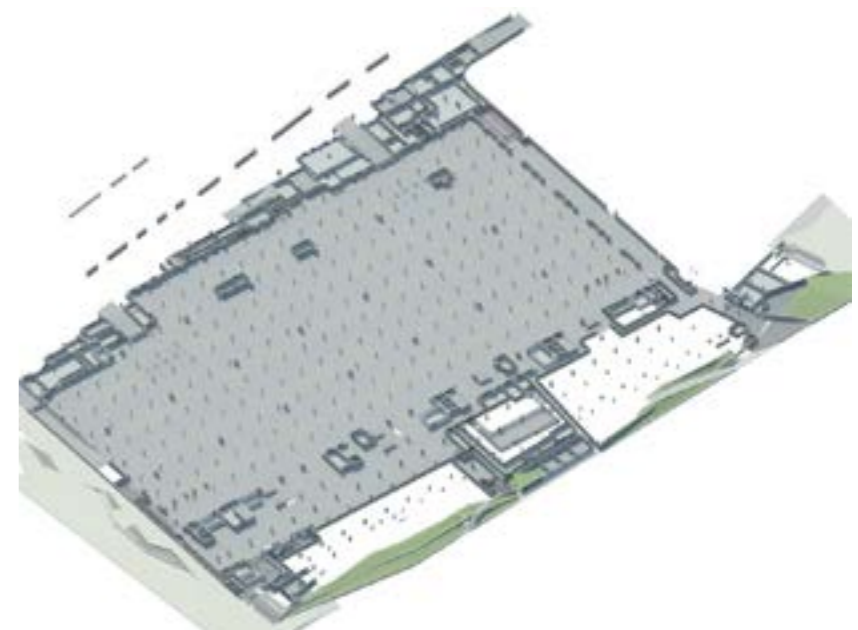

Axonometric cutaway view of Ground Level Exhibition Centre

LEGEND

- Lifts
- Fire hydrant
- Toilets / facilities
- Retail by others
- ♿ Accessible parking
- ⚡ Vehicle charging bay
- 🚲 Bicycle parking

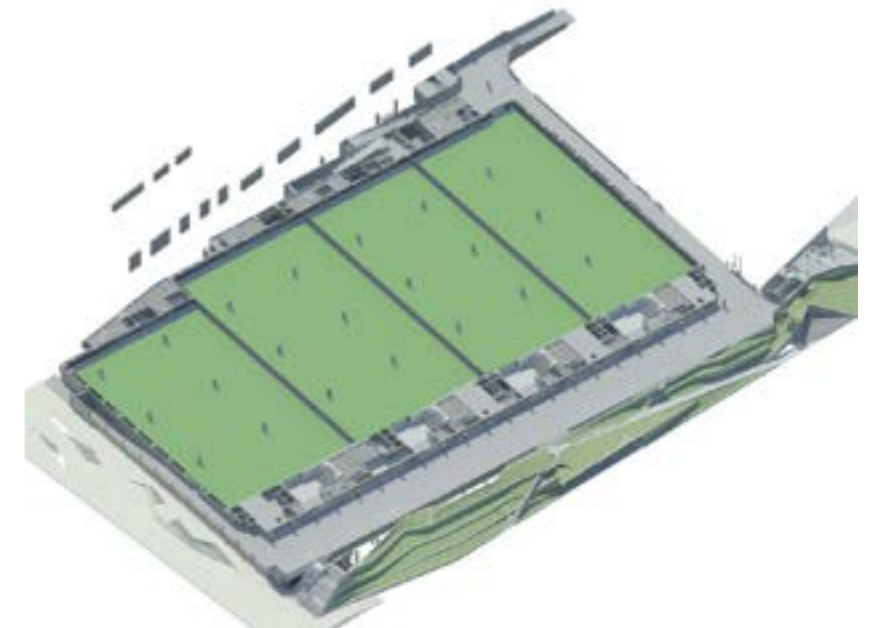

Axonometric cutaway view of Level 1 Exhibition Centre

LEGEND

- Circulation
- Lifts
- Fire Hydrants
- Toilets / Facilities
- Accessible Toilet
- Exhibition Halls
- Loading Dock
- Kiosk
- Exhibition Organizer's Office
- Columns at 27 metres centre

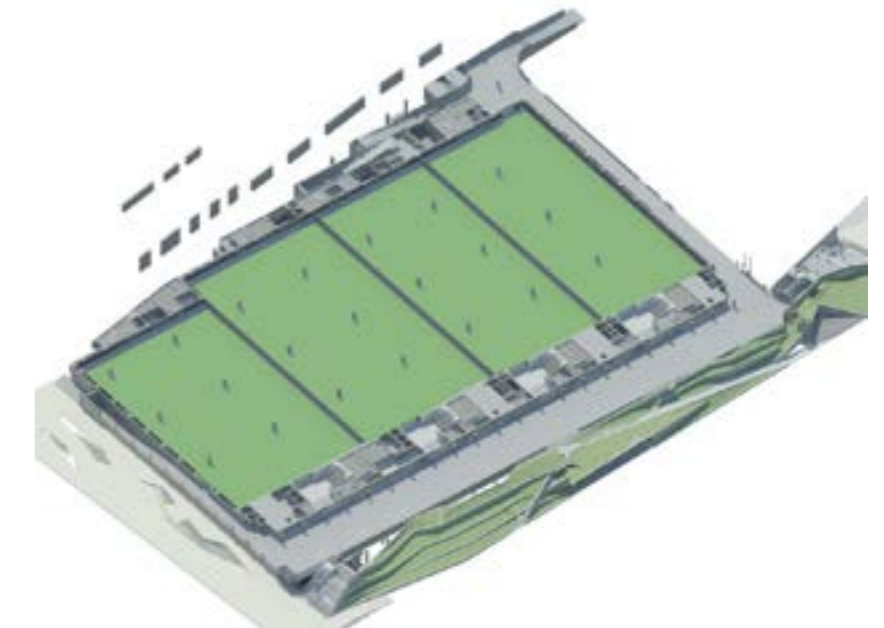

Axonometric cutaway view of Level 1 Exhibition Centre

1169 3m x 3m booths shown

LEGEND

- Circulation
- Lifts
- Fire Hydrants
- Toilets / Facilities
- Accessible Toilet
- Loading Dock
- Kiosk
- Exhibition Organizer's Office
- Columns at 27 metres centre
- No Build Zone
- No Build Catering
- Emergency Exit
- Water and drainage connection pit
- Trench
- Trench + Compressed Air
- Power Lock (each power lock, east and west, shares 400A between lower and upper halls)
- Service Pit Type 1
1 x SGPO
1 x 32A 3PH
1 x SINGLE DATA
1 x 2C SMOF
- Service Pit Type 2
1 x SGPO
1 x 32A 3PH

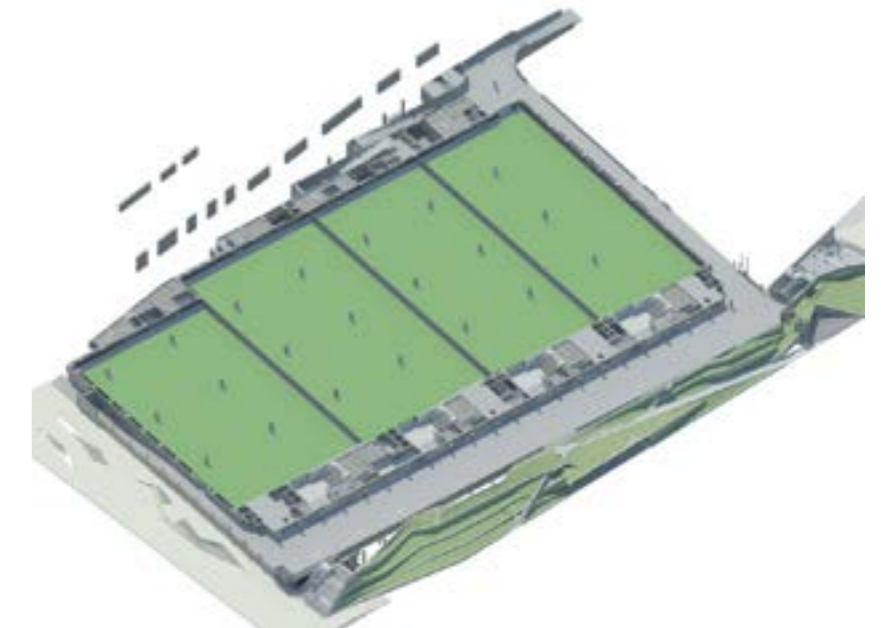
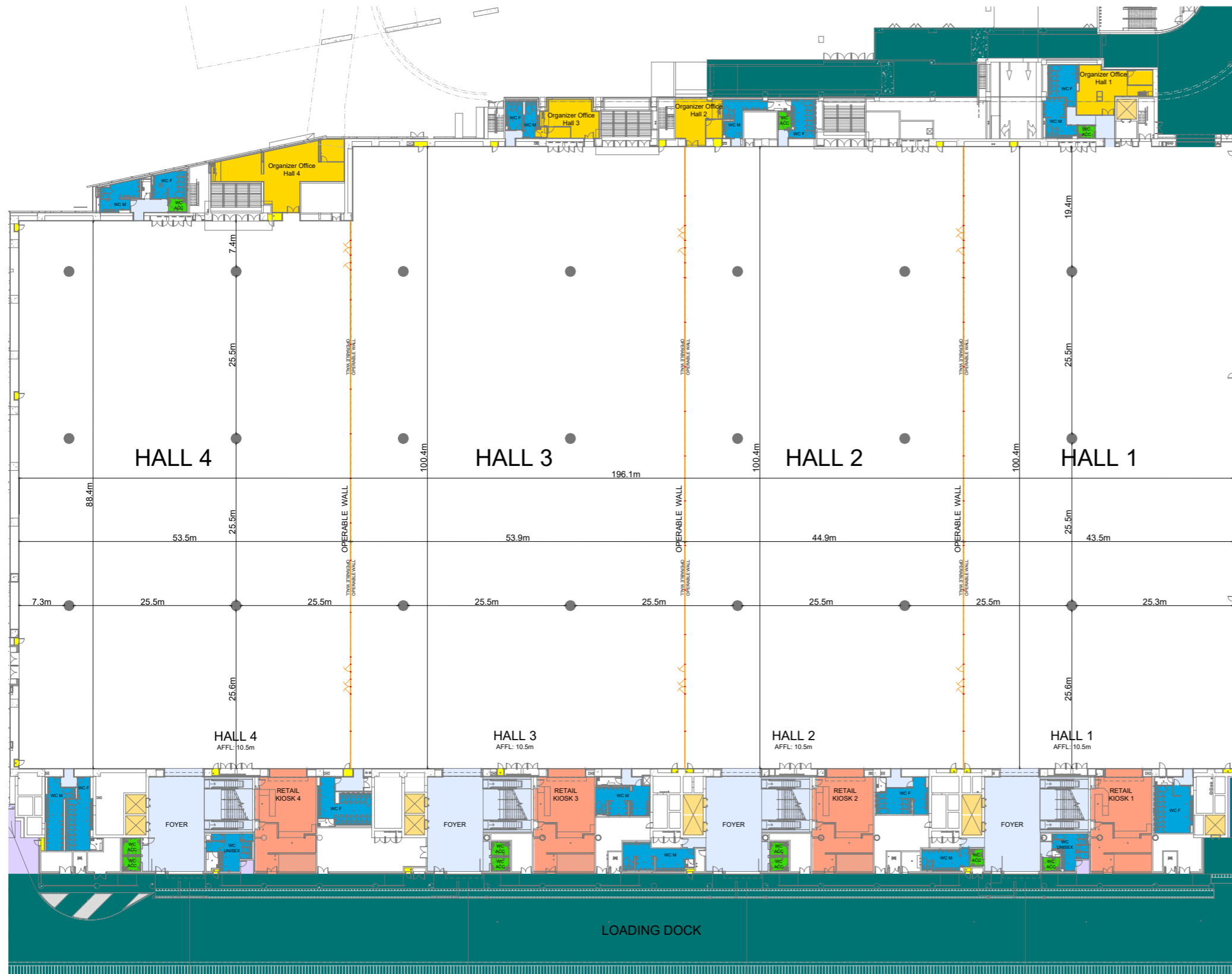

Axonometric cutaway view of Level 1 Exhibition Centre

LEGEND

- Circulation
- Lifts
- Fire Hydrants
- Toilets / Facilities
- Accessible Toilet
- Loading Dock
- Kiosk
- Exhibition Organizer's Office
- Columns at 27 metres centre

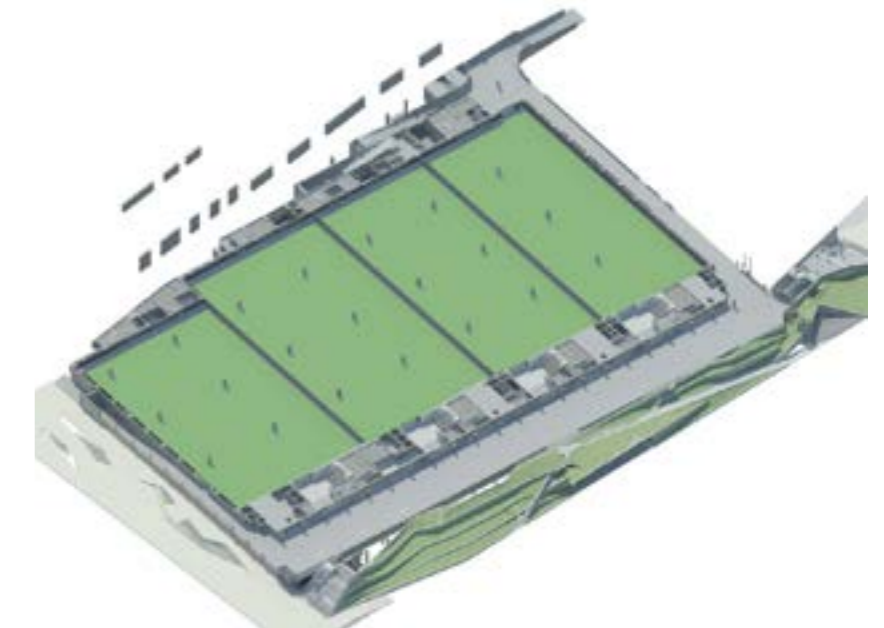

Axonometric cutaway view of Level 1 Exhibition Centre

LEGEND

- Circulation
- Lifts
- Fire Hydrants
- Toilets / Facilities
- Accessible Toilet
- Loading Dock
- Kiosk
- Exhibition Organizer's Office
- Columns at 27 metres centre
- +
 Water and drainage connection pit
- Trench
- Trench + Compressed Air
- Power Lock (each power lock, east and west, shares 400A between lower and upper halls)
- Service Pit Type 1
 1 x SGPO
 1 x 32A 3PH
 1 x SINGLE DATA
 1 x 2C SMOF
- Service Pit Type 2
 1 x SGPO
 1 x 32A 3PH

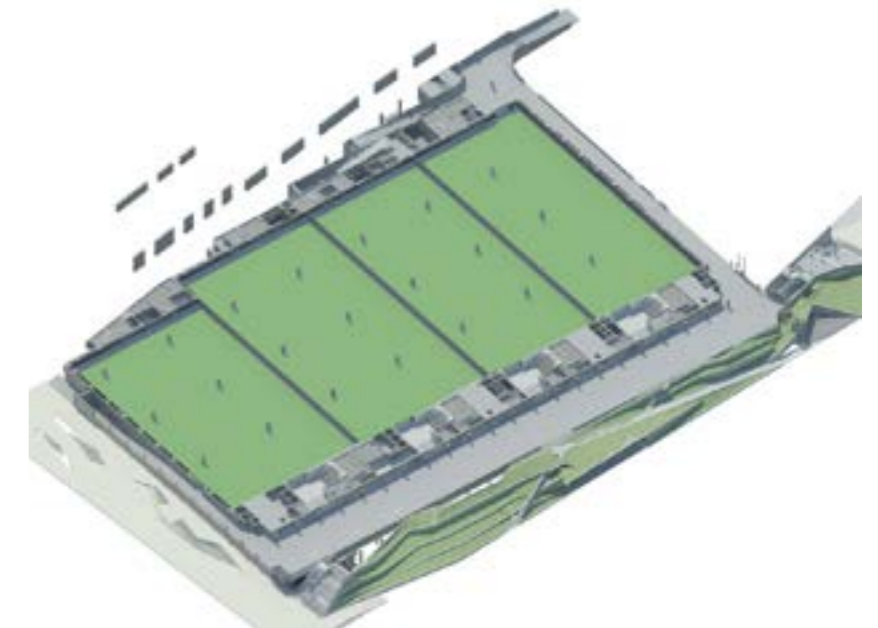

Axonometric cutaway view of Level 1 Exhibition Centre

LEGEND

- Circulation
- Lifts
- Fire Hydrants
- Toilets / Facilities
- Accessible Toilet
- Loading Dock
- Kiosk
- Exhibition Organizer's Office
- Columns at 27 metres centre
- X Rigging Point 2.5T

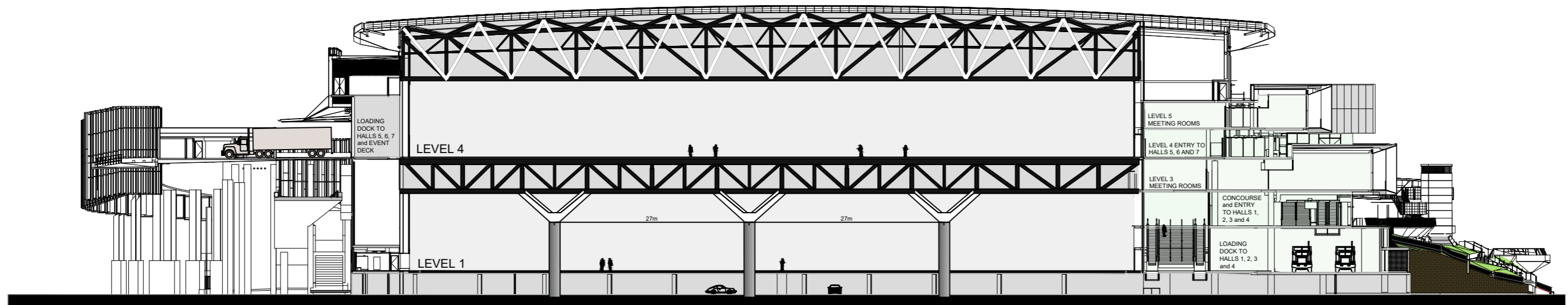

GROUND LEVEL - CAR PARK

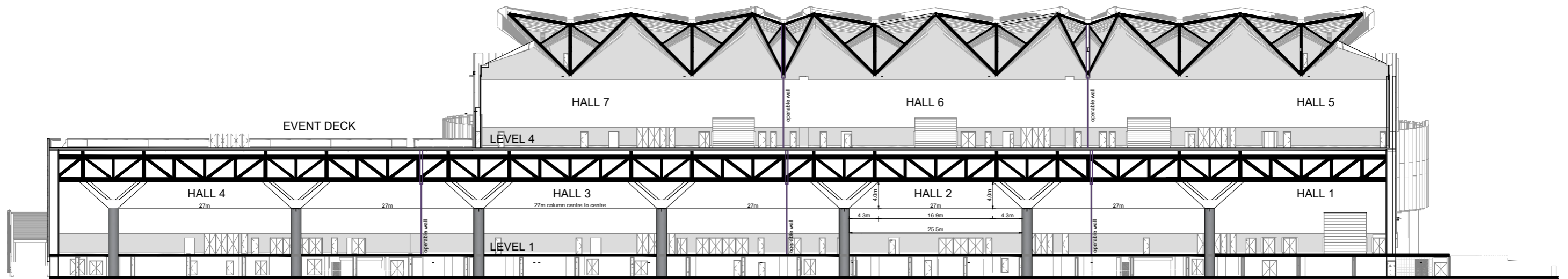

GROUND LEVEL - CAR PARK

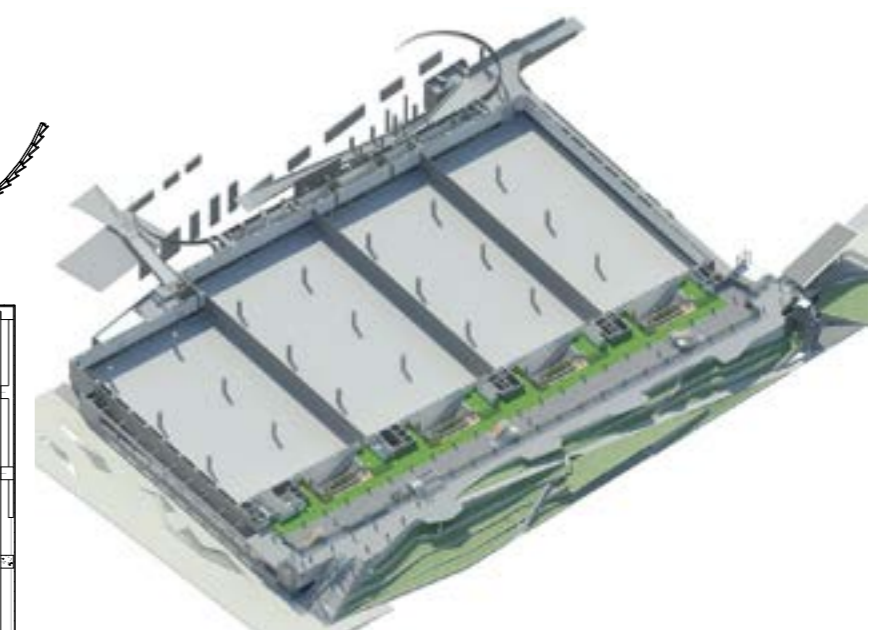
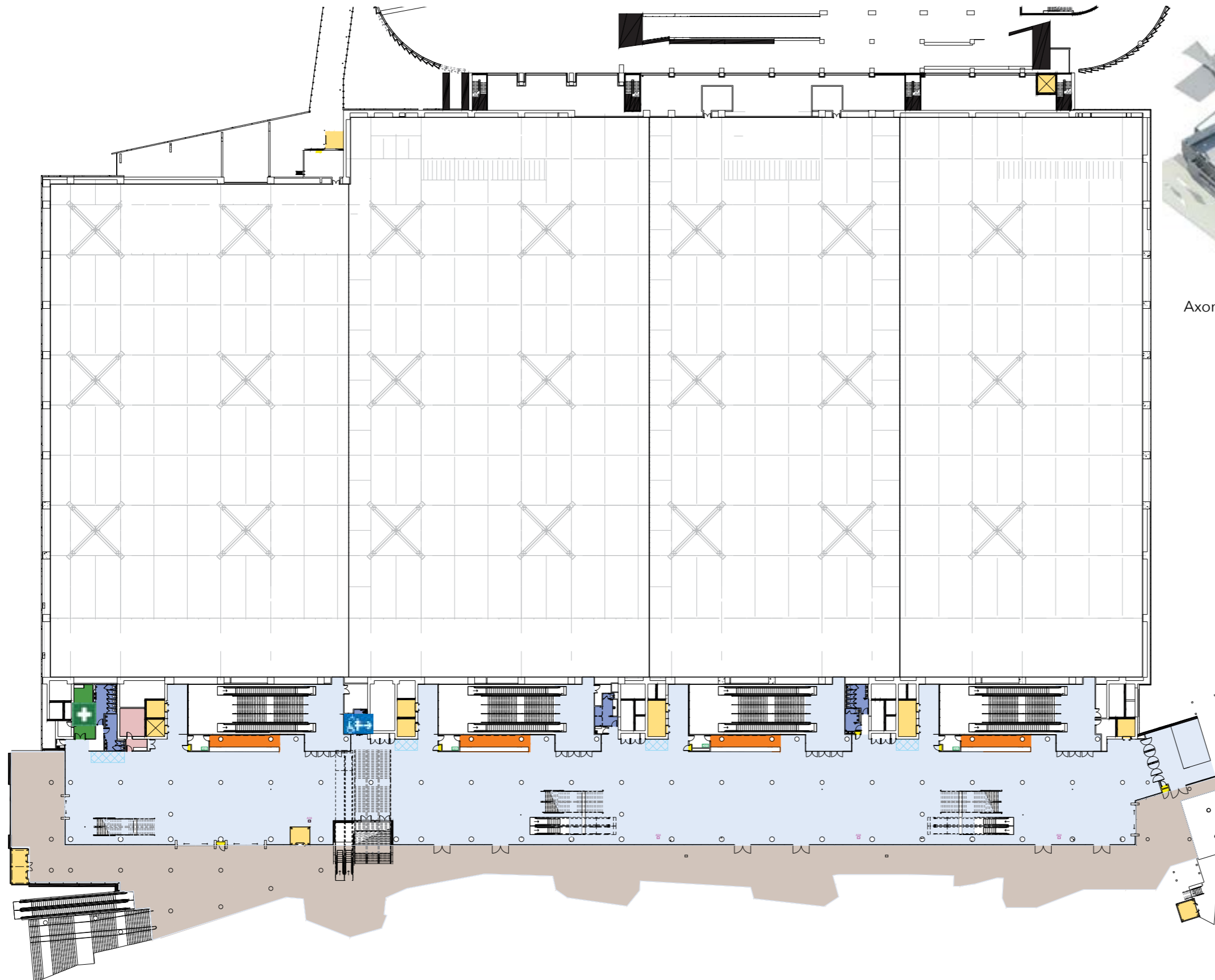

Axonometric cutaway view of Level 2 Exhibition Centre

LEGEND

- Circulation Front of House
- Lifts
- Fire hydrant
- Toilets / facilities
- First Aid
- Registration Counter
- Cloak Room
- Changing places

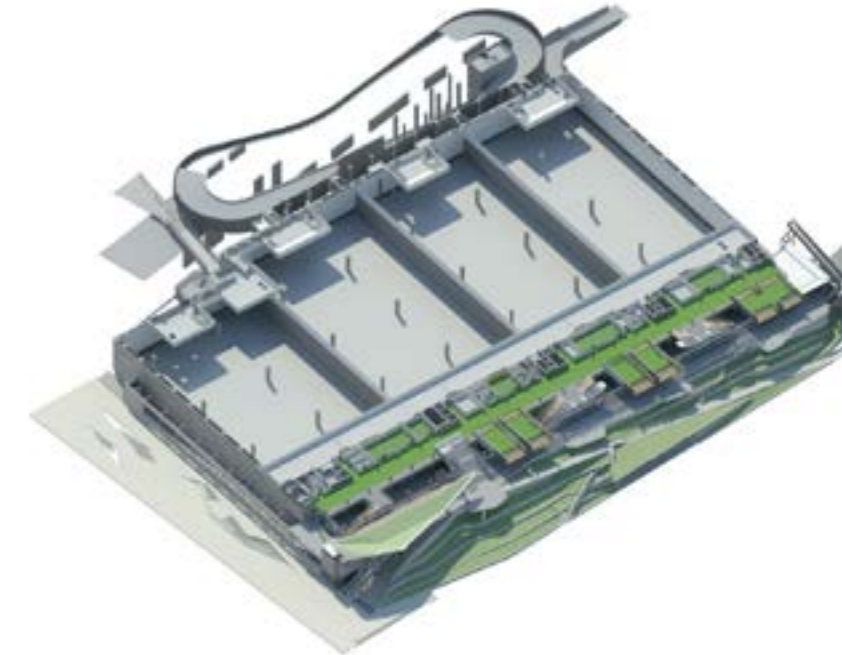
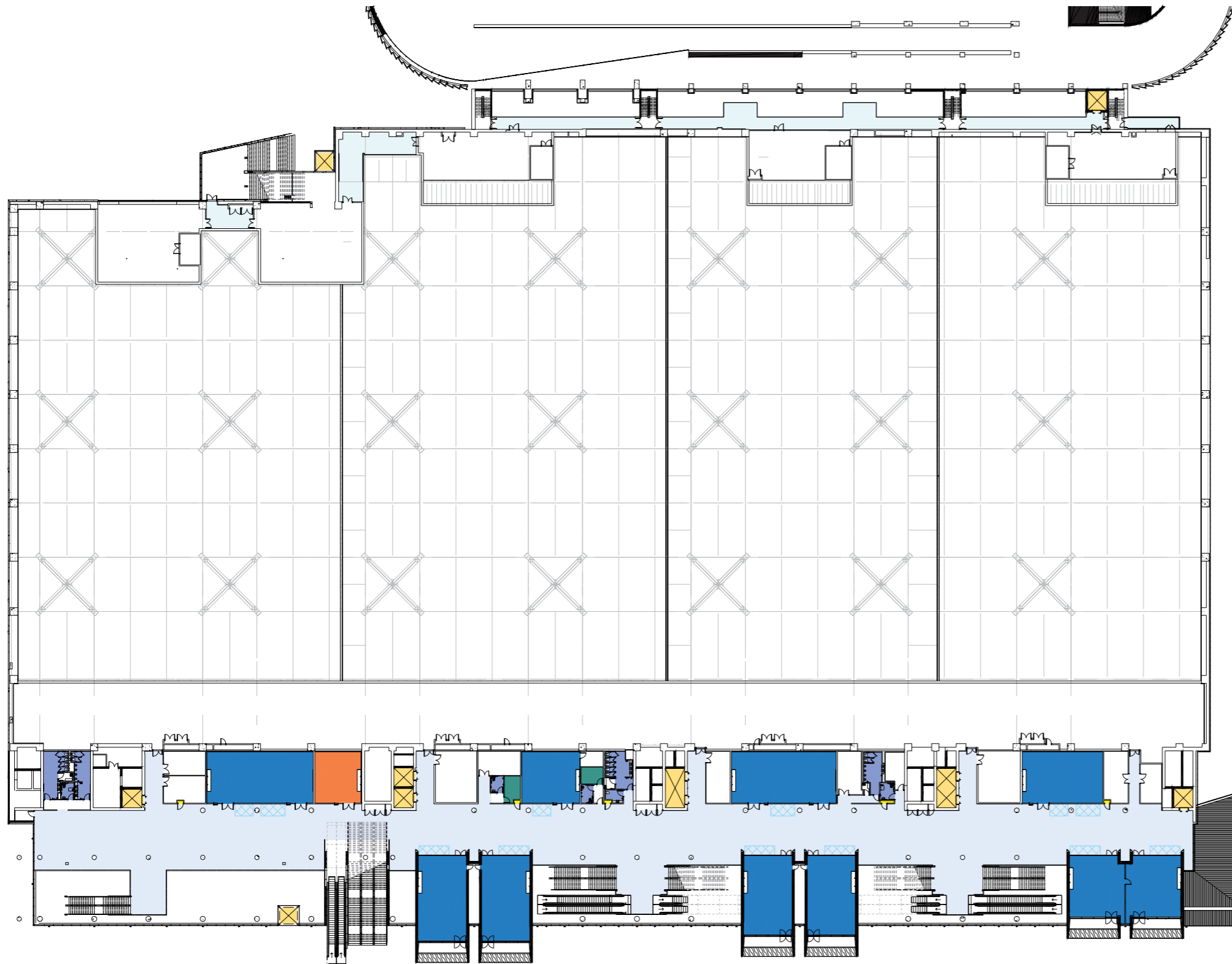

Axonometric cutaway view of Level 3 Exhibition Centre

LEGEND

- Circulation Front of house
- Circulation Back of house
- Lifts
- Fire hydrant
- Toilets / facilities
- Business Suite 3
- Prayer Rooms
- Public Space Build Zone

LEGEND

- Circulation Front of house
- Circulation Back of house
- Lifts
- Fire hydrant
- Toilets / facilities
- Business Suite 3
- Prayer Rooms
- Public Space Build Zone
- Rigging Point 1.0T
- Rigging Bar 100kg/lm

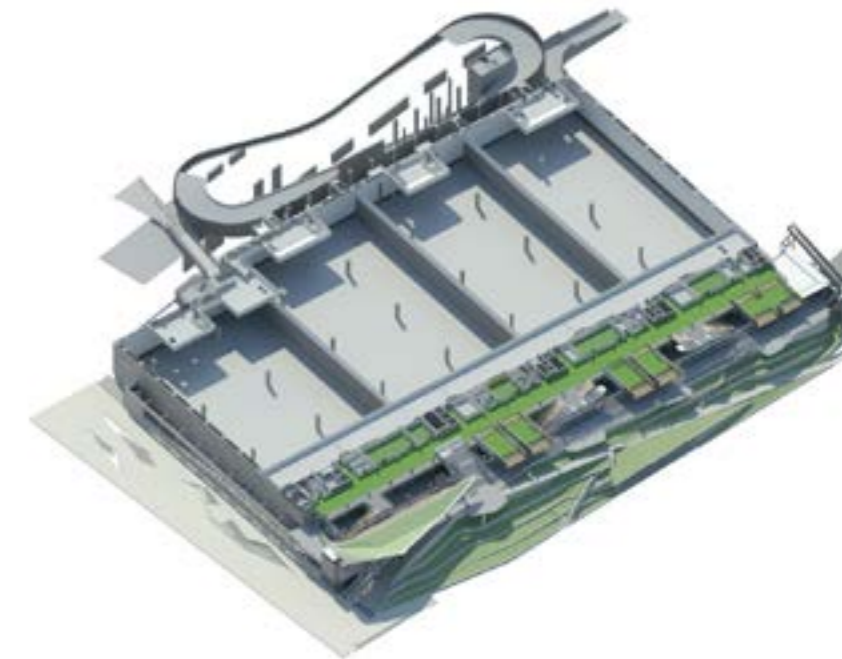

Axonometric cutaway view of Level 3 Exhibition Centre

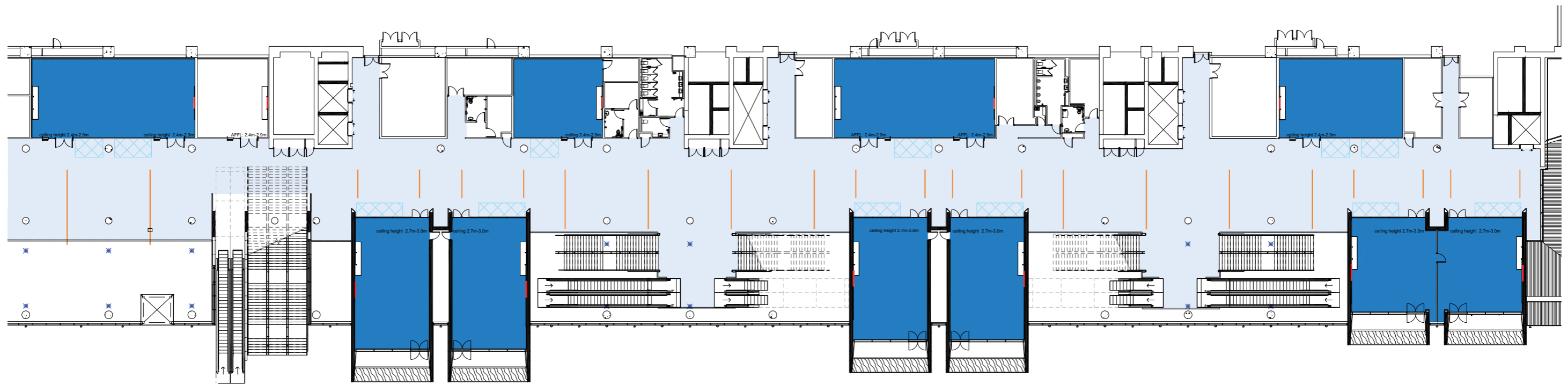

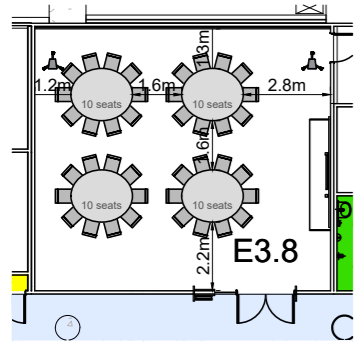

E3.8

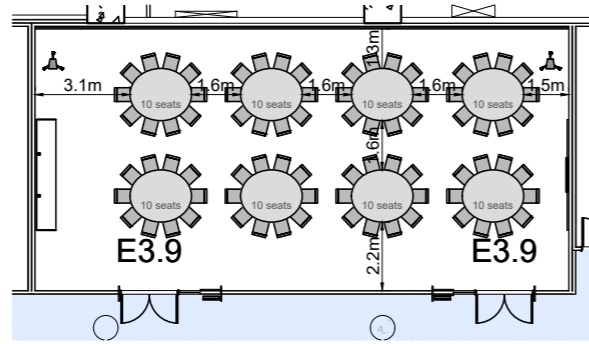

E3.9

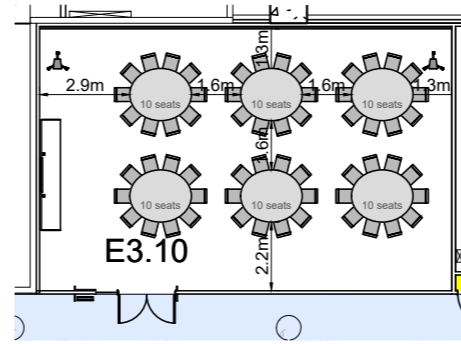

E3.10

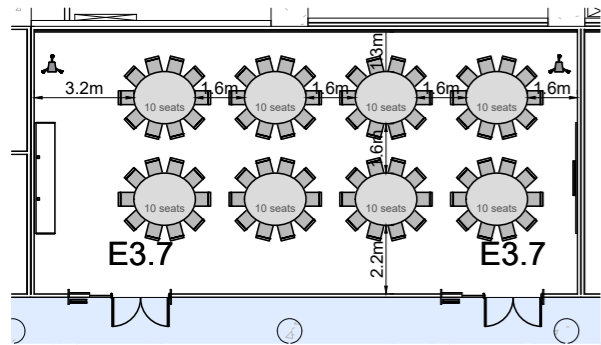

E3.7

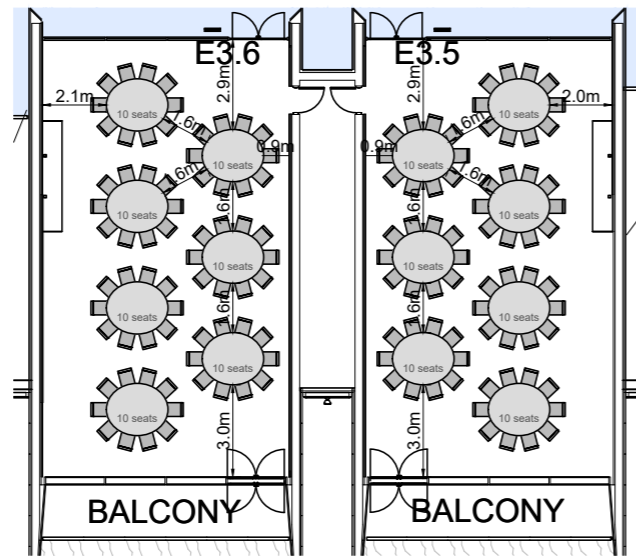

E3.6

E3.5

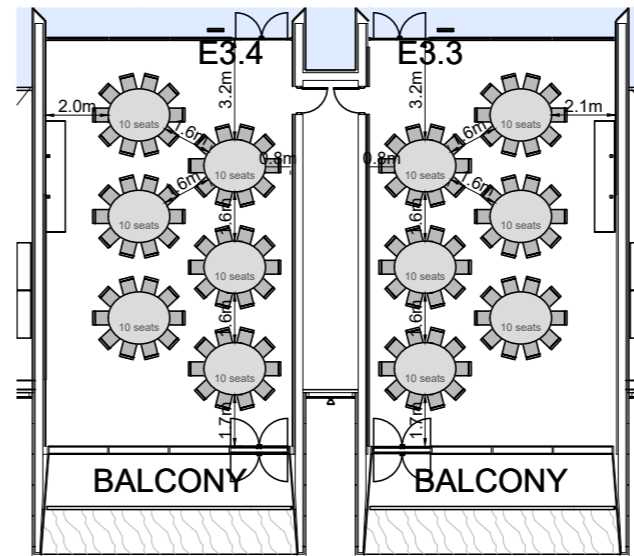

E3.4

E3.3

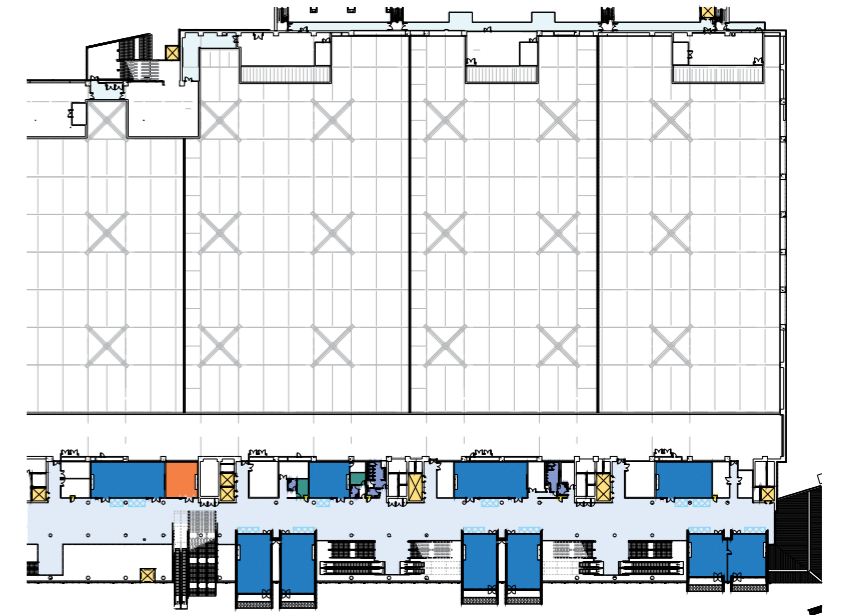

Level 3 Exhibition Centre

LEGEND

- Circulation Front of house
- Public Space Build Zone

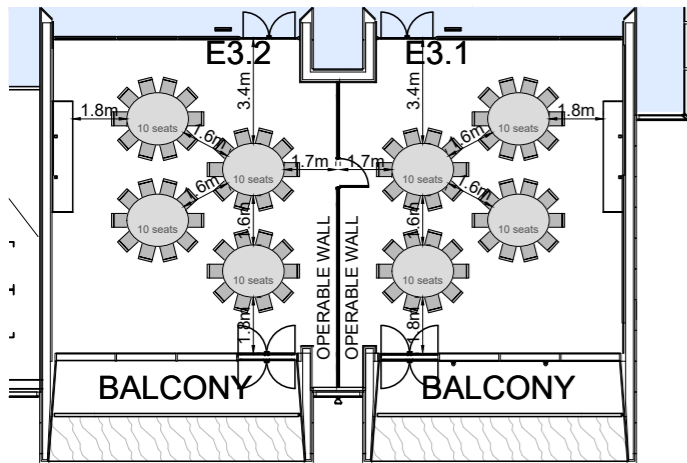

E3.2

E3.1

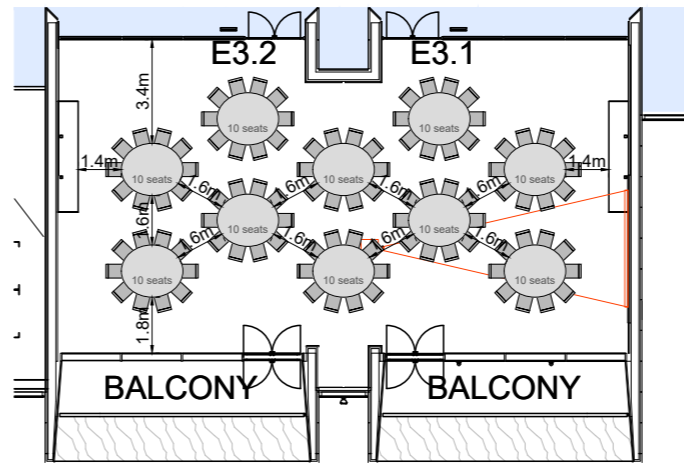

E3.1+E3.2 COMBINED

ROOM NAME	BANQUET
MEETING ROOM E3.1	40
MEETING ROOM E3.2	40
MEETING ROOM E3.1 & E3.2	100
MEETING ROOM E3.3	60
MEETING ROOM E3.4	60
MEETING ROOM E3.5	70
MEETING ROOM E3.6	70
MEETING ROOM E3.7	80
MEETING ROOM E3.8	40
MEETING ROOM E3.9	80
MEETING ROOM E3.10	60

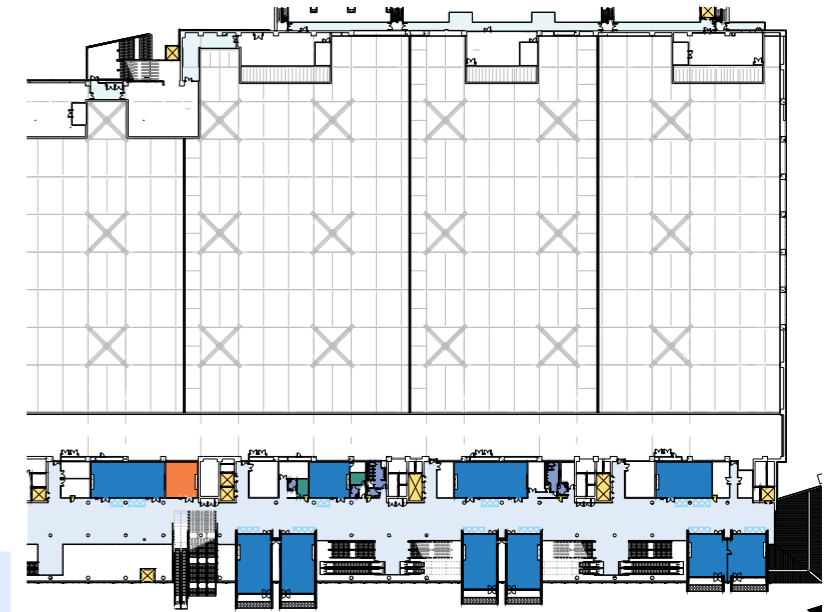
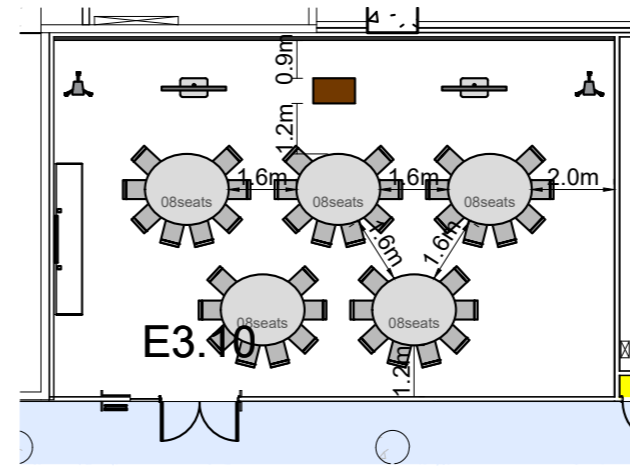
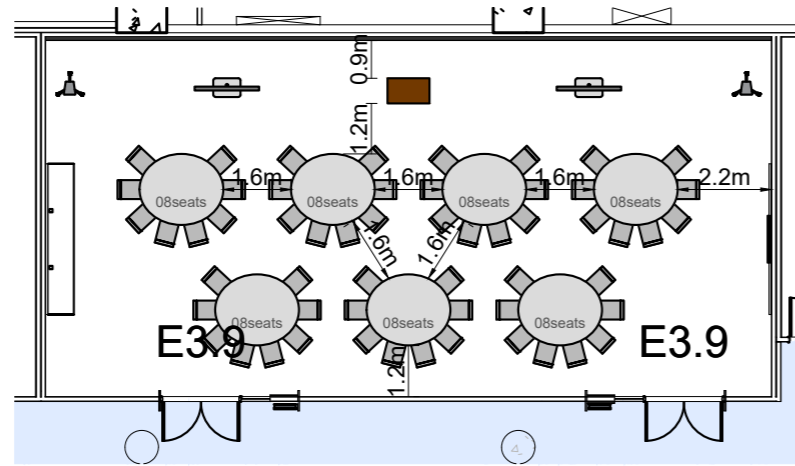
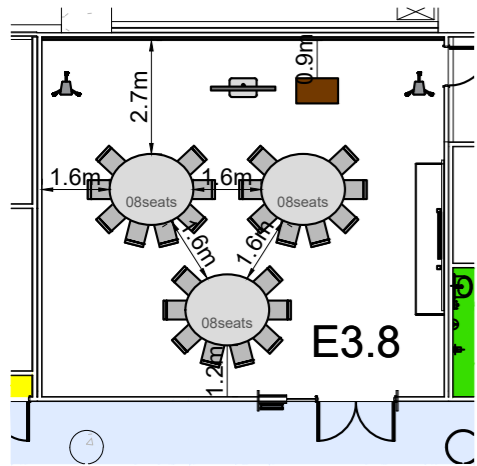

Level 3 Exhibition Centre

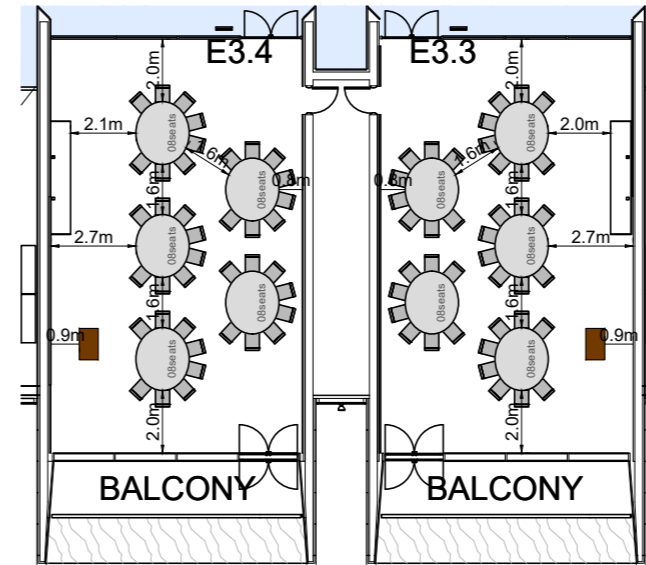
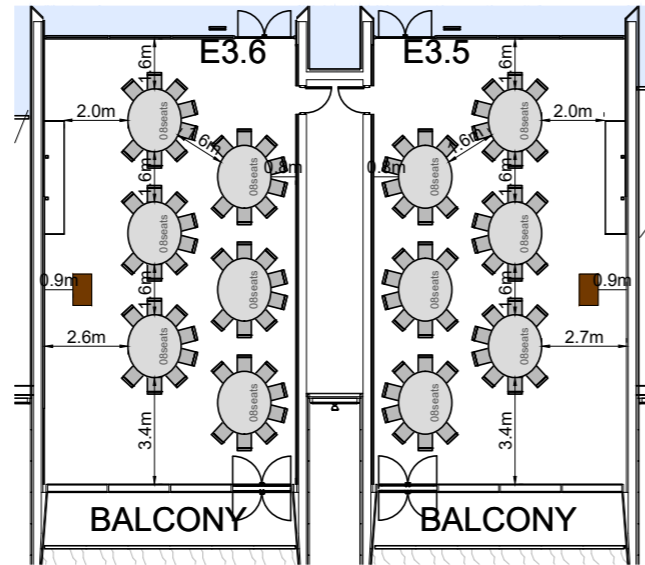
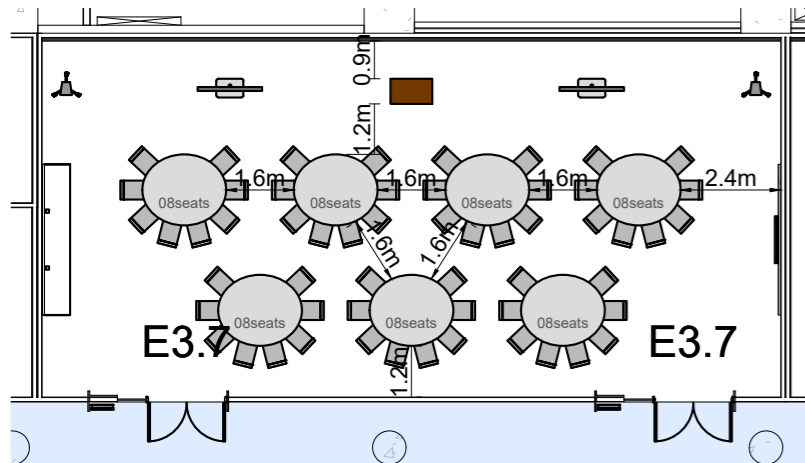

LEGEND

- Circulation Front of house
- Public Space Build Zone

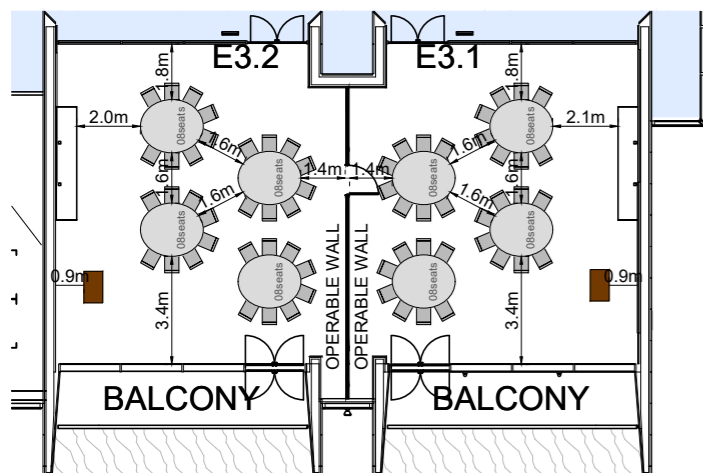

* Standard capacity illustrated. Higher capacities can be achieved with less staging and AV services and reduced furniture spacing. Please consider your event requirements when viewing capacities.

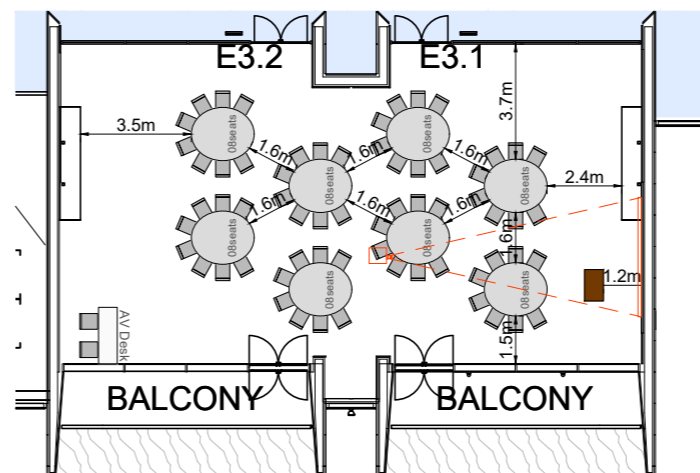

ROOM NAME	CABARET
MEETING ROOM E3.1	32
MEETING ROOM E3.2	32
MEETING ROOM E3.1 & E3.2	64
MEETING ROOM E3.3	40
MEETING ROOM E3.4	40
MEETING ROOM E3.5	48
MEETING ROOM E3.6	48
MEETING ROOM E3.7	56
MEETING ROOM E3.8	24
MEETING ROOM E3.9	56
MEETING ROOM E3.10	40

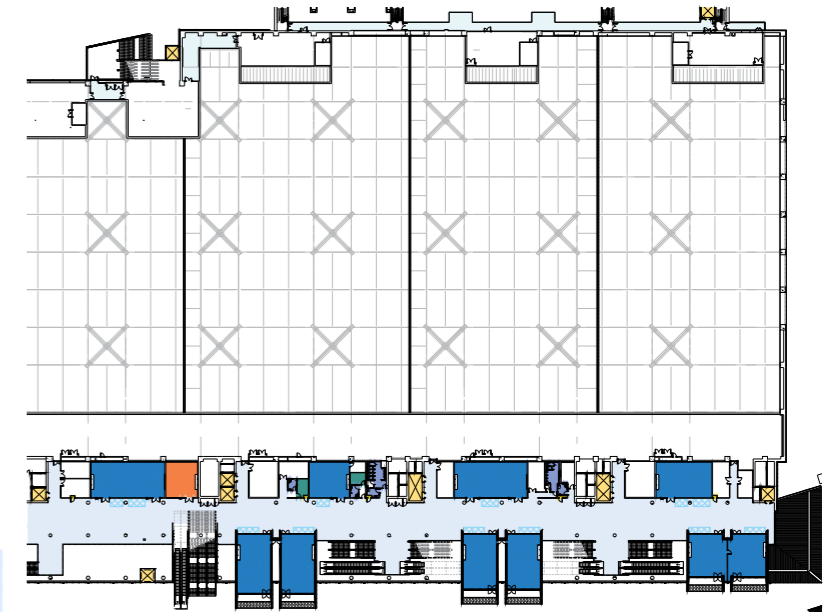
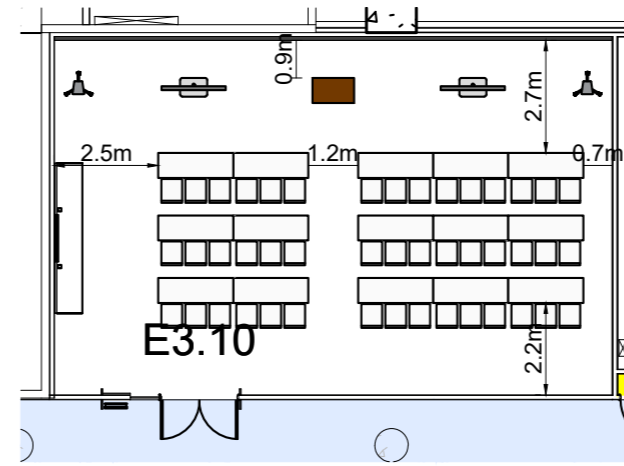
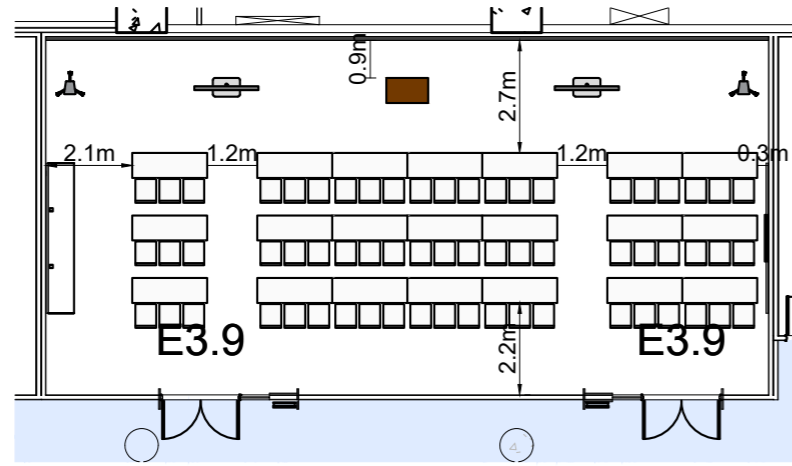
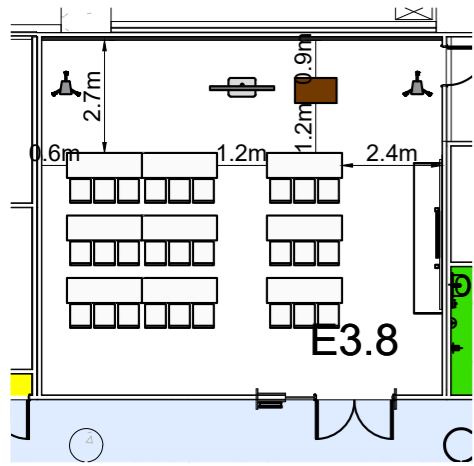

Level 3 Exhibition Centre

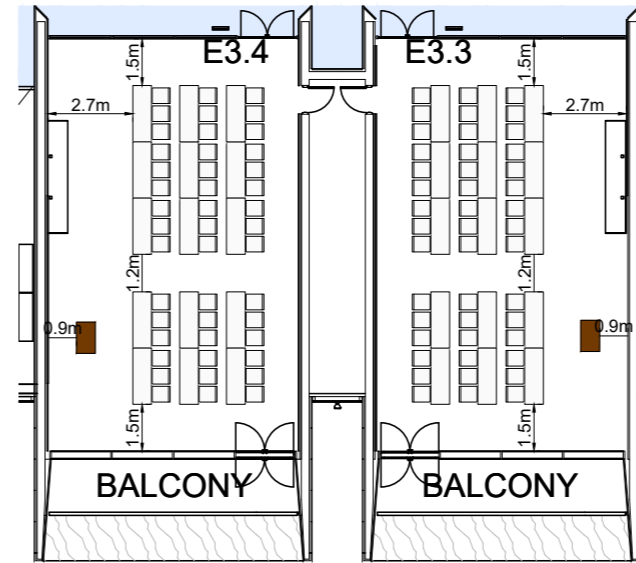
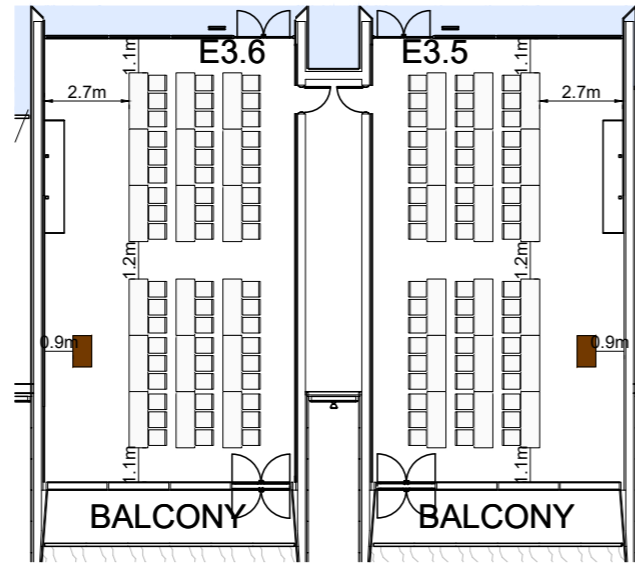
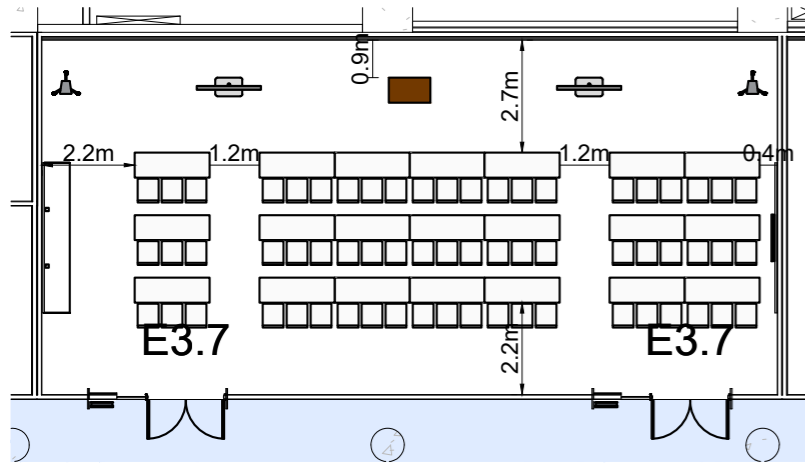

LEGEND

- Circulation Front of house
- Public Space Build Zone

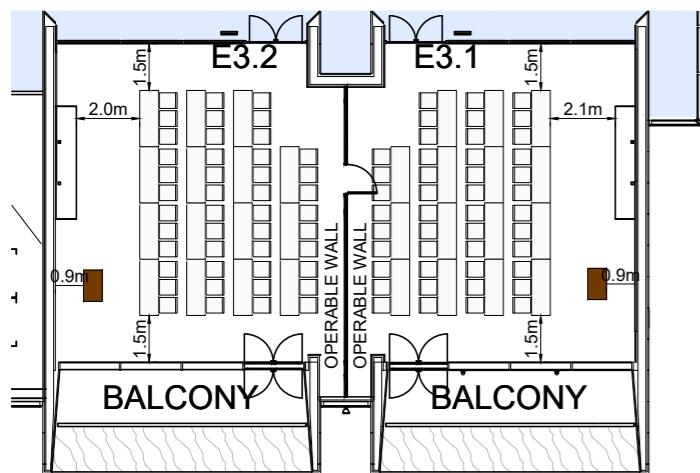

* Standard capacity illustrated. Higher capacities can be achieved with less staging and AV services and reduced furniture spacing. Please consider your event requirements when viewing capacities.

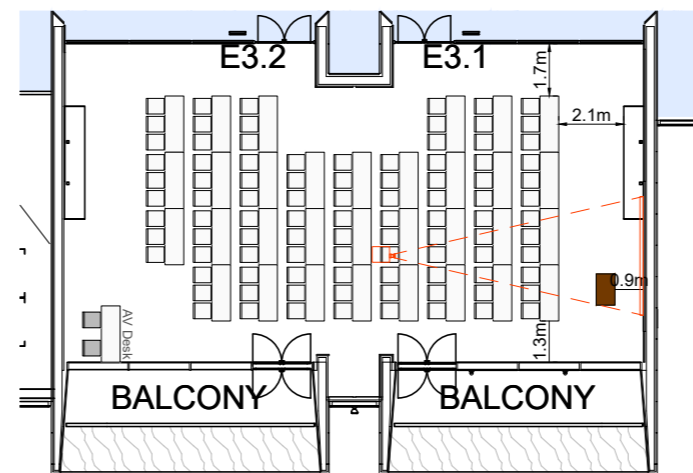

ROOM NAME	CLASSROOM
MEETING ROOM E3.1	45
MEETING ROOM E3.2	45
MEETING ROOM E3.1 & E3.2	96
MEETING ROOM E3.3	45
MEETING ROOM E3.4	45
MEETING ROOM E3.5	54
MEETING ROOM E3.6	54
MEETING ROOM E3.7	63
MEETING ROOM E3.8	27
MEETING ROOM E3.9	63
MEETING ROOM E3.10	45

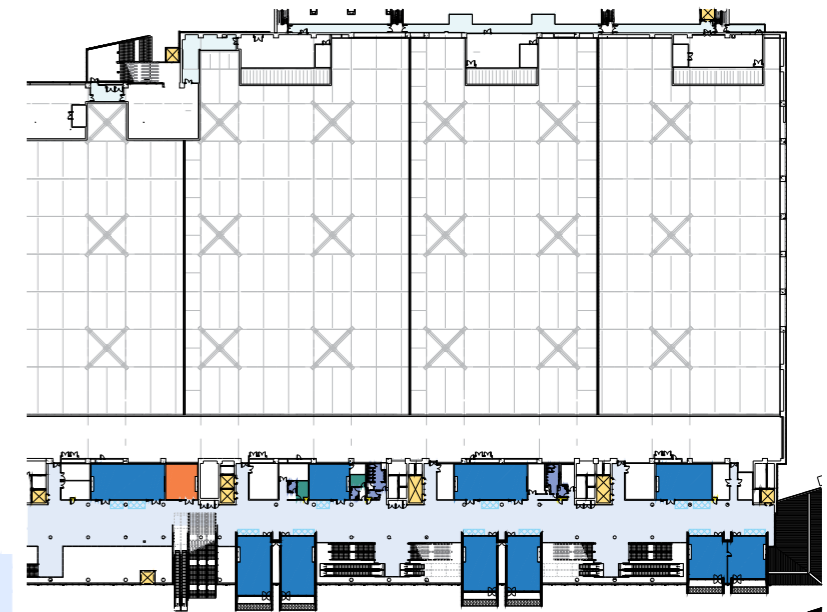
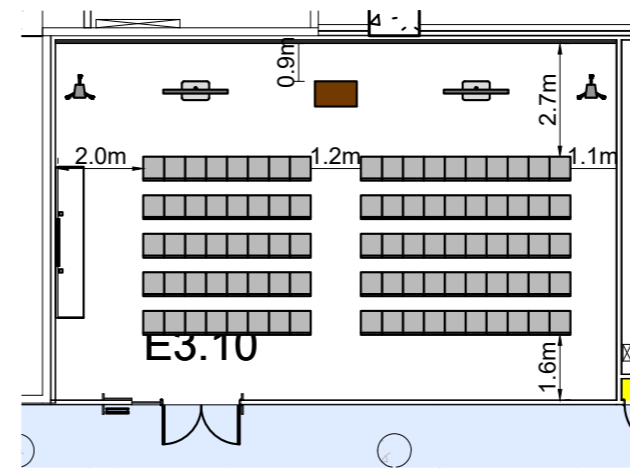
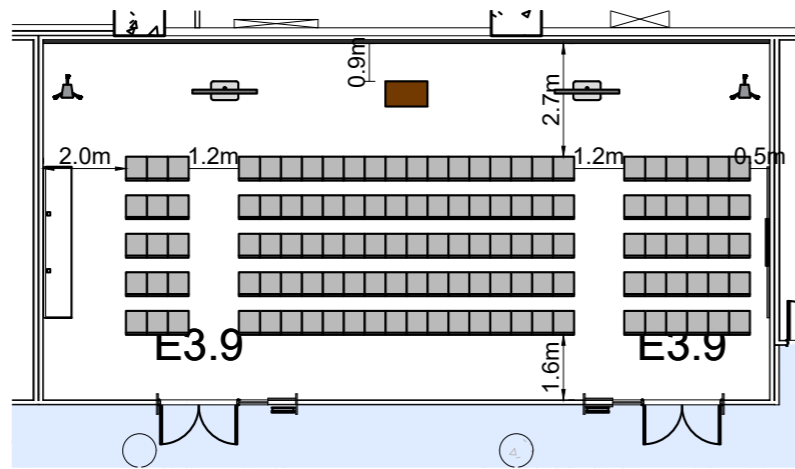
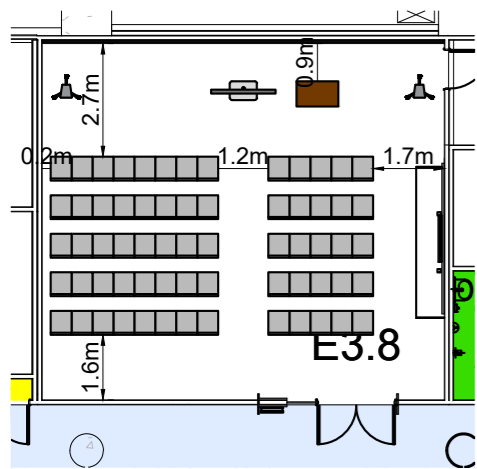

Level 3 Exhibition Centre

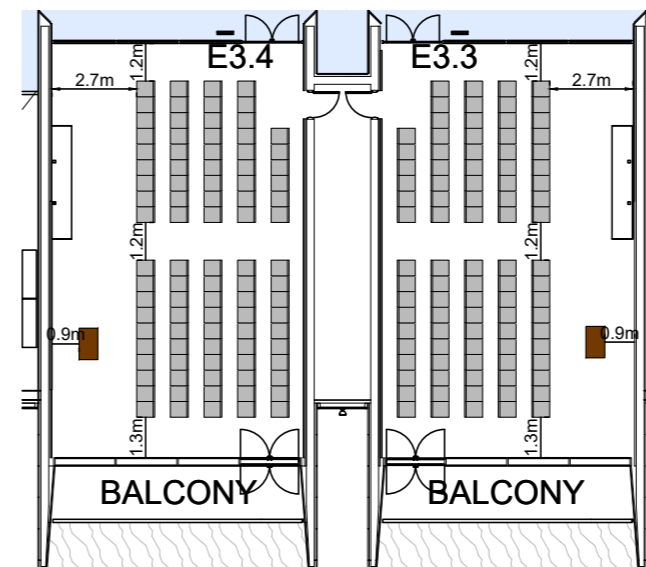
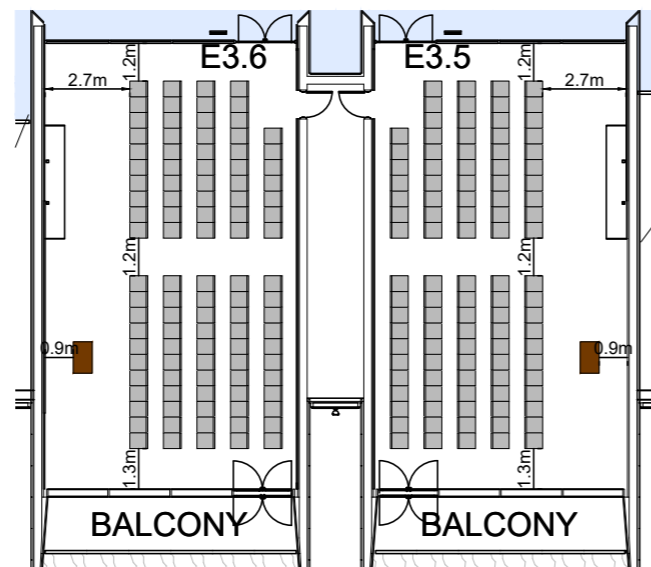
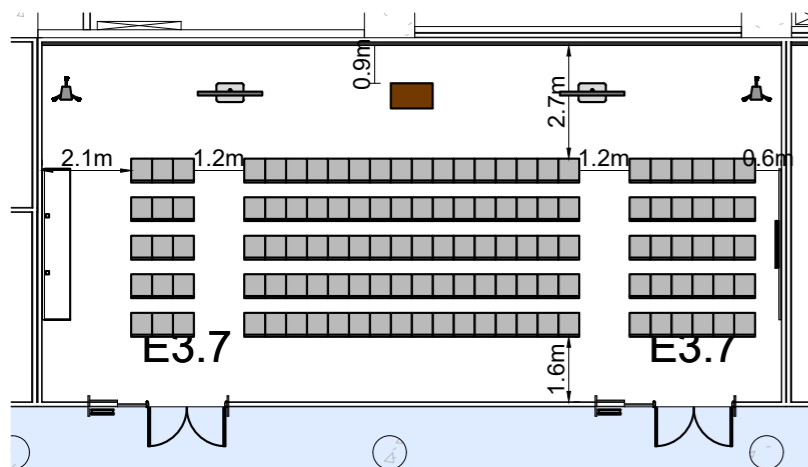

LEGEND

- Circulation Front of house
- Public Space Build Zone

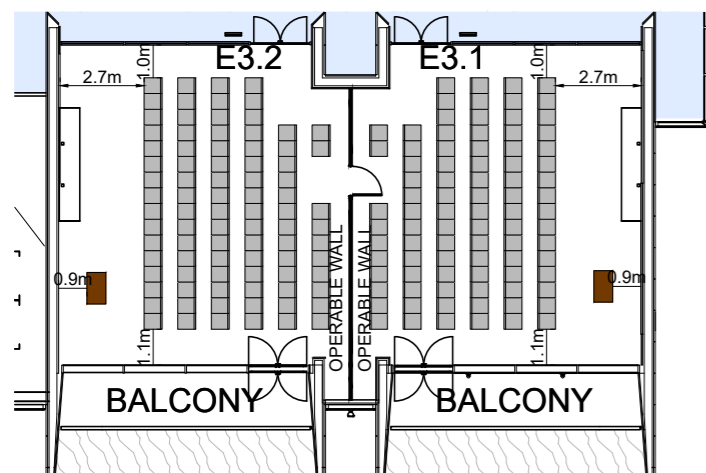

* Standard capacity illustrated. Higher capacities can be achieved with less staging and AV services and reduced furniture spacing. Please consider your event requirements when viewing capacities.

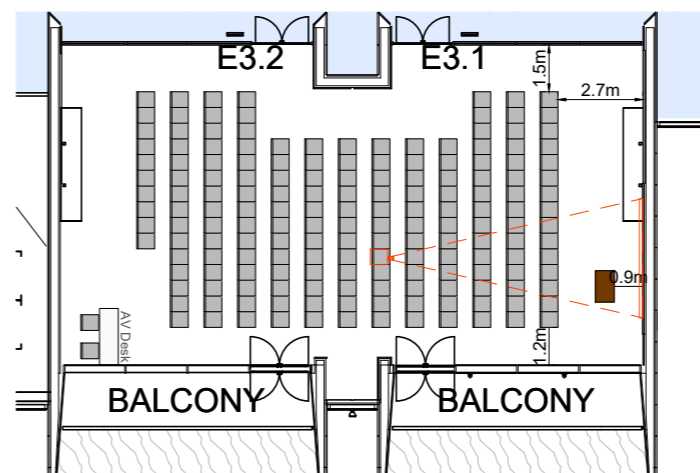

ROOM NAME	THEATRE
MEETING ROOM E3.1	89
MEETING ROOM E3.2	89
MEETING ROOM E3.1 & E3.2	172
MEETING ROOM E3.3	92
MEETING ROOM E3.4	92
MEETING ROOM E3.5	102
MEETING ROOM E3.6	102
MEETING ROOM E3.7	125
MEETING ROOM E3.8	65
MEETING ROOM E3.9	125
MEETING ROOM E3.10	90

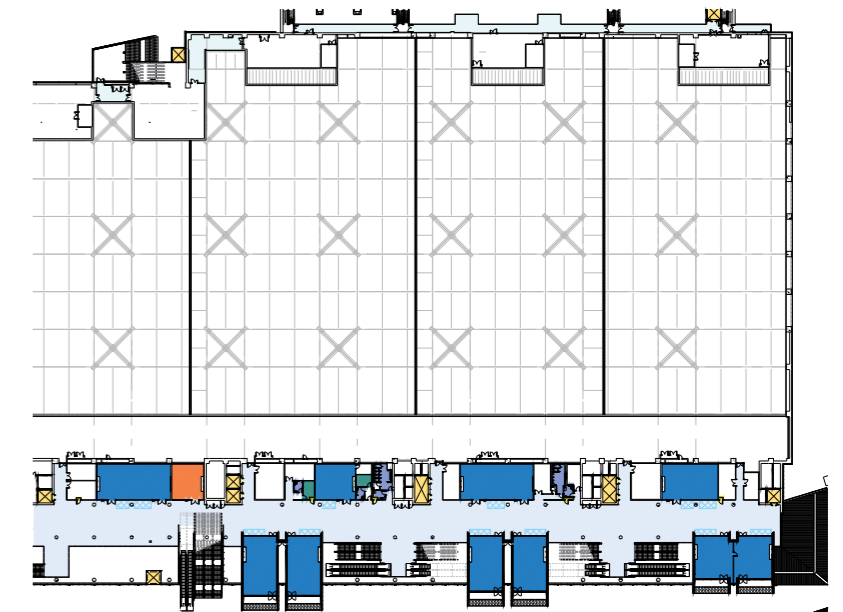
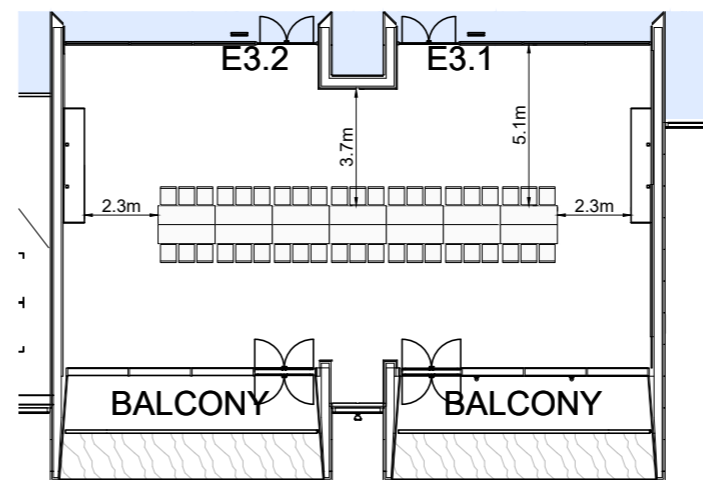
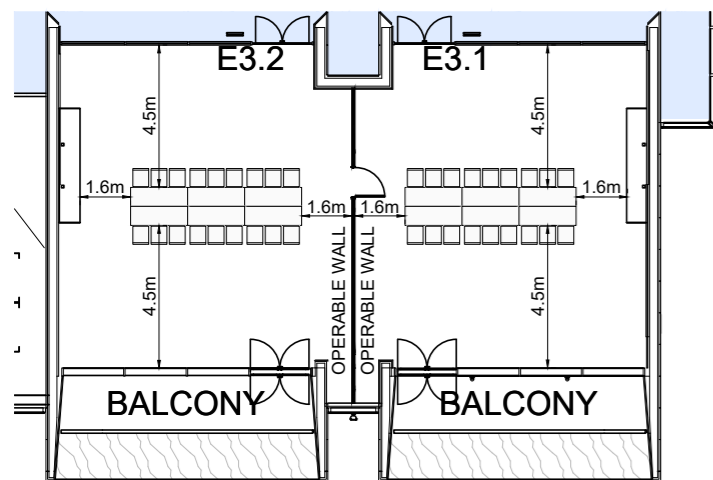
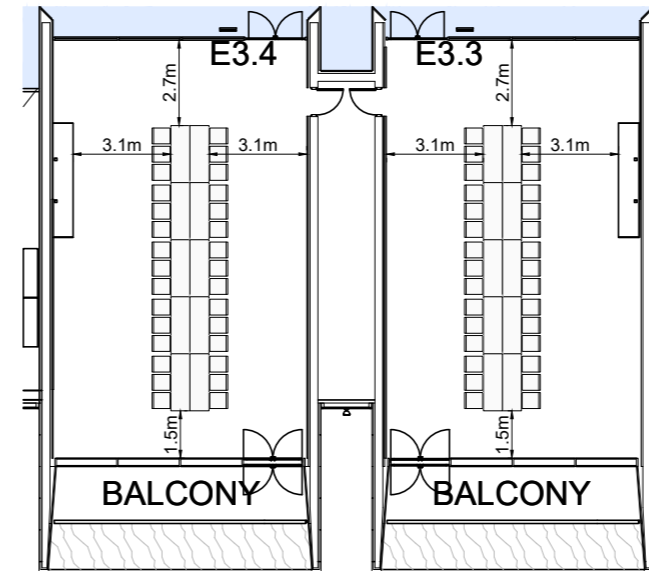
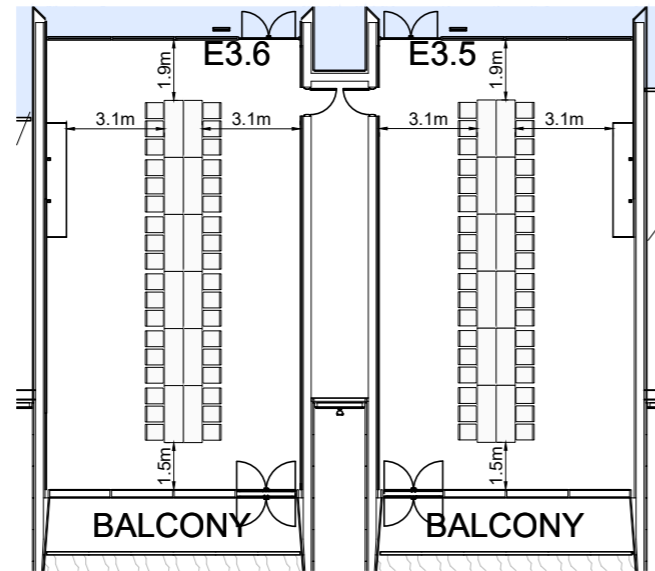
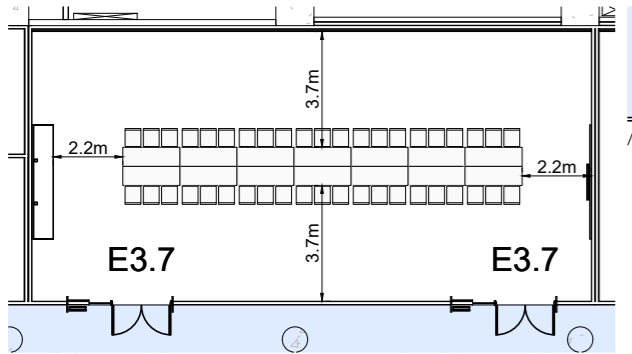
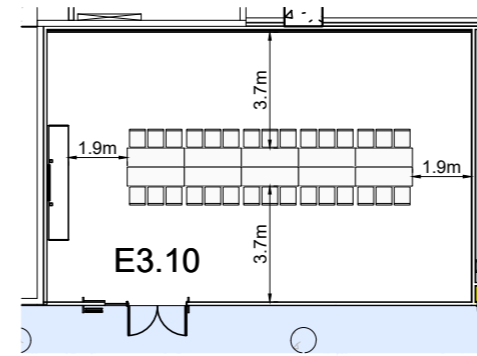
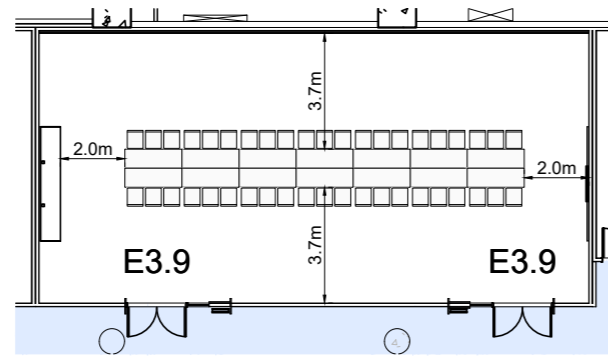
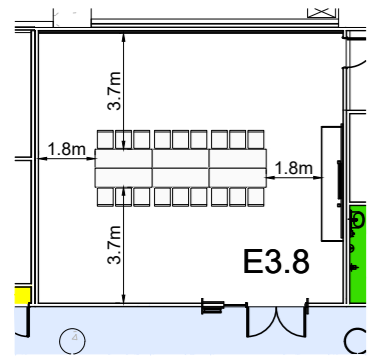

Level 3 Exhibition Centre

LEGEND

- Circulation Front of house
- Public Space Build Zone

ROOM NAME	BOARDROOM
MEETING ROOM E3.1	18
MEETING ROOM E3.2	18
MEETING ROOM E3.1 & E3.2	42
MEETING ROOM E3.3	30
MEETING ROOM E3.4	30
MEETING ROOM E3.5	36
MEETING ROOM E3.6	36
MEETING ROOM E3.7	42
MEETING ROOM E3.8	18
MEETING ROOM E3.9	42
MEETING ROOM E3.10	30

Maximum Capacity illustrated.

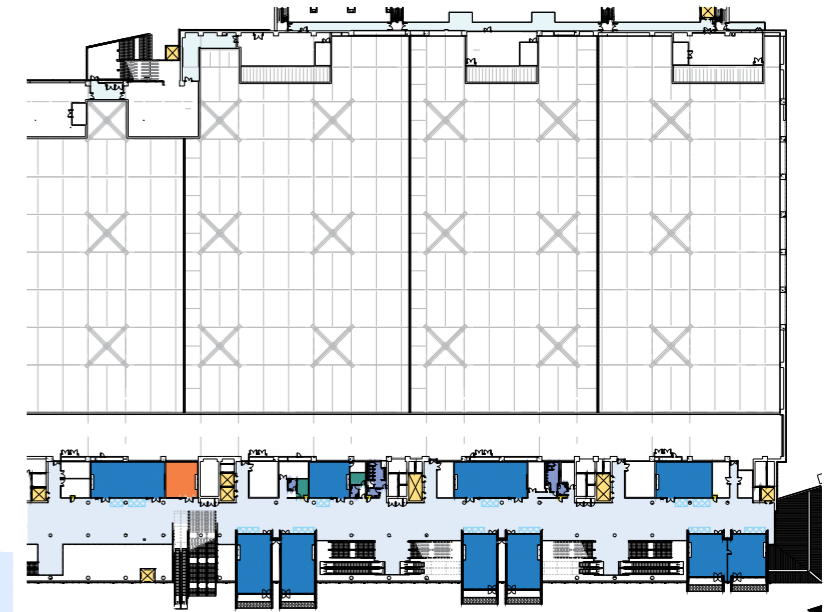
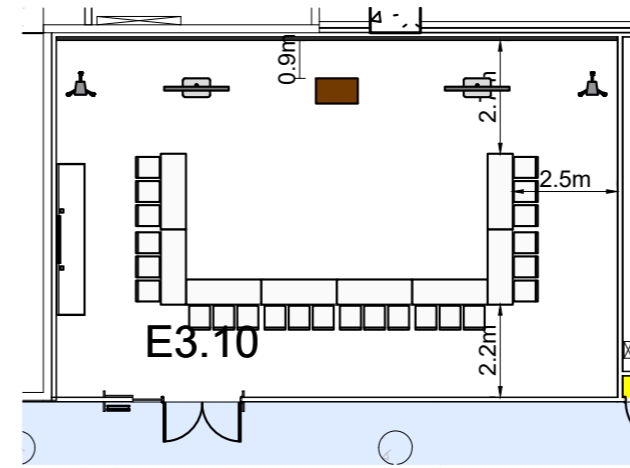
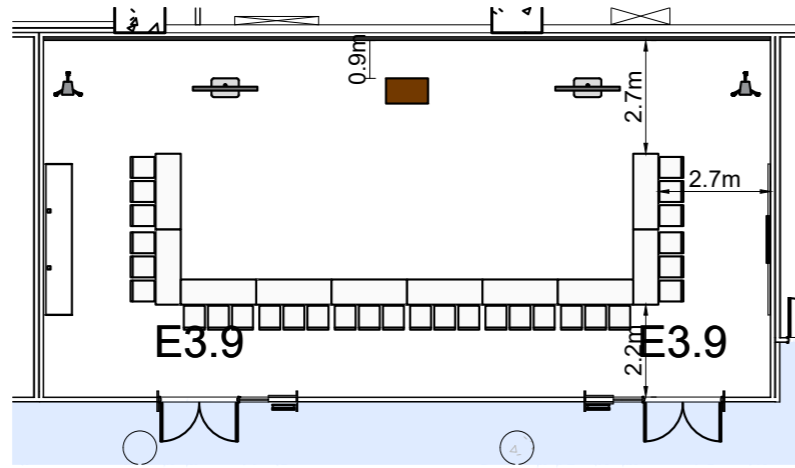
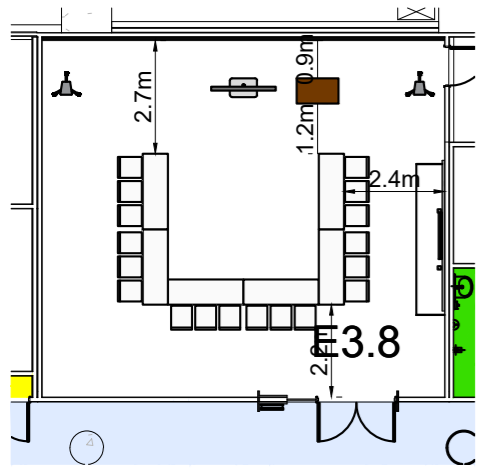

Level 3 Exhibition Centre

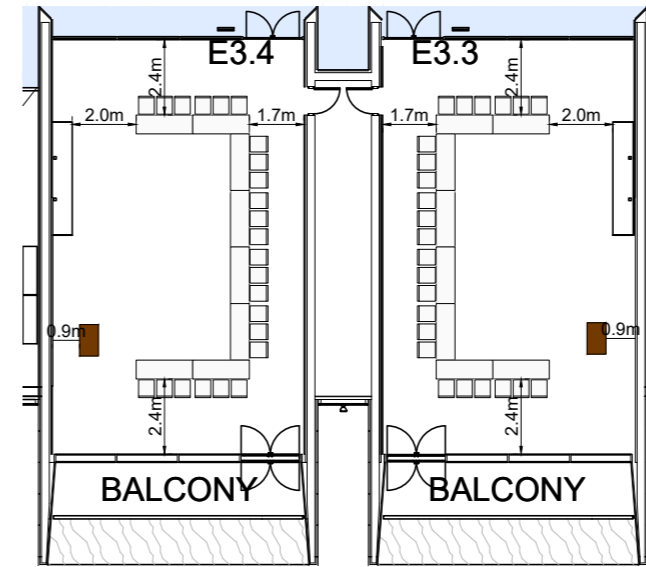
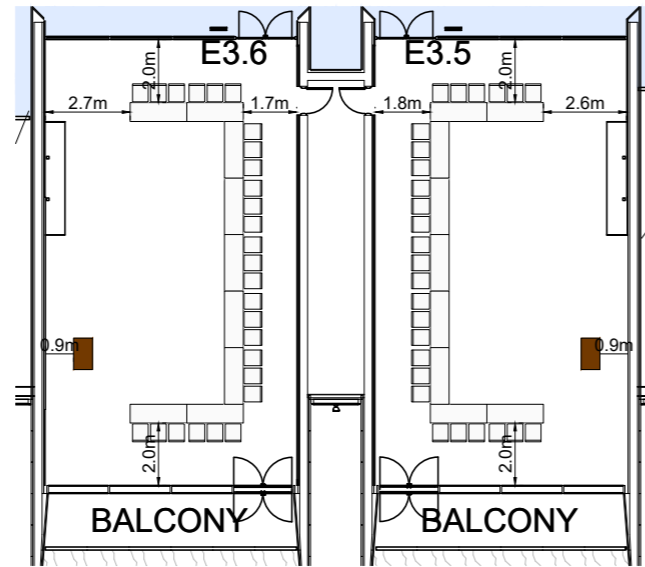
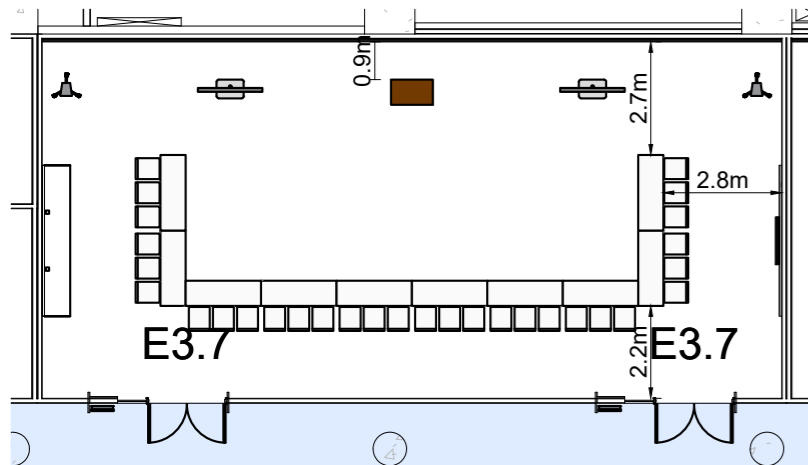

LEGEND

- Circulation Front of house
- Public Space Build Zone

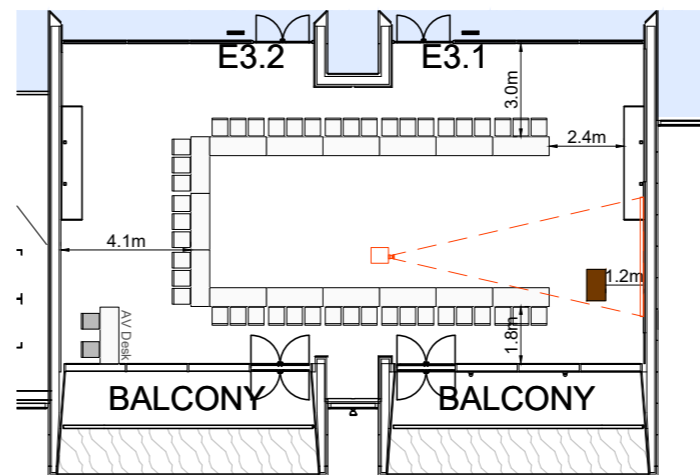
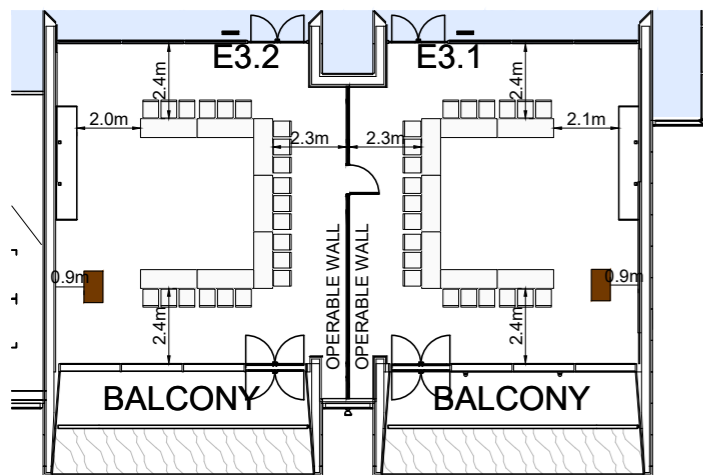

ROOM NAME	U SHAPE
MEETING ROOM E3.1	21
MEETING ROOM E3.2	21
MEETING ROOM E3.1 & E3.2	45
MEETING ROOM E3.3	24
MEETING ROOM E3.4	24
MEETING ROOM E3.5	27
MEETING ROOM E3.6	27
MEETING ROOM E3.7	30
MEETING ROOM E3.8	18
MEETING ROOM E3.9	30
MEETING ROOM E3.10	24

Maximum Capacity illustrated.

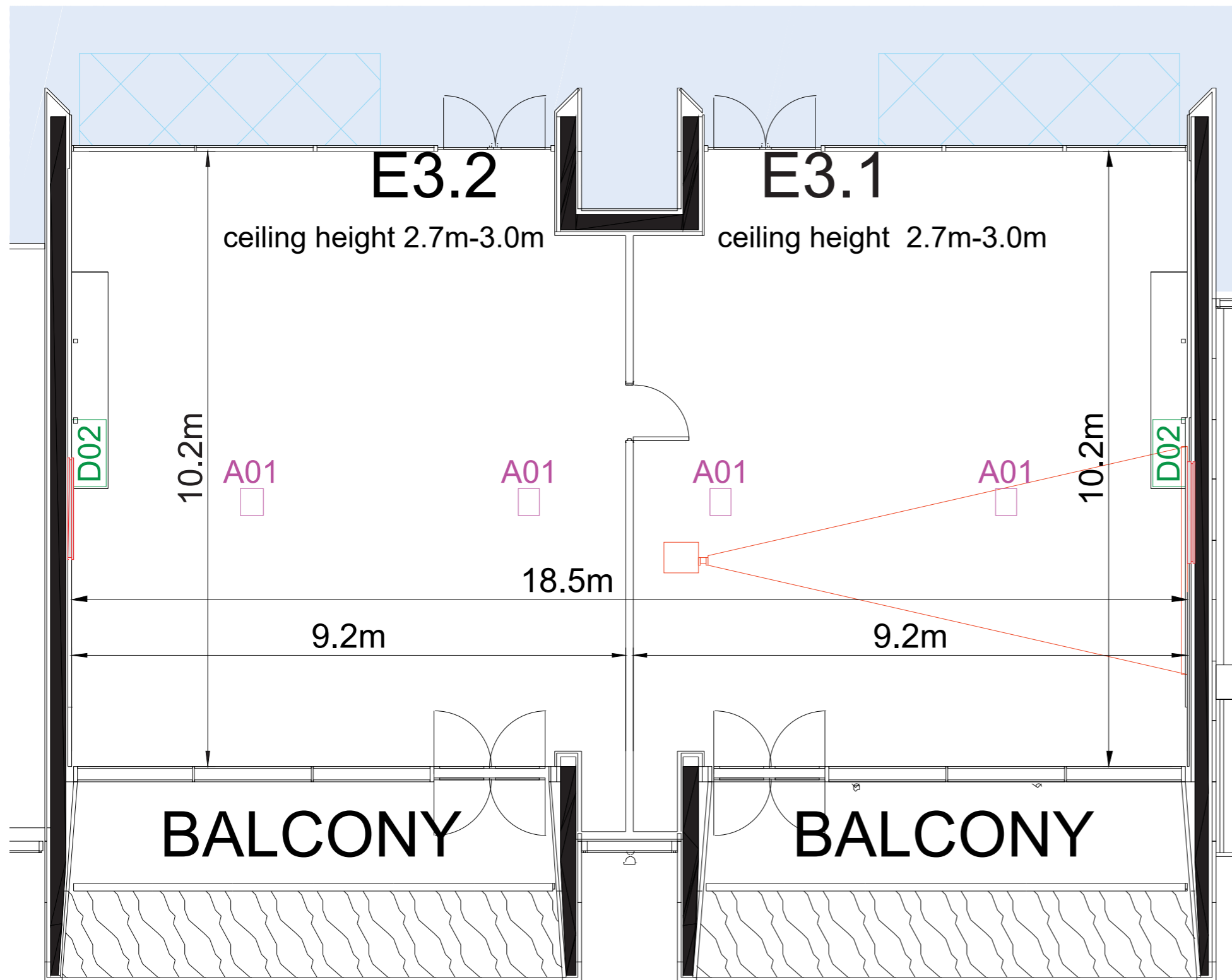

Level 3 Exhibition Centre

LEGEND

- **A01** Floor Box Type A01
6 x SGPO
2 x SINGLE DATA
- **A04** Floor Box Type A04
3 x SGPO
2 x SINGLE DATA
- **D01** Service Cupboard 01
2 x DGPO
1 x 32A 3PH
4 x SINGLE DATA
1 x 6C SMOF
WATER / WASTE
(BY HYDRAULIC CONTRACTOR)
- **D02** Service Cupboard 02
2 x DGPO
1 x 32A 3PH
4 x SINGLE DATA
1 x 6C SMOF
- **D06** Service Cupboard 06
1 x DGPO
1 x 20A SGPO
2 x SINGLE DATA
- **C01** Ceiling Box Type C01
1 x DGPO
1 x 30A 3PH
2 x SINGLE DATA
- **C02** Ceiling Box Type C02
1 x DGPO
1 x 20A SGPO
2 x SINGLE DATA
- ⊗ Rigging Point 1.0T
- Rigging Bar 100kg/lm
- Projector
- Circulation Front of house
- Circulation Back of house
- Public Space Build Zone



Level 3 Exhibition Centre

LEGEND

- **A01** Floor Box Type A01
6 x SGPO
2 x SINGLE DATA
- **A04** Floor Box Type A04
3 x SGPO
2 x SINGLE DATA
- **D01** Service Cupboard 01
2 x DGPO
1 x 32A 3PH
4 x SINGLE DATA
1 x 6C SMOF
WATER / WASTE
(BY HYDRAULIC CONTRACTOR)
- **D02** Service Cupboard 02
2 x DGPO
1 x 32A 3PH
4 x SINGLE DATA
1 x 6C SMOF
- **D06** Service Cupboard 06
1 x DGPO
1 x 20A SGPO
2 x SINGLE DATA
- **C01** Ceiling Box Type C02
1 x DGPO
1 x 30A 3PH
2 x SINGLE DATA
- **C02** Ceiling Box Type C02
1 x DGPO
1 x 20A SGPO
2 x SINGLE DATA
- ⊗ Rigging Point 1.0T
- Rigging Bar 100kg/lm
- Projector
- Circulation Front of house
- Circulation Back of house
- Public Space Build Zone

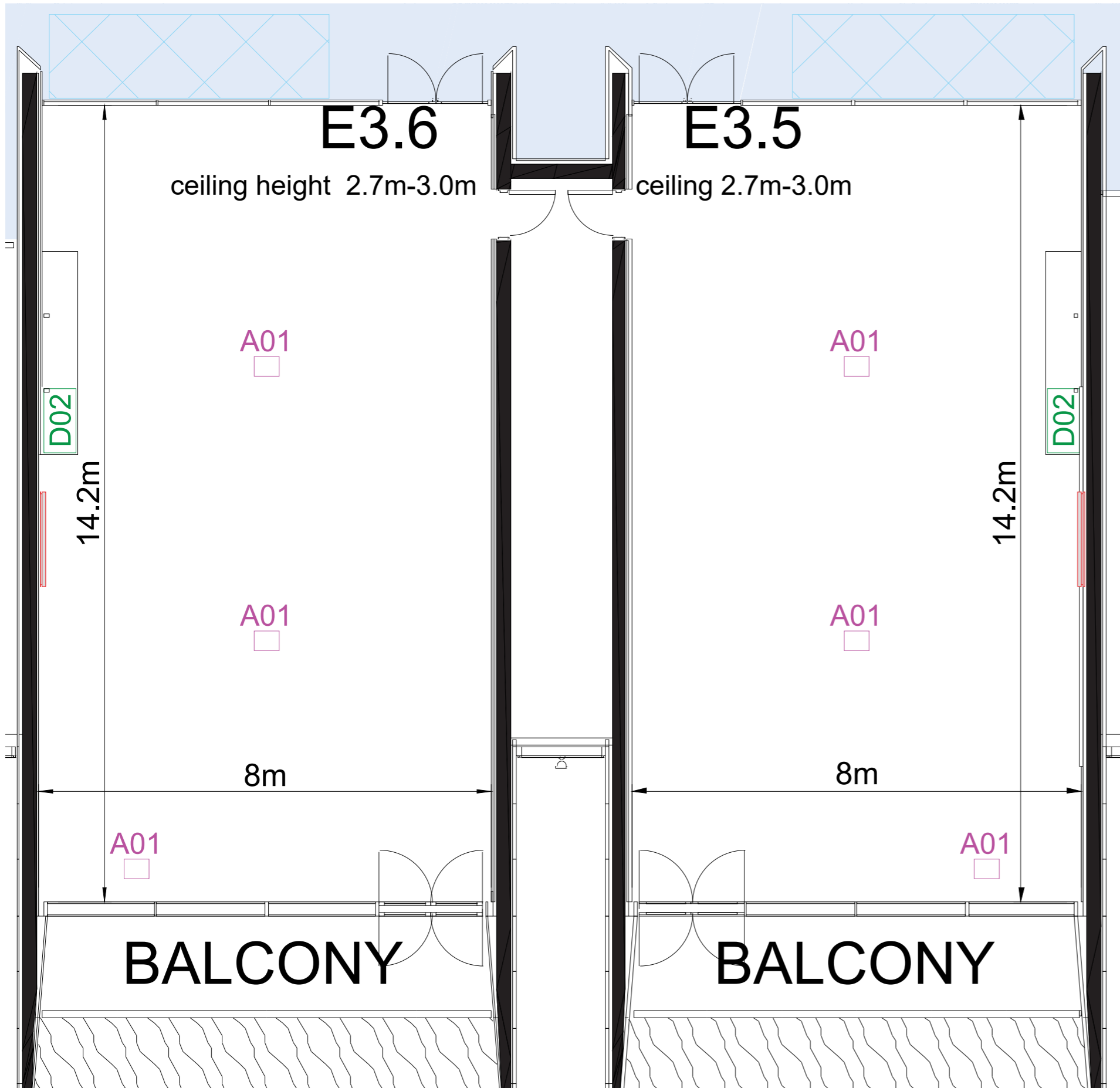

Level 3 Exhibition Centre

LEGEND

- A01** Floor Box Type A01
6 x SGPO
2 x SINGLE DATA
- A04** Floor Box Type A04
3 x SGPO
2 x SINGLE DATA
- D01** Service Cupboard 01
2 x DGPO
1 x 32A 3PH
4 x SINGLE DATA
1 x 6C SMOF
WATER / WASTE
(BY HYDRAULIC CONTRACTOR)
- D02** Service Cupboard 02
2 x DGPO
1 x 32A 3PH
4 x SINGLE DATA
1 x 6C SMOF
- D06** Service Cupboard 06
1 x DGPO
1 x 20A SGPO
2 x SINGLE DATA
- C01** Ceiling Box Type C02
1 x DGPO
1 x 30A 3PH
2 x SINGLE DATA
- C02** Ceiling Box Type C02
1 x DGPO
1 x 20A SGPO
2 x SINGLE DATA
- Rigging Point 1.0T
- Rigging Bar 100kg/lm
- Projector
- Circulation Front of house
- Circulation Back of house
- Public Space Build Zone

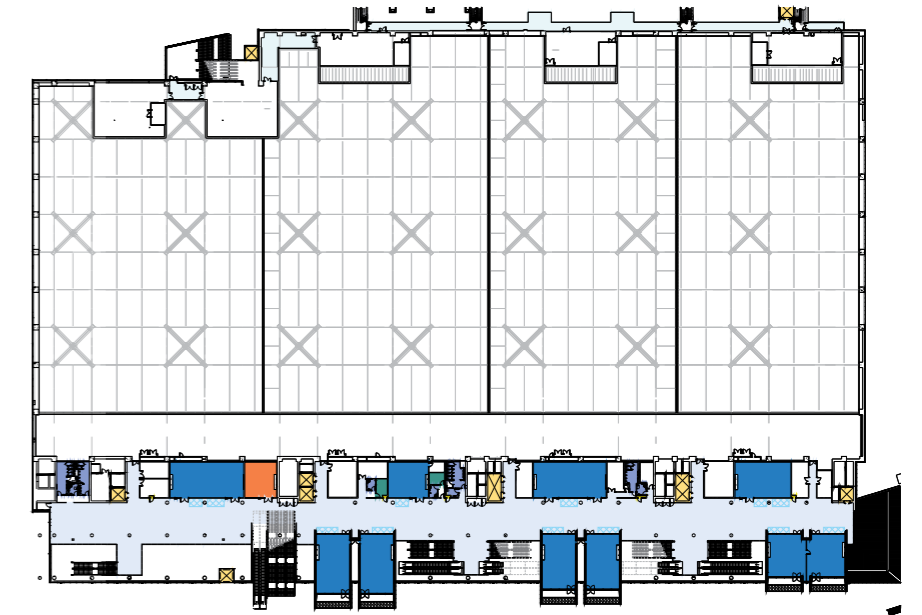
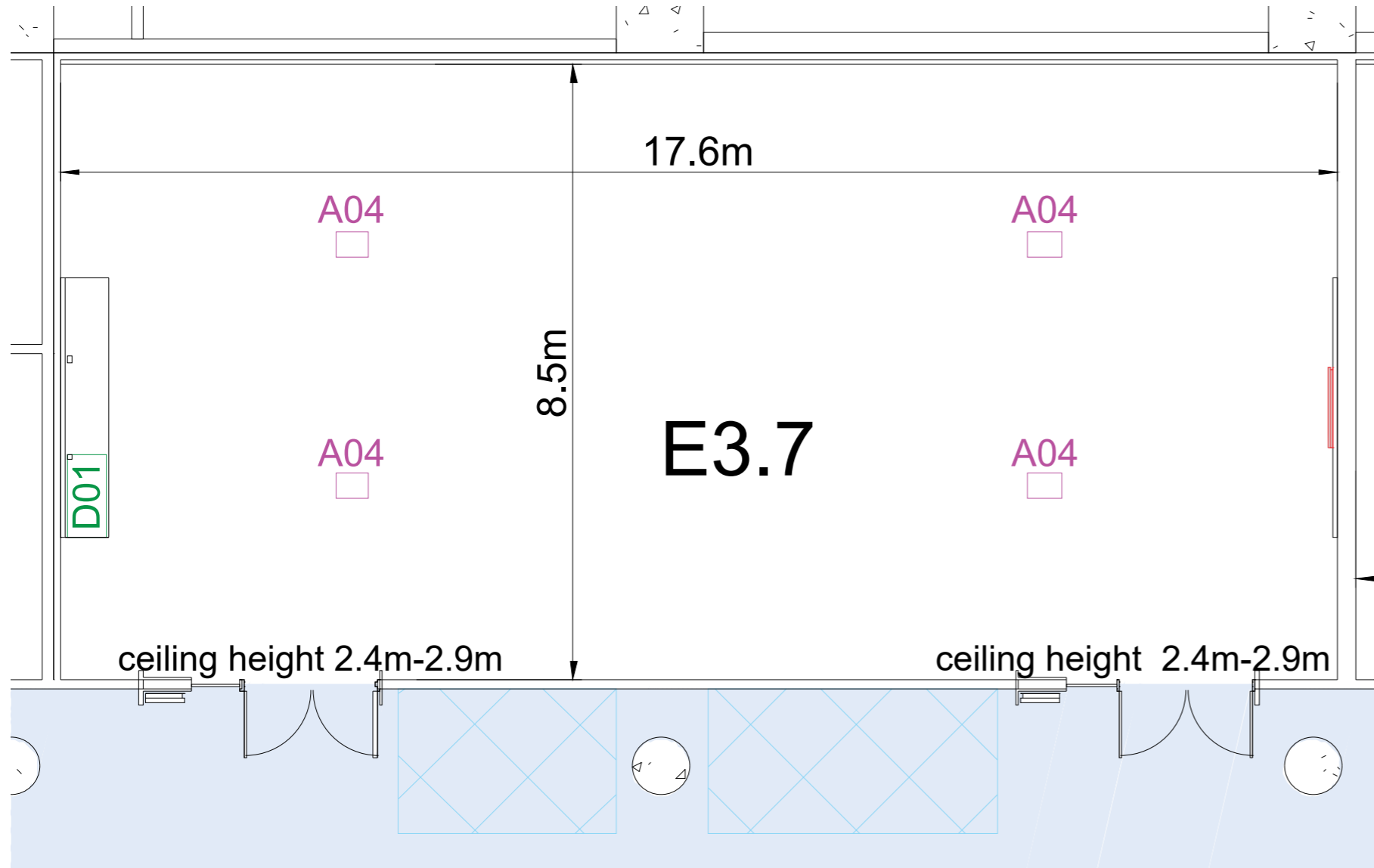

Level 3 Exhibition Centre

LEGEND

- **A01** Floor Box Type A01
6 x SGPO
2 x SINGLE DATA
- **A04** Floor Box Type A04
3 x SGPO
2 x SINGLE DATA
- **D01** Service Cupboard 01
2 x DGPO
1 x 32A 3PH
4 x SINGLE DATA
1 x 6C SMOF
WATER / WASTE
(BY HYDRAULIC CONTRACTOR)
- **D02** Service Cupboard 02
2 x DGPO
1 x 32A 3PH
4 x SINGLE DATA
1 x 6C SMOF
- **D06** Service Cupboard 06
1 x DGPO
1 x 20A SGPO
2 x SINGLE DATA
- **C01** Ceiling Box Type C02
1 x DGPO
1 x 30A 3PH
2 x SINGLE DATA
- **C02** Ceiling Box Type C02
1 x DGPO
1 x 20A SGPO
2 x SINGLE DATA
- ⊗ Rigging Point 1.0T
- Rigging Bar 100kg/lm
- Projector
- Circulation Front of house
- Circulation Back of house
- Public Space Build Zone

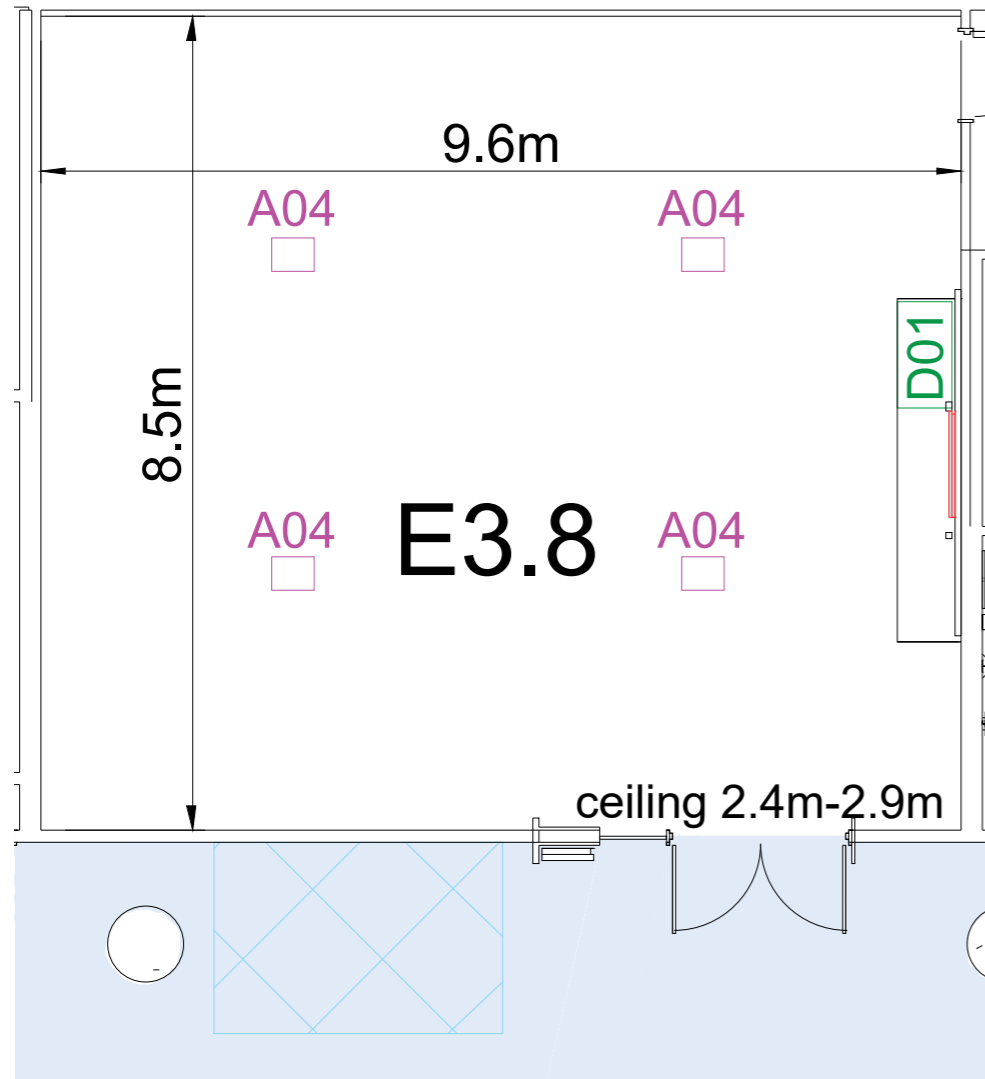

Level 3 Exhibition Centre

LEGEND

- **A01** Floor Box Type A01
6 x SGPO
2 x SINGLE DATA
- **A04** Floor Box Type A04
3 x SGPO
2 x SINGLE DATA
- **D01** Service Cupboard 01
2 x DGPO
1 x 32A 3PH
4 x SINGLE DATA
1 x 6C SMOF
WATER / WASTE
(BY HYDRAULIC CONTRACTOR)
- **D02** Service Cupboard 02
2 x DGPO
1 x 32A 3PH
4 x SINGLE DATA
1 x 6C SMOF
- **D06** Service Cupboard 06
1 x DGPO
1 x 20A SGPO
2 x SINGLE DATA
- **C01** Ceiling Box Type C02
1 x DGPO
1 x 30A 3PH
2 x SINGLE DATA
- **C02** Ceiling Box Type C02
1 x DGPO
1 x 20A SGPO
2 x SINGLE DATA
- ⊗ Rigging Point 1.0T
- Rigging Bar 100kg/lm
- Projector
- Circulation Front of house
- Circulation Back of house
- Public Space Build Zone



Level 3 Exhibition Centre

LEGEND

- **A01** Floor Box Type A01
6 x SGPO
2 x SINGLE DATA
- **A04** Floor Box Type A04
3 x SGPO
2 x SINGLE DATA
- **D01** Service Cupboard 01
2 x DGPO
1 x 32A 3PH
4 x SINGLE DATA
1 x 6C SMOF
WATER / WASTE
(BY HYDRAULIC CONTRACTOR)
- **D02** Service Cupboard 02
2 x DGPO
1 x 32A 3PH
4 x SINGLE DATA
1 x 6C SMOF
- **D06** Service Cupboard 06
1 x DGPO
1 x 20A SGPO
2 x SINGLE DATA
- **C01** Ceiling Box Type C02
1 x DGPO
1 x 30A 3PH
2 x SINGLE DATA
- **C02** Ceiling Box Type C02
1 x DGPO
1 x 20A SGPO
2 x SINGLE DATA
- ⊗ Rigging Point 1.0T
- Rigging Bar 100kg/lm
- Projector
- Circulation Front of house
- Circulation Back of house
- Public Space Build Zone

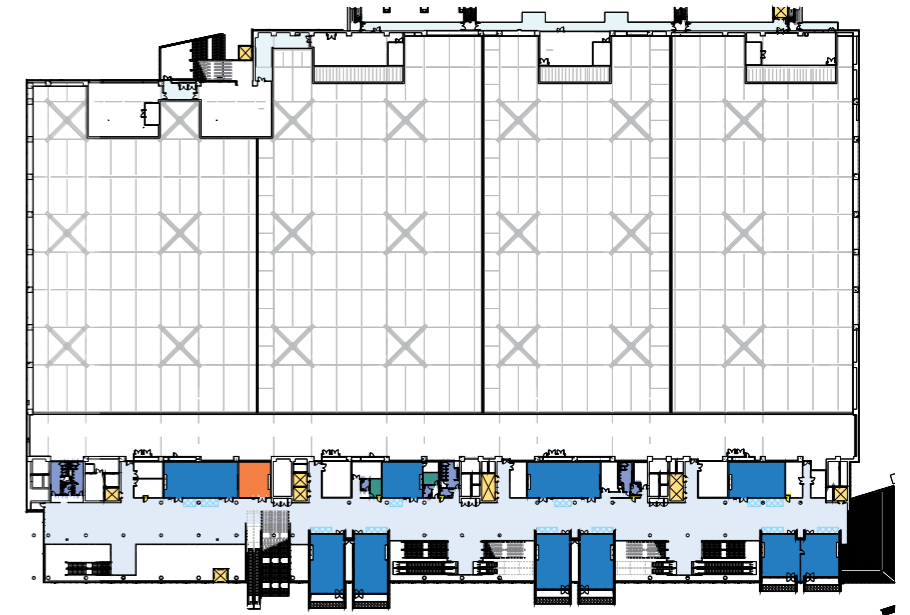
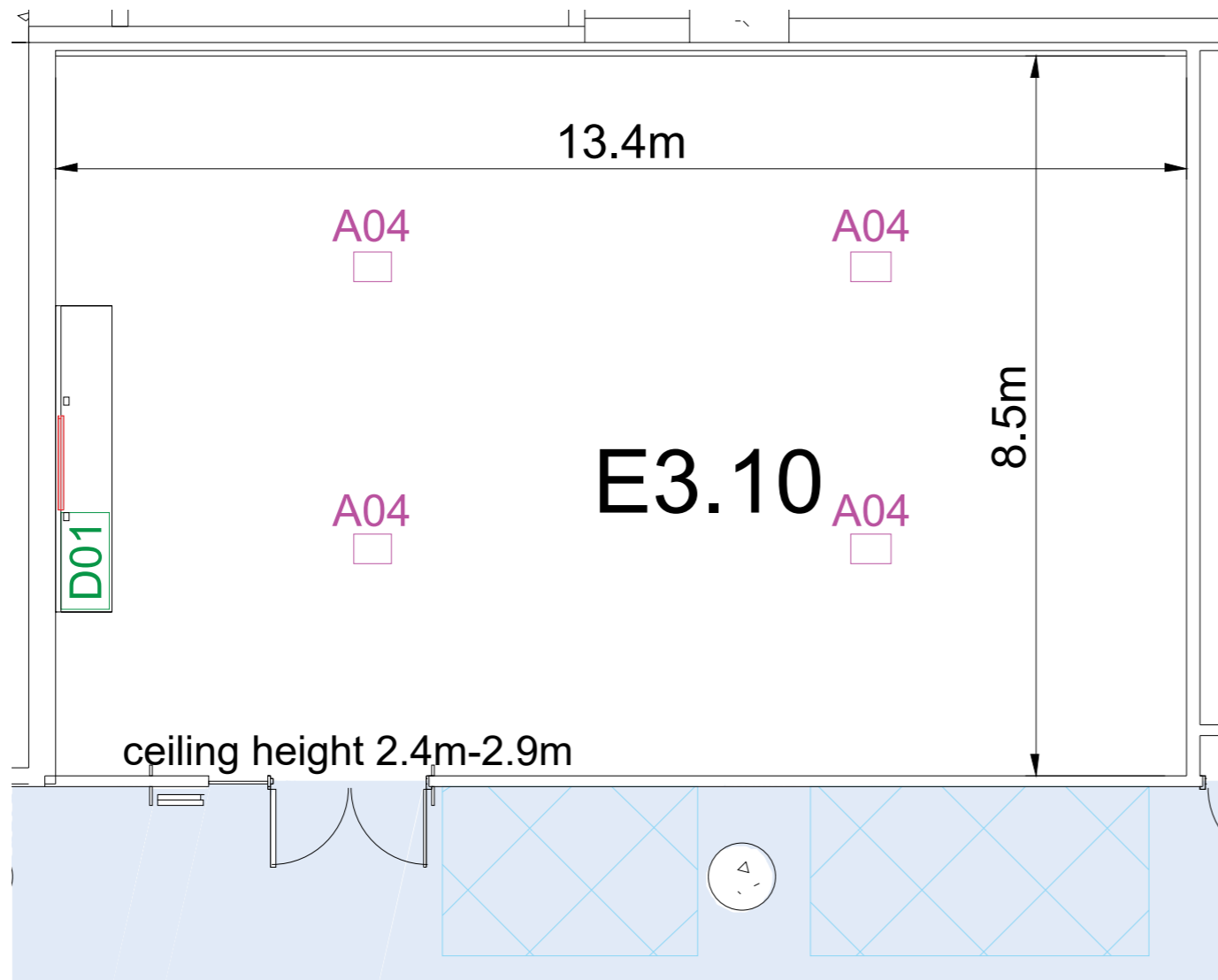

Level 3 Exhibition Centre

LEGEND

- **A01** Floor Box Type A01
6 x SGPO
2 x SINGLE DATA
- **A04** Floor Box Type A04
3 x SGPO
2 x SINGLE DATA
- **D01** Service Cupboard 01
2 x DGPO
1 x 32A 3PH
4 x SINGLE DATA
1 x 6C SMOF
WATER / WASTE
(BY HYDRAULIC CONTRACTOR)
- **D02** Service Cupboard 02
2 x DGPO
1 x 32A 3PH
4 x SINGLE DATA
1 x 6C SMOF
- **D06** Service Cupboard 06
1 x DGPO
1 x 20A SGPO
2 x SINGLE DATA
- **C01** Ceiling Box Type C02
1 x DGPO
1 x 30A 3PH
2 x SINGLE DATA
- **C02** Ceiling Box Type C02
1 x DGPO
1 x 20A SGPO
2 x SINGLE DATA
- ⊗ Rigging Point 1.0T
- Rigging Bar 100kg/lm
- Projector
- Circulation Front of house
- Circulation Back of house
- Public Space Build Zone



Level 3 Exhibition Centre

LEGEND

- **A01** Floor Box Type A01
6 x SGPO
2 x SINGLE DATA
- **A04** Floor Box Type A04
3 x SGPO
2 x SINGLE DATA
- **D01** Service Cupboard 01
2 x DGPO
1 x 32A 3PH
4 x SINGLE DATA
1 x 6C SMOF
WATER / WASTE
(BY HYDRAULIC CONTRACTOR)
- **D02** Service Cupboard 02
2 x DGPO
1 x 32A 3PH
4 x SINGLE DATA
1 x 6C SMOF
- **D06** Service Cupboard 06
1 x DGPO
1 x 20A SGPO
2 x SINGLE DATA
- **C01** Ceiling Box Type C02
1 x DGPO
1 x 30A 3PH
2 x SINGLE DATA
- **C02** Ceiling Box Type C02
1 x DGPO
1 x 20A SGPO
2 x SINGLE DATA
- ⊗ Rigging Point 1.0T
- Rigging Bar 100kg/lm
- Projector
- Circulation Front of house
- Circulation Back of house
- Public Space Build Zone

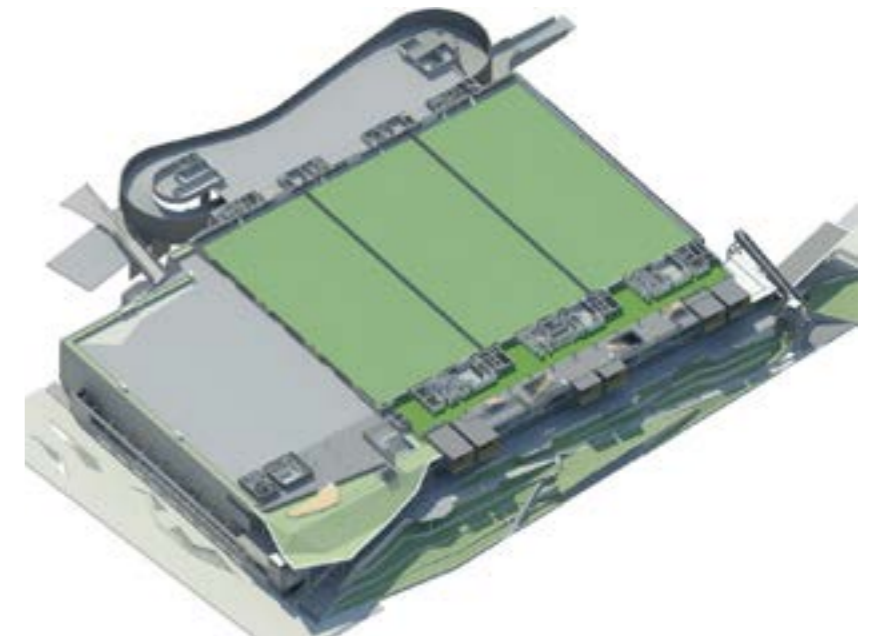

Axonometric cutaway view of Level 4 Exhibition Centre

LEGEND

- Circulation
- Lifts
- Fire Hydrants
- Toilets / Facilities
- Accessible Toilet
- Exhibition Halls
- Loading Dock
- Event Deck
- Kiosk
- Event Deck / Servery

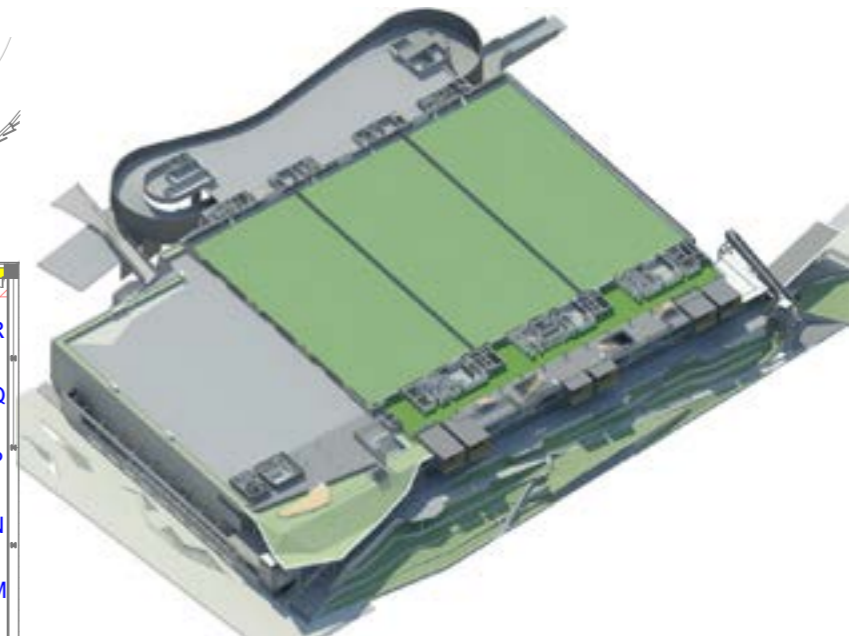

Axonometric cutaway view of Level 4 Exhibition Centre

753 3m x 3m booths shown

LEGEND

- Circulation
- Lifts
- Fire Hydrants
- Toilets / Facilities
- Accessible Toilet
- Exhibition Halls
- Loading Dock
- Event Deck
- Kiosk
- Event Deck / Servery
- No Build Zone
- No Build Catering
- No Build Zone
Emergency Exit
- Water and drainage connection
pit
- Trench
- Trench + Compressed Air
- Power Lock (each power lock,
east and west, shares 400A
between lower and upper halls)
- Service Pit Type 1
1 x SGPO
1 x 32A 3PH
1 x SINGLE DATA
1 x 2C SMOF
- Service Pit Type 2
1 x SGPO
1 x 32A 3PH

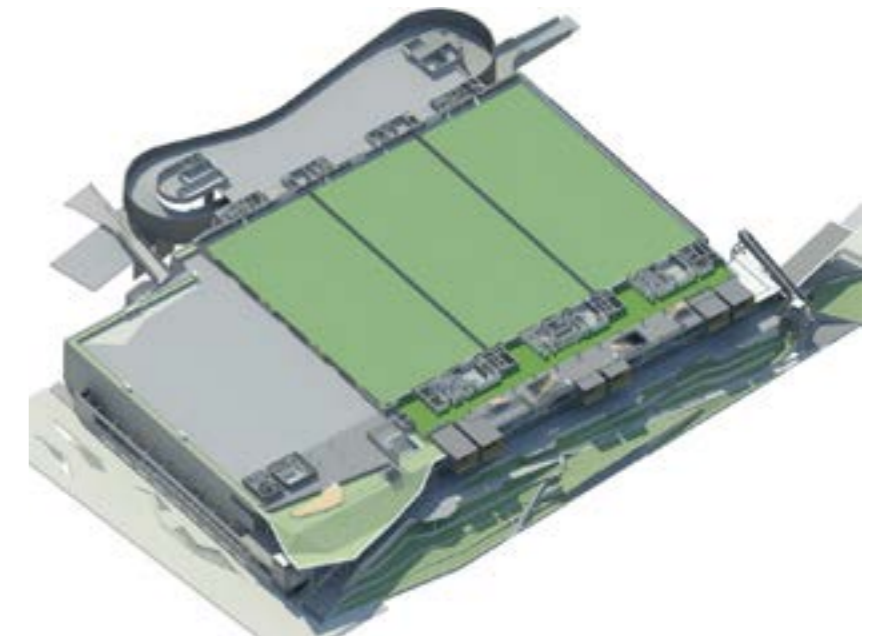
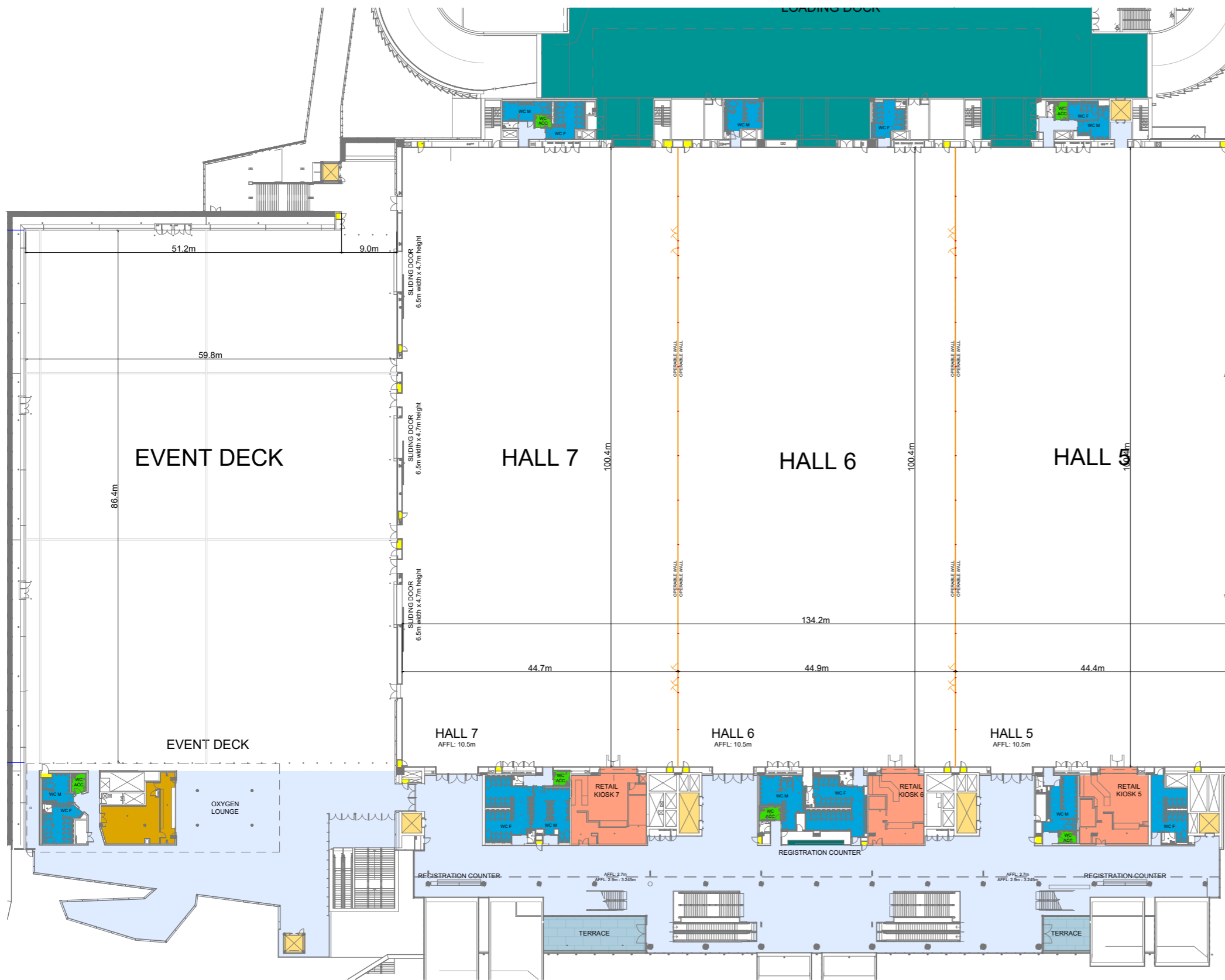

Axonometric cutaway view of Level 4 Exhibition Centre

LEGEND

- Circulation
- Lifts
- Fire Hydrants
- Toilets / Facilities
- Accessible Toilet
- Exhibition Halls
- Loading Dock
- Event Deck
- Kiosk
- Event Deck / Servery

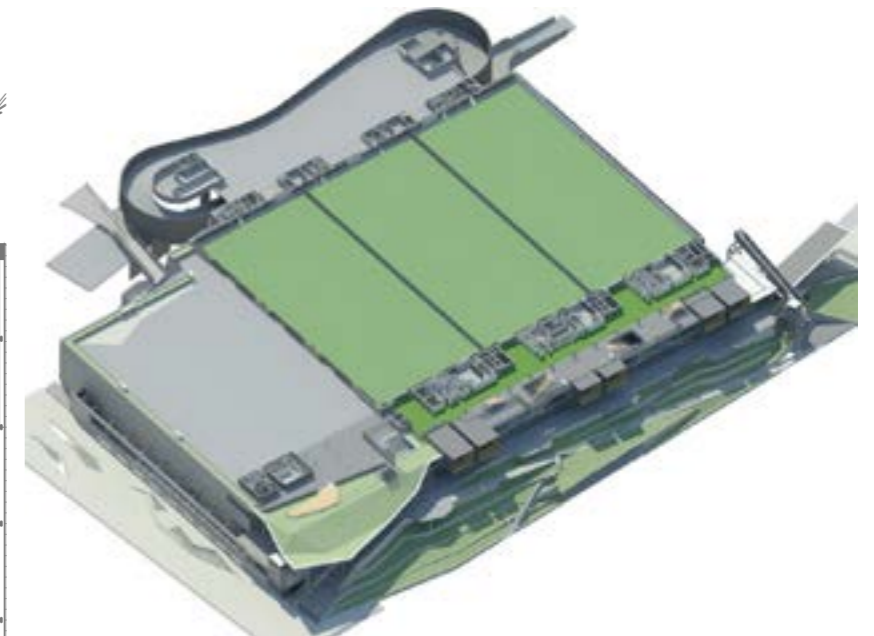
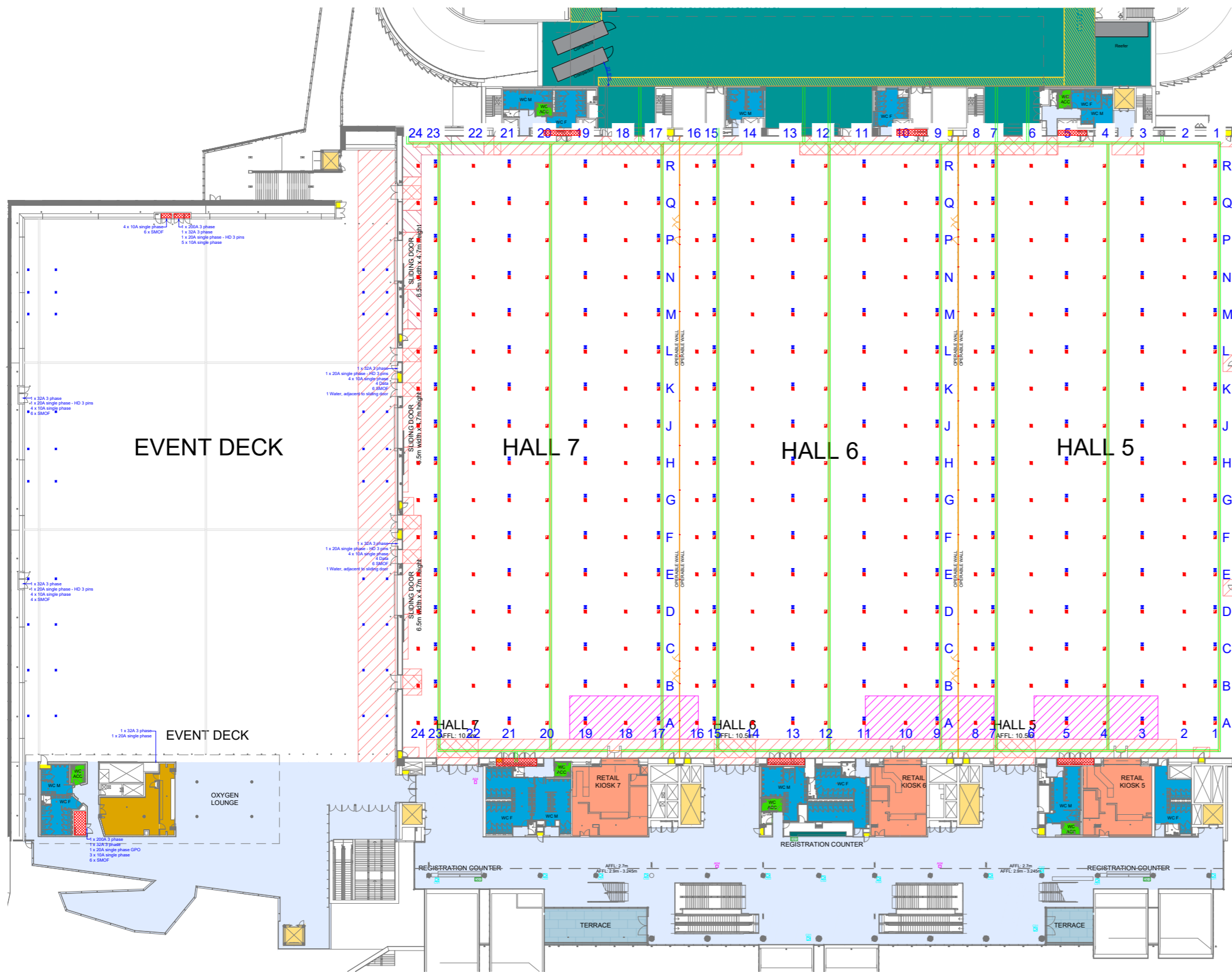

Axonometric cutaway view of Level 4 Exhibition Centre

LEGEND

- Circulation
- Lifts
- Fire Hydrants
- Toilets / Facilities
- Accessible Toilet
- Exhibition Halls
- Loading Dock
- Event Deck
- Kiosk
- Event Deck / Servery
- No Build Zone
- No Build Catering
- No Build Zone
Emergency Exit
- Water and drainage connection
pit
- Trench
- Trench + Compressed Air
- Power Lock (each power lock,
east and west, shares 400A
between lower and upper halls)
- Service Pit Type 1
1 x SGPO
1 x 32A 3PH
1 x SINGLE DATA
1 x 2C SMOF
- Service Pit Type 2
1 x SGPO
1 x 32A 3PH

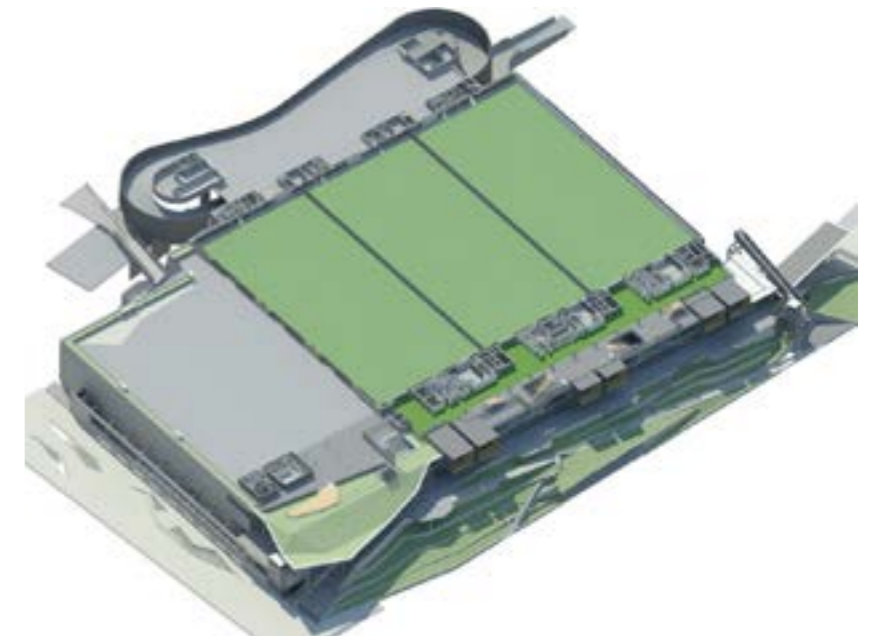
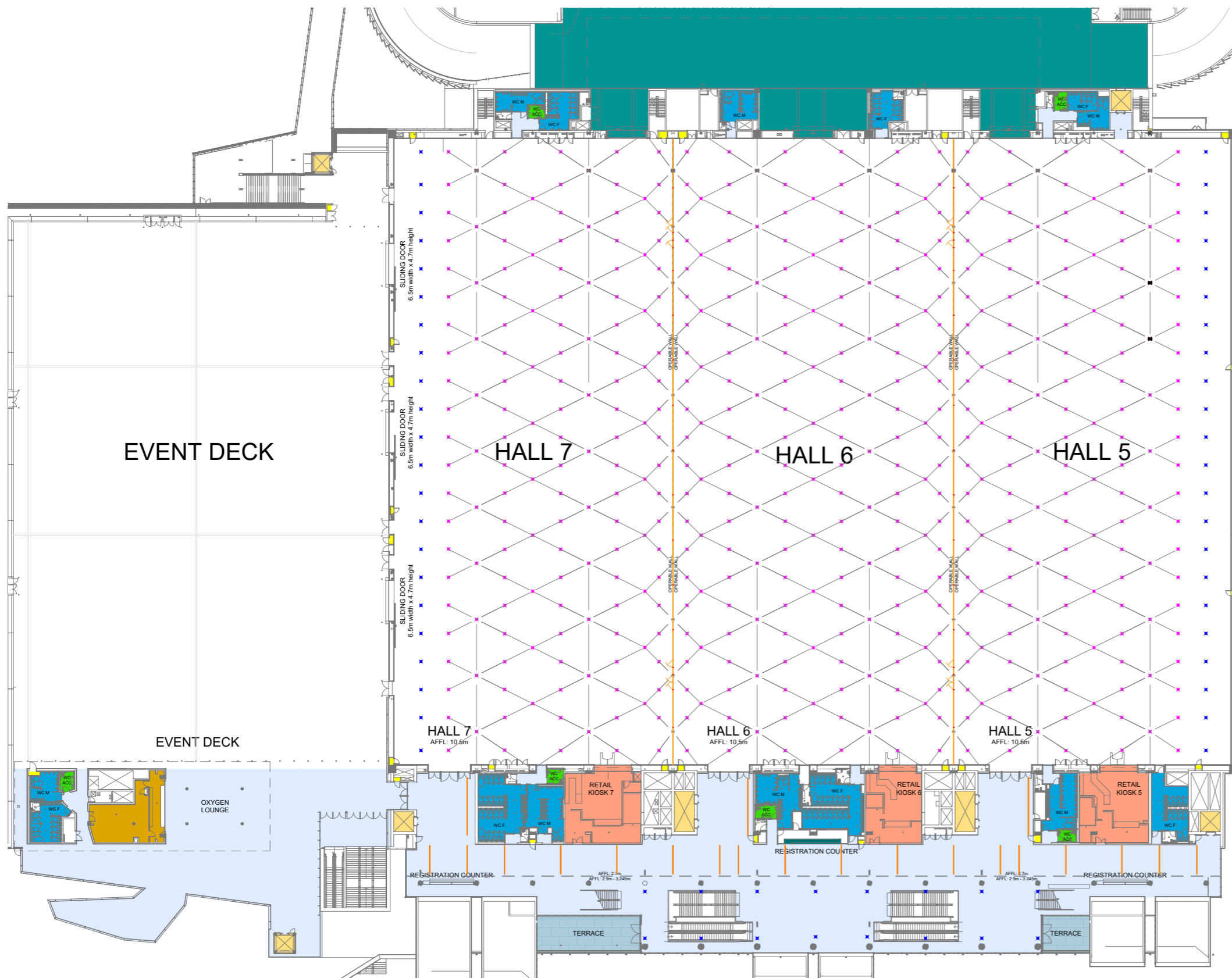

Axonometric cutaway view of Level 4 Exhibition Centre

LEGEND

- Circulation
- Lifts
- Fire Hydrants
- Toilets / Facilities
- Accessible Toilet
- Exhibition Halls
- Loading Dock
- Event Deck
- Kiosk
- Event Deck / Servery
- Rigging Point 2.5T
- Rigging Point 1.0T
- Rigging Bar 100kg/lm

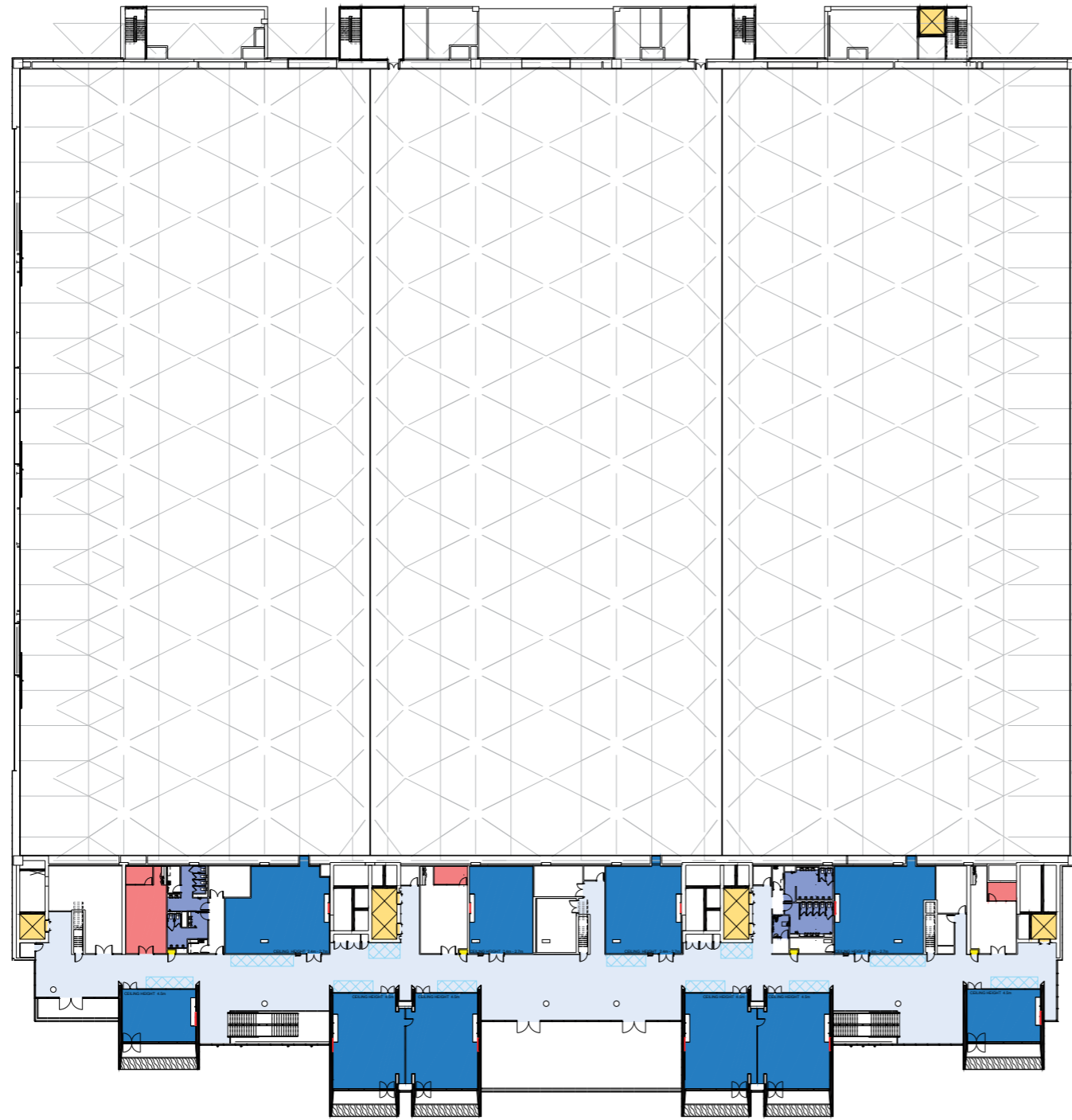

Axonometric cutaway view of Level 5 Exhibition Centre

LEGEND

-  Circulation Front of house
-  Circulation Back of house
-  Lifts
-  Fire hydrant
-  Toilets / facilities
-  Organiser's offices and Suites
-  Public Space Build Zone

LEGEND

- Circulation Front of house
- Circulation Back of house
- Lifts
- Fire hydrant
- Toilets / facilities
- Organiser's offices and Suites
- Public Space Build Zone
- Rigging Bar 100kg/lm

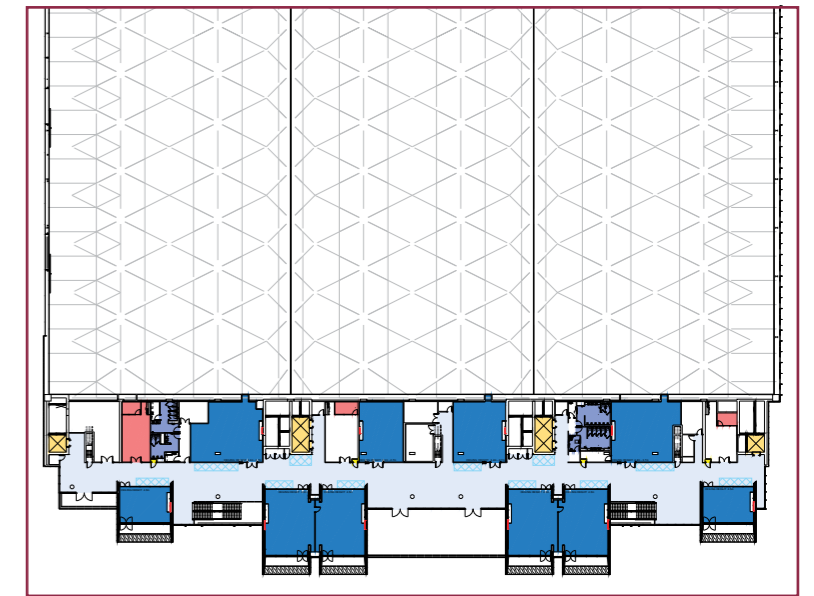

Level 5 Exhibition Centre

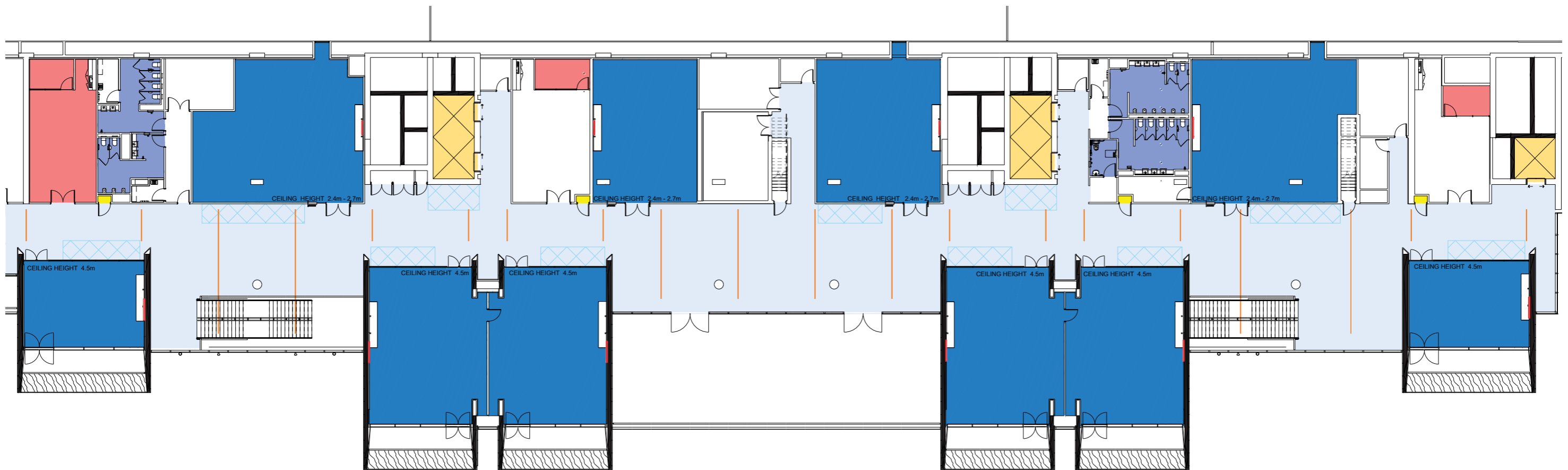

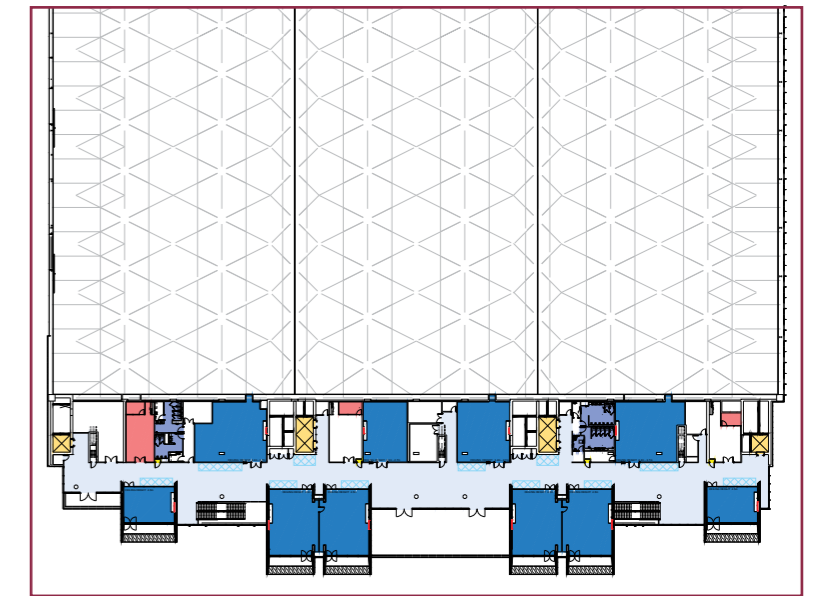
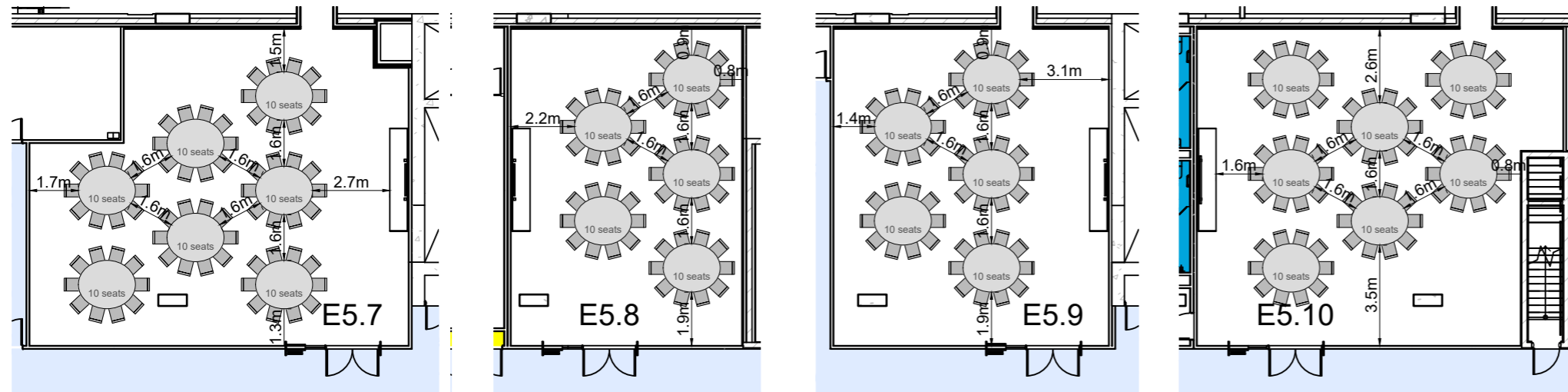

Level 5 Exhibition Centre

LEGEND

- Circulation Front of house
- Circulation Back of house
- Lifts
- Fire hydrant
- Toilets / facilities
- Organiser's offices and Suites
- Public Space Build Zone

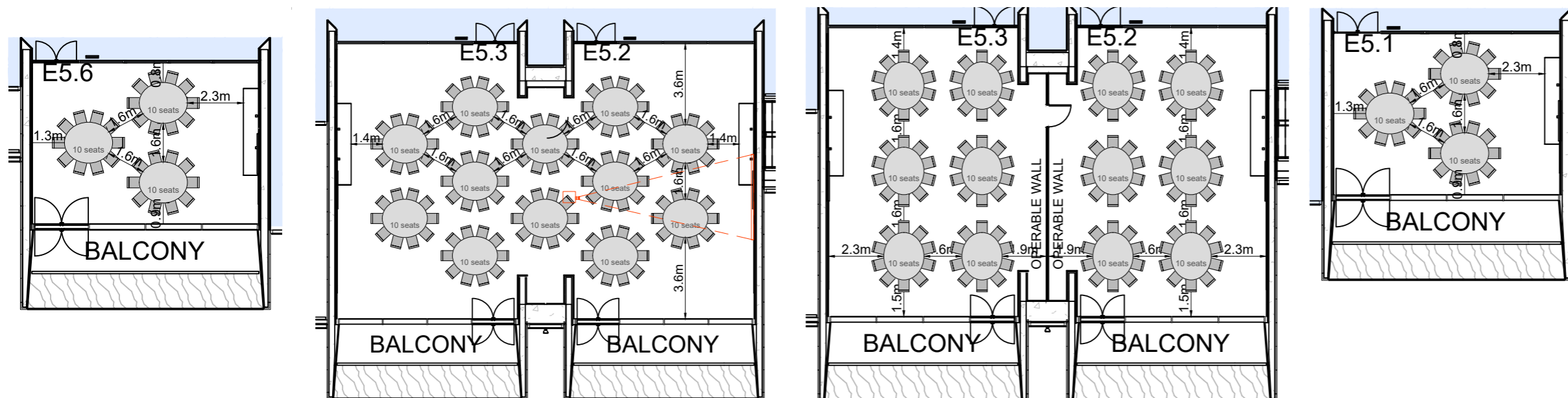

ROOM NAME	BANQUET
MEETING ROOM E5.1	30
MEETING ROOM E5.2	60
MEETING ROOM E5.3	60
MEETING ROOM E5.2 & E5.3	120
MEETING ROOM E5.4	60
MEETING ROOM E5.5	60
MEETING ROOM E5.4 & E5.5	120
MEETING ROOM E5.6	30
MEETING ROOM E5.7	70
MEETING ROOM E5.8	50
MEETING ROOM E5.9	50
MEETING ROOM E5.10	70

* Standard capacity illustrated. Higher capacities can be achieved with less staging and AV services and reduced furniture spacing. Please consider your event requirements when viewing capacities.

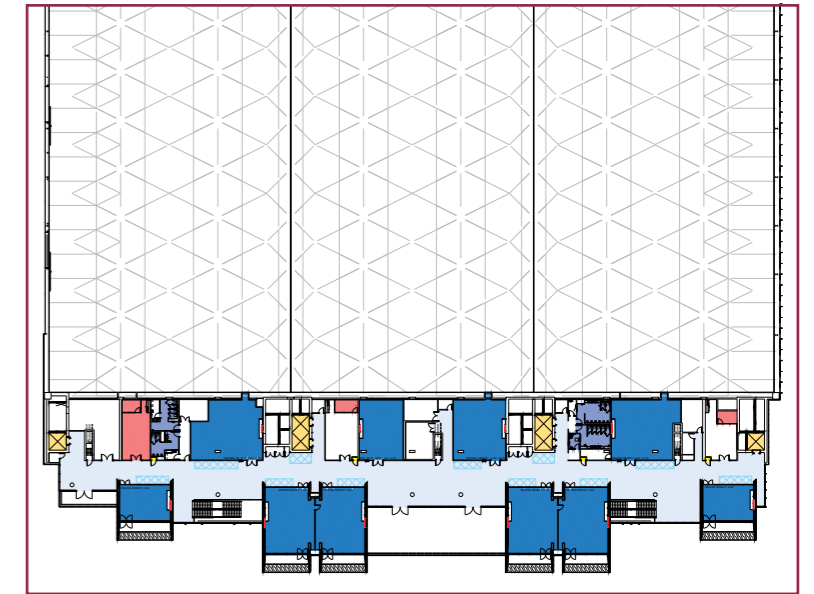
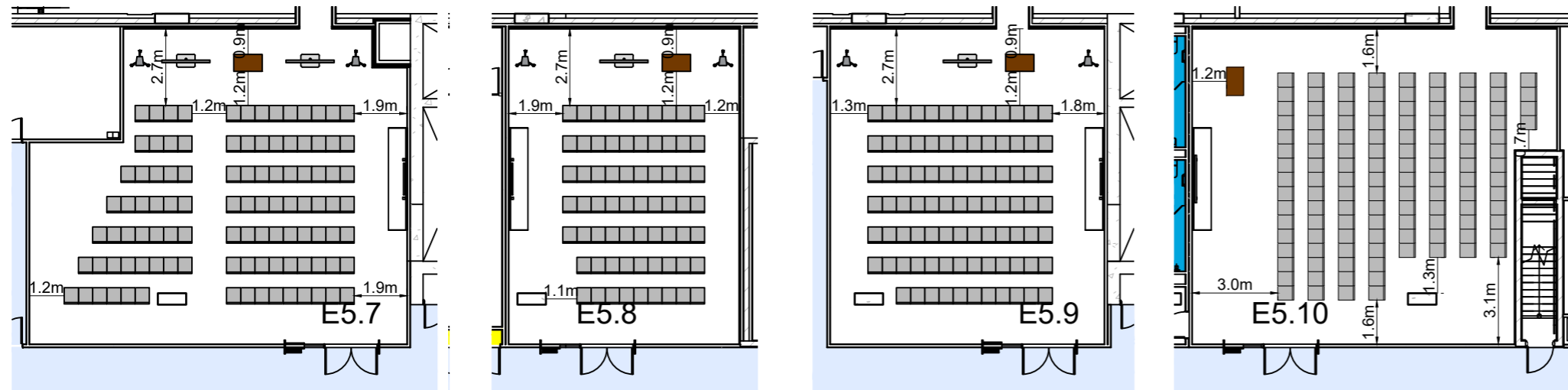

Level 5 Exhibition Centre

LEGEND

- Circulation Front of house
- Circulation Back of house
- Lifts
- Fire hydrant
- Toilets / facilities
- Organiser's offices and Suites
- Public Space Build Zone

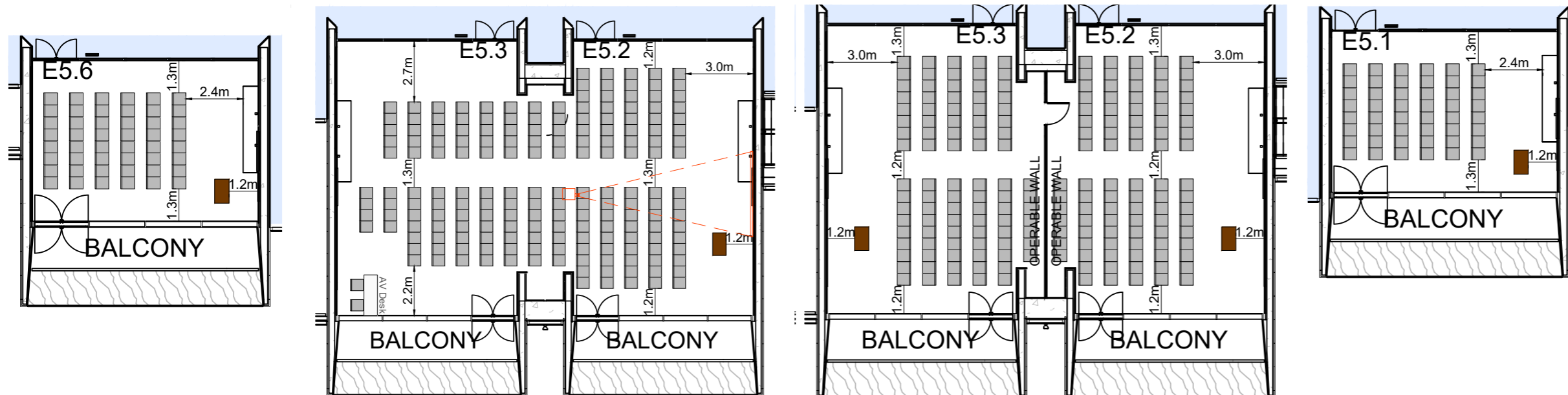

ROOM NAME	THEATRE
MEETING ROOM E5.1	48
MEETING ROOM E5.2	92
MEETING ROOM E5.3	92
MEETING ROOM E5.2 & E5.3	182
MEETING ROOM E5.4	92
MEETING ROOM E5.5	92
MEETING ROOM E5.4 & E5.5	182
MEETING ROOM E5.6	48
MEETING ROOM E5.7	103
MEETING ROOM E5.8	68
MEETING ROOM E5.9	89
MEETING ROOM E5.10	120

* Standard capacity illustrated. Higher capacities can be achieved with less staging and AV services and reduced furniture spacing. Please consider your event requirements when viewing capacities.

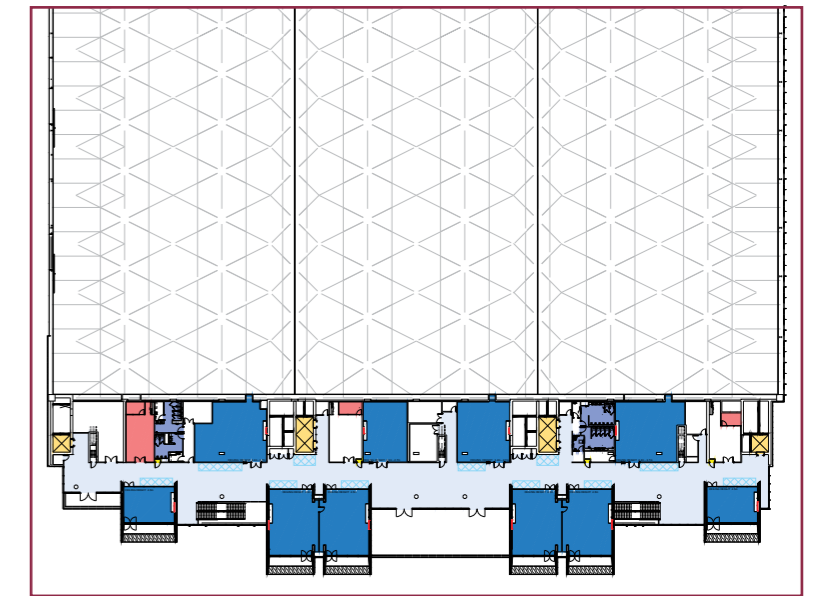
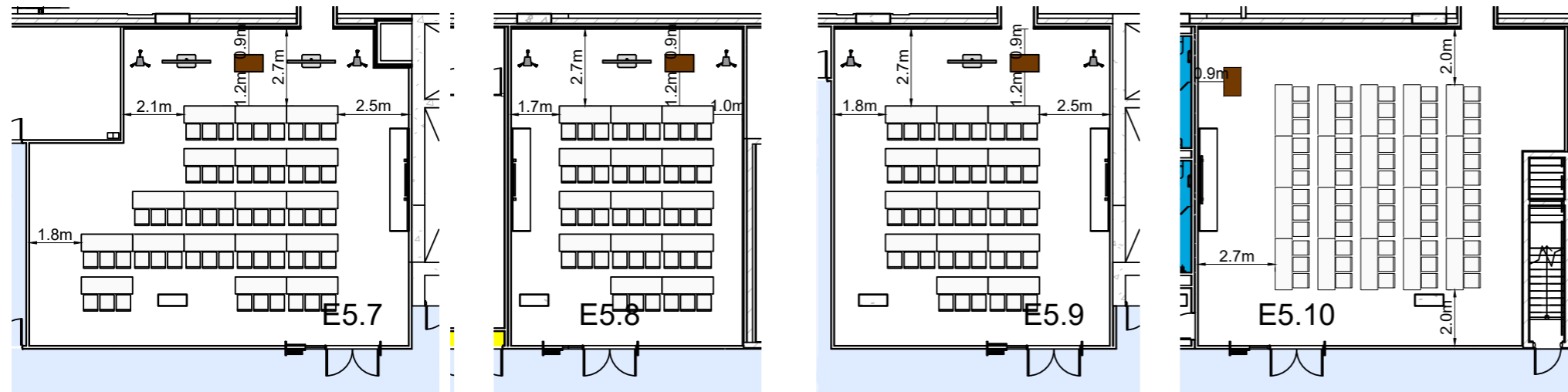

Level 5 Exhibition Centre

LEGEND

- Circulation Front of house
- Circulation Back of house
- Lifts
- Fire hydrant
- Toilets / facilities
- Organiser's offices and Suites
- Public Space Build Zone

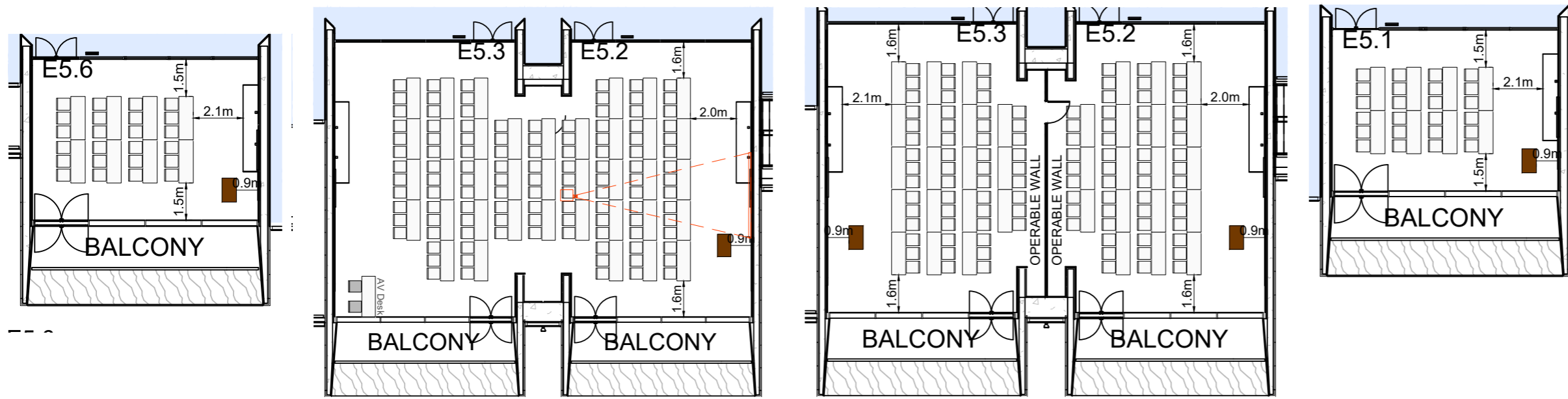

* Standard capacity illustrated. Higher capacities can be achieved with less staging and AV services and reduced furniture spacing. Please consider your event requirements when viewing capacities.

ROOM NAME	CLASSROOM
MEETING ROOM E5.1	24
MEETING ROOM E5.2	54
MEETING ROOM E5.3	54
MEETING ROOM E5.2 & E5.3	114
MEETING ROOM E5.4	54
MEETING ROOM E5.5	54
MEETING ROOM E5.4 & E5.5	114
MEETING ROOM E5.6	24
MEETING ROOM E5.7	54
MEETING ROOM E5.8	42
MEETING ROOM E5.9	42
MEETING ROOM E5.10	60

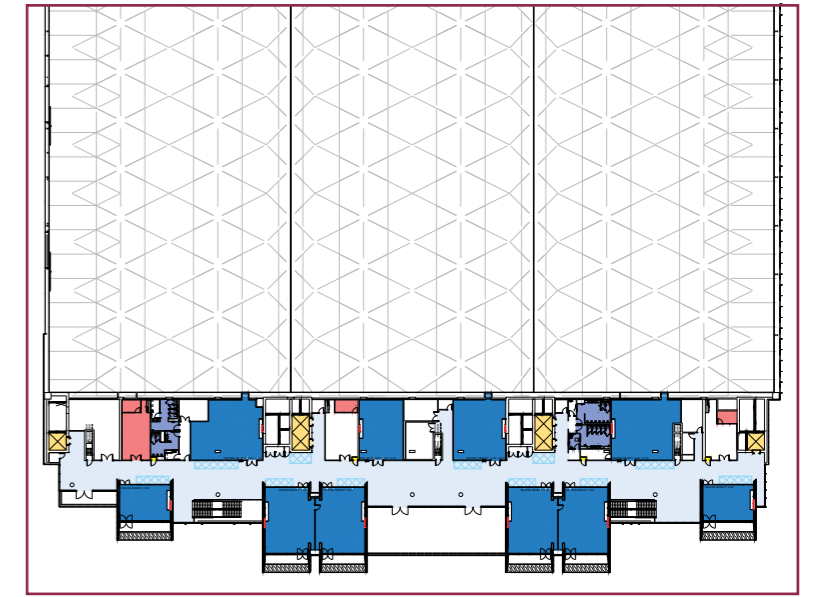
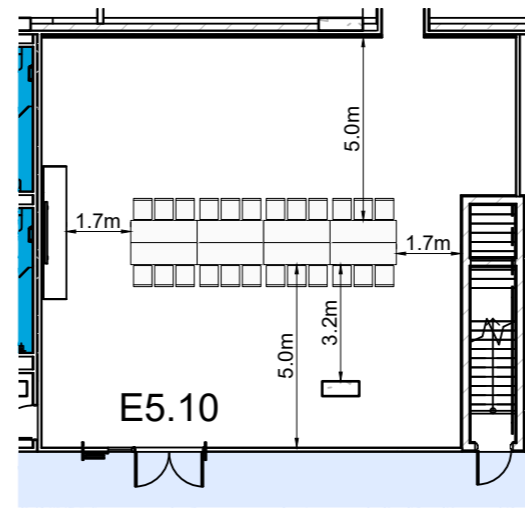
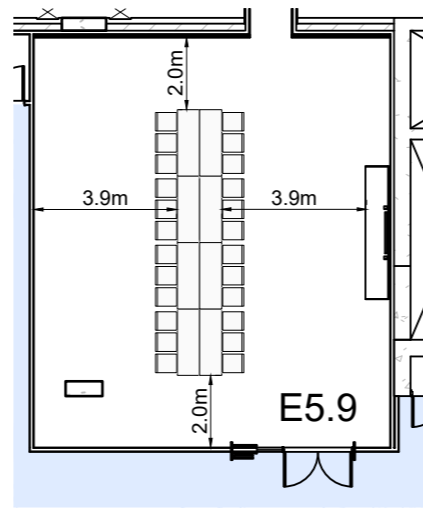
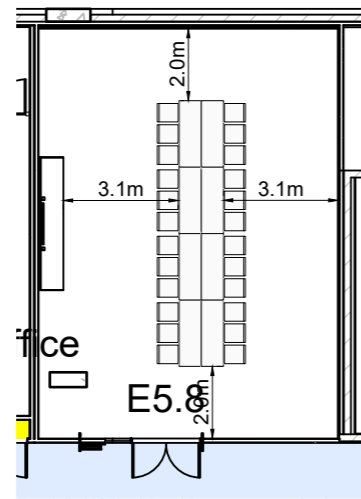
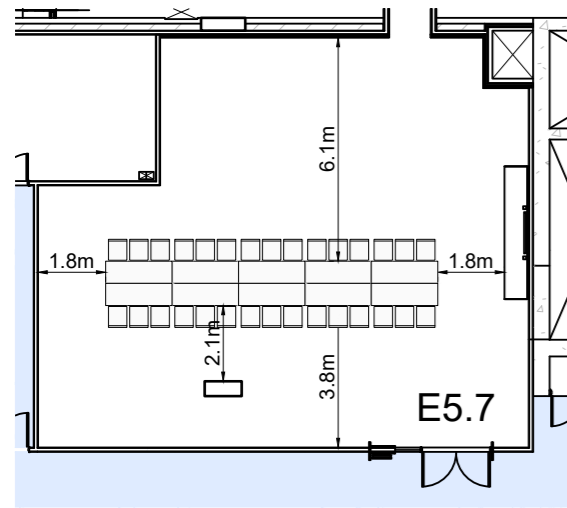

Level 5 Exhibition Centre

LEGEND

- Circulation Front of house
- Circulation Back of house
- Lifts
- Fire hydrant
- Toilets / facilities
- Organiser's offices and Suites
- Public Space Build Zone

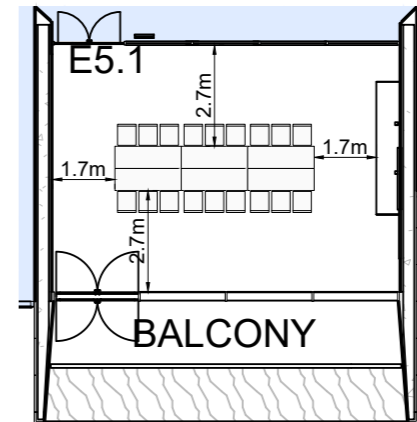
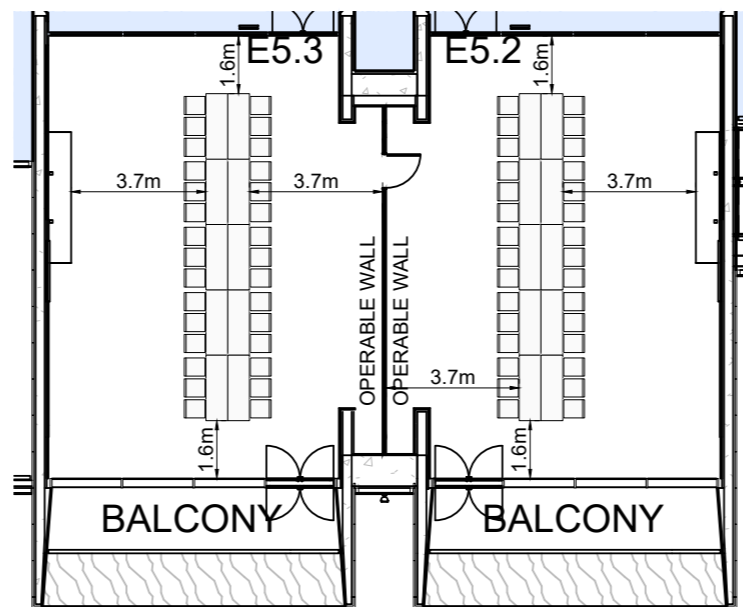
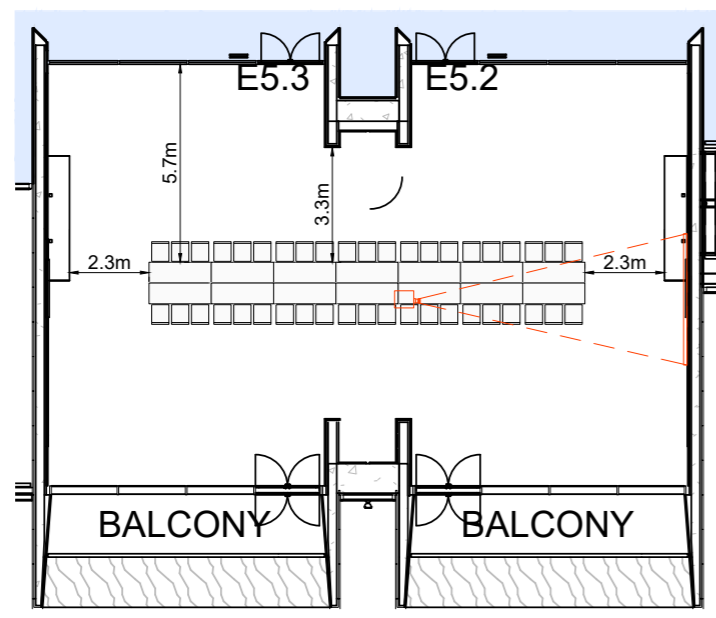
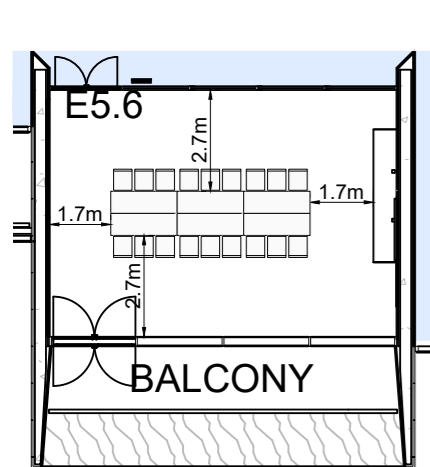

*Maximum Capacity illustrated.

ROOM NAME	BOARDROOM
MEETING ROOM E5.1	18
MEETING ROOM E5.2	30
MEETING ROOM E5.3	30
MEETING ROOM E5.2 & E5.3	42
MEETING ROOM E5.4	30
MEETING ROOM E5.5	30
MEETING ROOM E5.4 & E5.5	42
MEETING ROOM E5.6	18
MEETING ROOM E5.7	30
MEETING ROOM E5.8	24
MEETING ROOM E5.9	24
MEETING ROOM E5.10	24

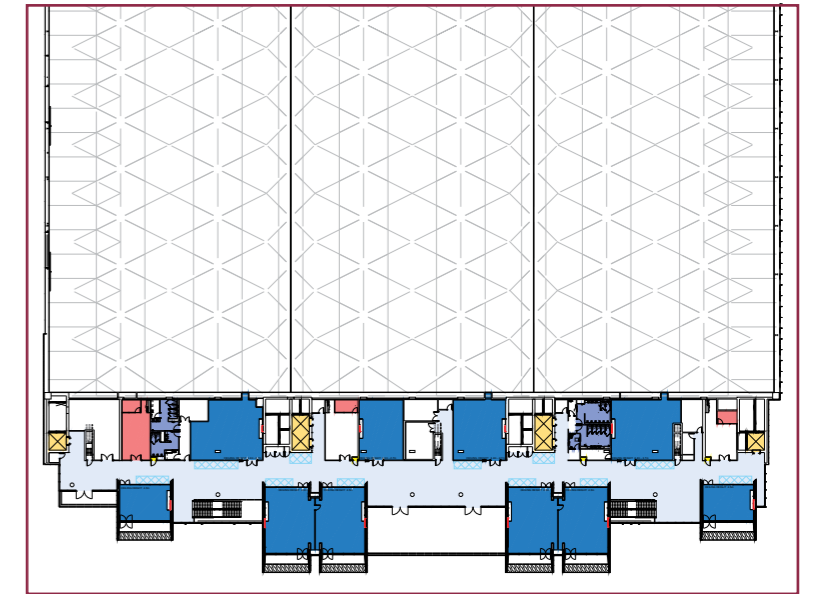
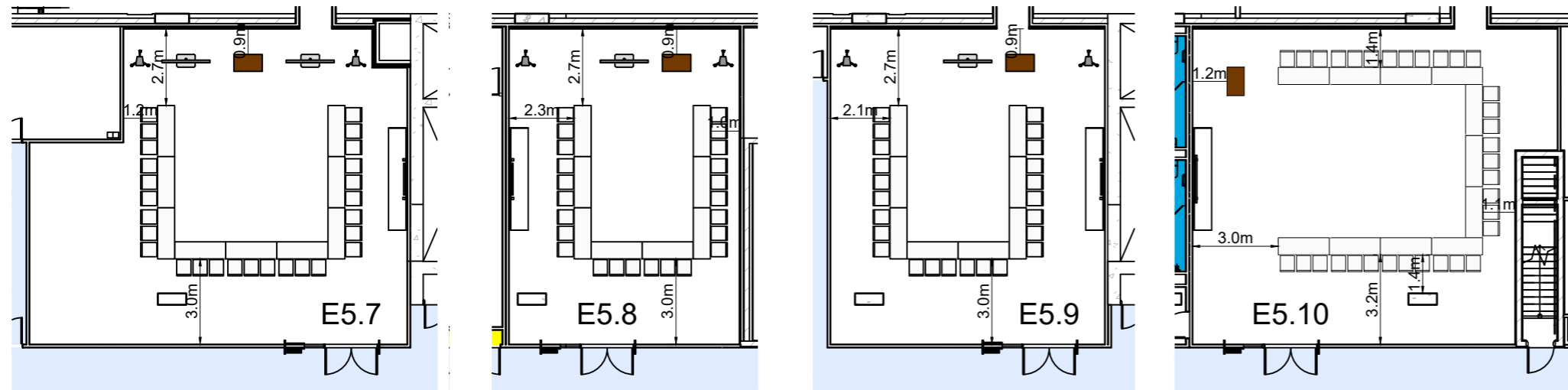

Level 5 Exhibition Centre

LEGEND

- Circulation Front of house
- Circulation Back of house
- Lifts
- Fire hydrant
- Toilets / facilities
- Organiser's offices and Suites
- Public Space Build Zone

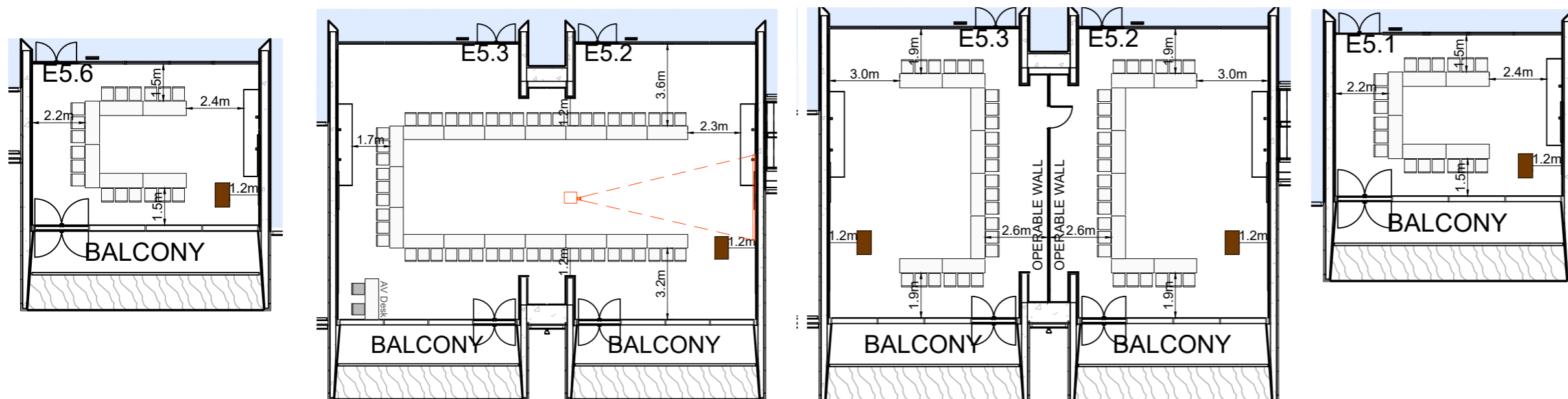

ROOM NAME	U SHAPE
MEETING ROOM E5.1	18
MEETING ROOM E5.2	24
MEETING ROOM E5.3	24
MEETING ROOM E5.2 & E5.3	51
MEETING ROOM E5.4	24
MEETING ROOM E5.5	24
MEETING ROOM E5.4 & E5.5	51
MEETING ROOM E5.6	18
MEETING ROOM E5.7	27
MEETING ROOM E5.8	24
MEETING ROOM E5.9	24
MEETING ROOM E5.10	33

*Maximum Capacity illustrated.

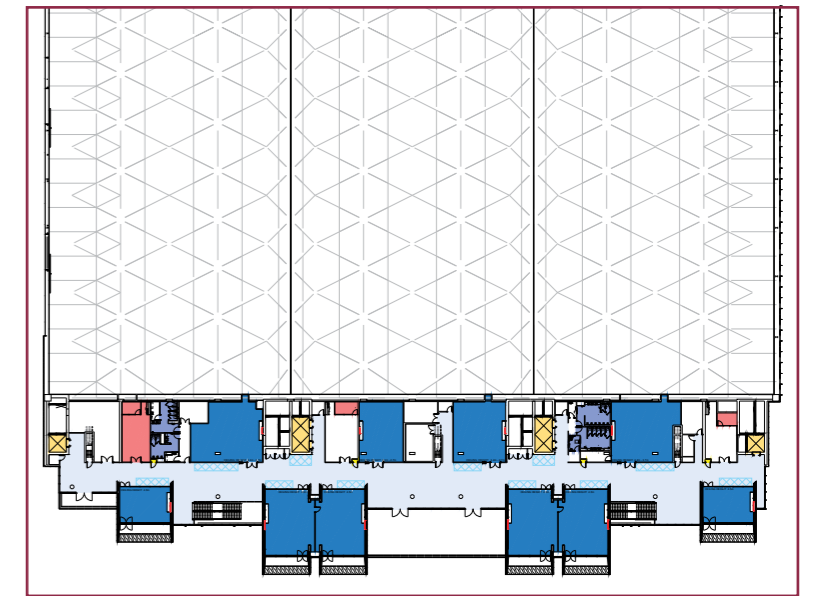
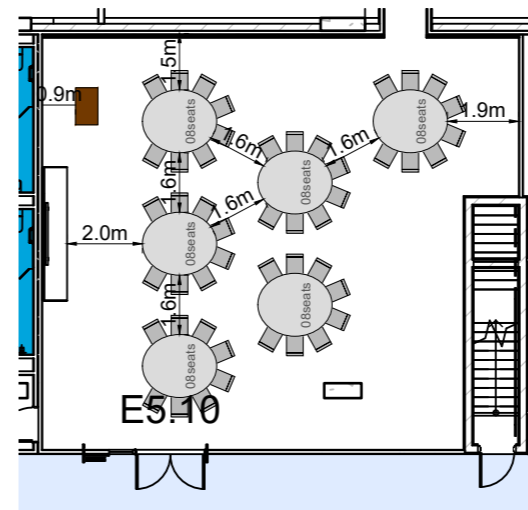
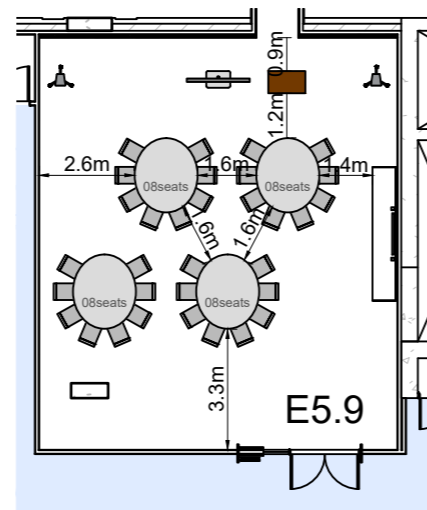
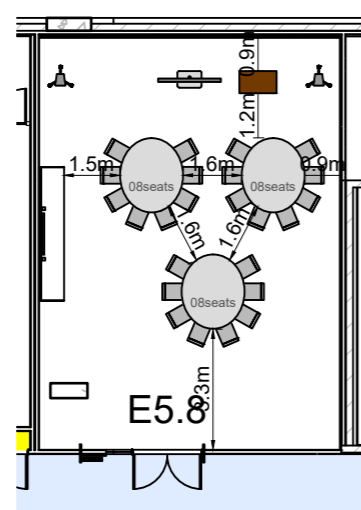
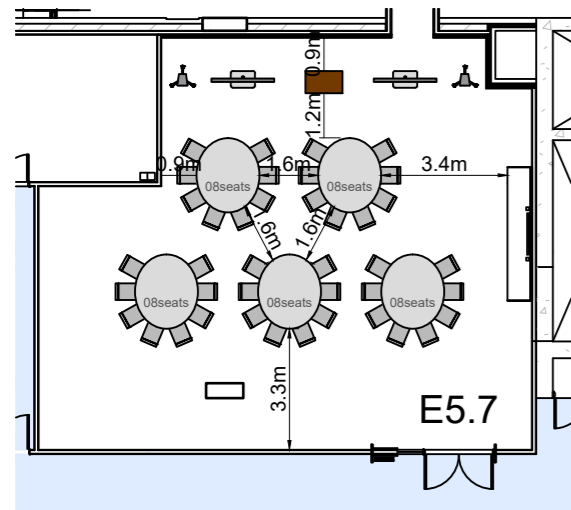

Level 5 Exhibition Centre

LEGEND

- Circulation Front of house
- Circulation Back of house
- Lifts
- Fire hydrant
- Toilets / facilities
- Organiser's offices and Suites
- Public Space Build Zone

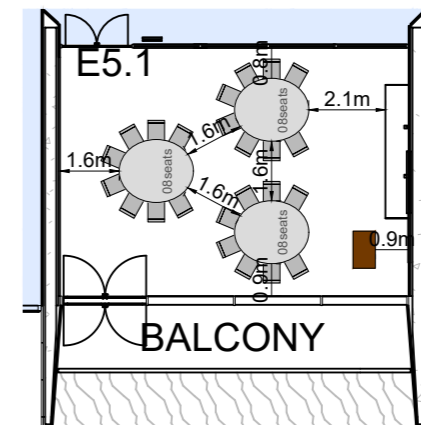
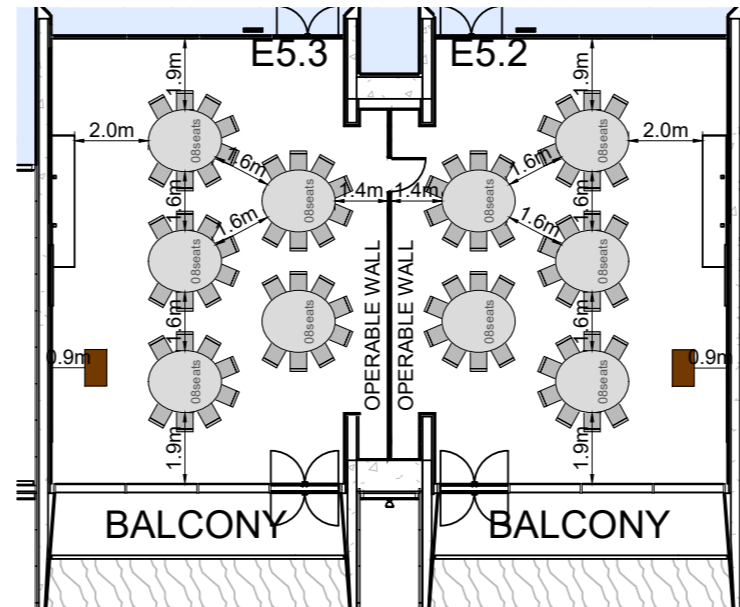
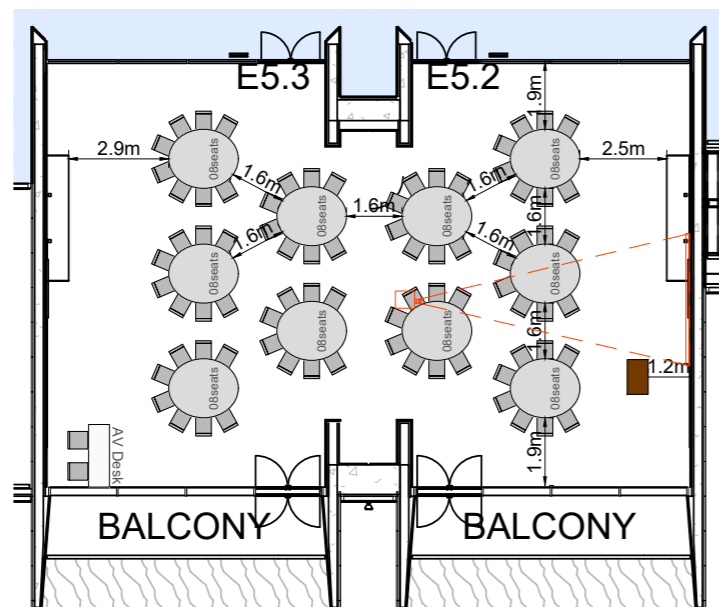
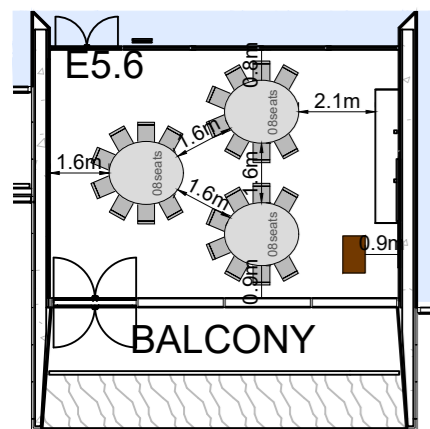

ROOM NAME	CABARET
MEETING ROOM E5.1	24
MEETING ROOM E5.2	40
MEETING ROOM E5.3	40
MEETING ROOM E5.2 & E5.3	80
MEETING ROOM E5.4	40
MEETING ROOM E5.5	40
MEETING ROOM E5.4 & E5.5	80
MEETING ROOM E5.6	24
MEETING ROOM E5.7	40
MEETING ROOM E5.8	24
MEETING ROOM E5.9	32
MEETING ROOM E5.10	48

* Standard capacity illustrated. Higher capacities can be achieved with less staging and AV services and reduced furniture spacing. Please consider your event requirements when viewing capacities.

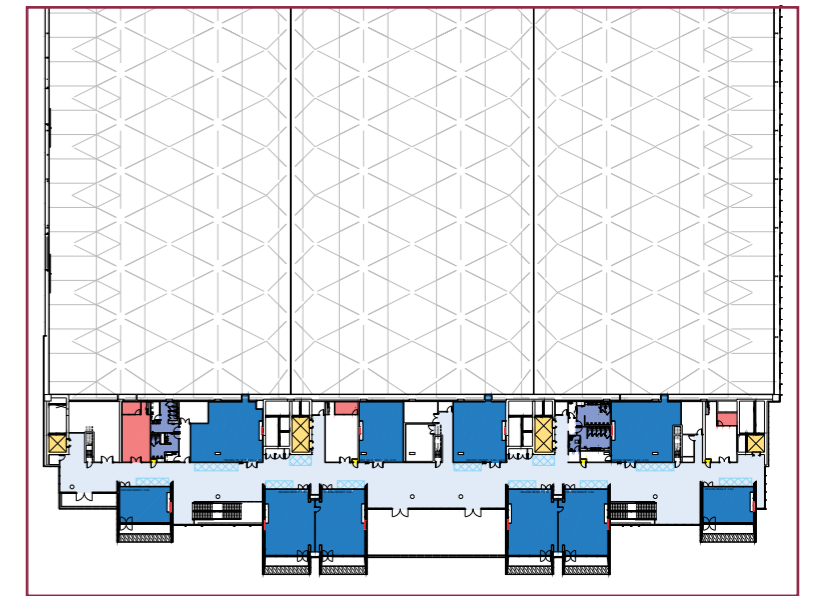
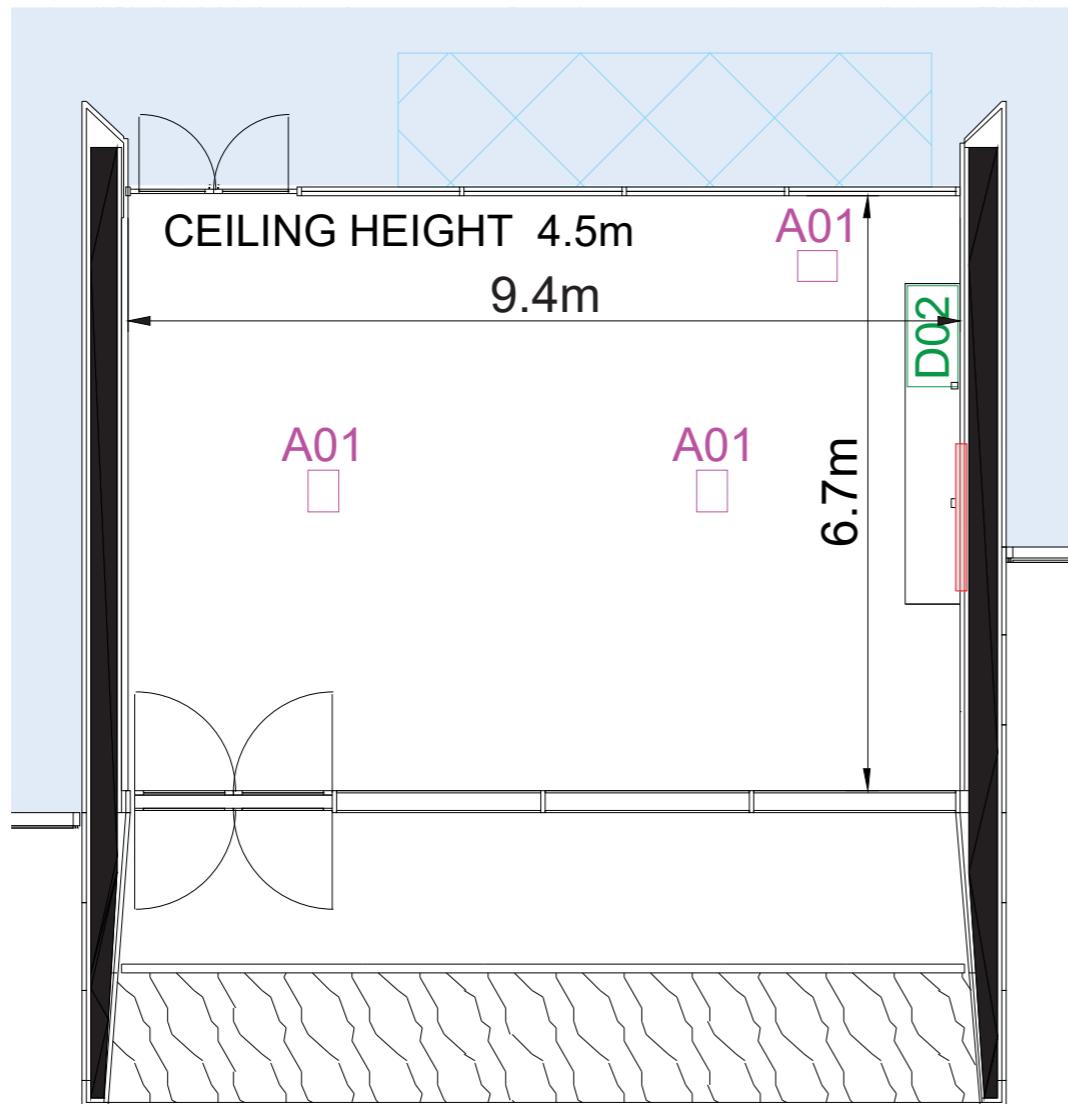

Level 5 Exhibition Centre

LEGEND

- A01** Floor Box Type A01
6 x SGPO
2 x SINGLE DATA
2 x SINGLE DATA SUPPLIED AND INSTALLED BY AV CONTRACTOR
- A04** Floor Box Type A04
3 x SGPO
2 x SINGLE DATA
- D01** Service Cupboard 01
2 x DGPO
1 x 32A 3PH
4 x SINGLE DATA
1 x 6C SMOF
WATER / WASTE
(BY HYDRAULIC CONTRACTOR)
- D02** Service Cupboard 02
2 x DGPO
1 x 32A 3PH
4 x SINGLE DATA
1 x 6C SMOF
- D06** Service Cupboard 06
1 x DGPO
1 x 20A SGPO
2 x SINGLE DATA
- Circulation Front of house
- Public Space Build Zone

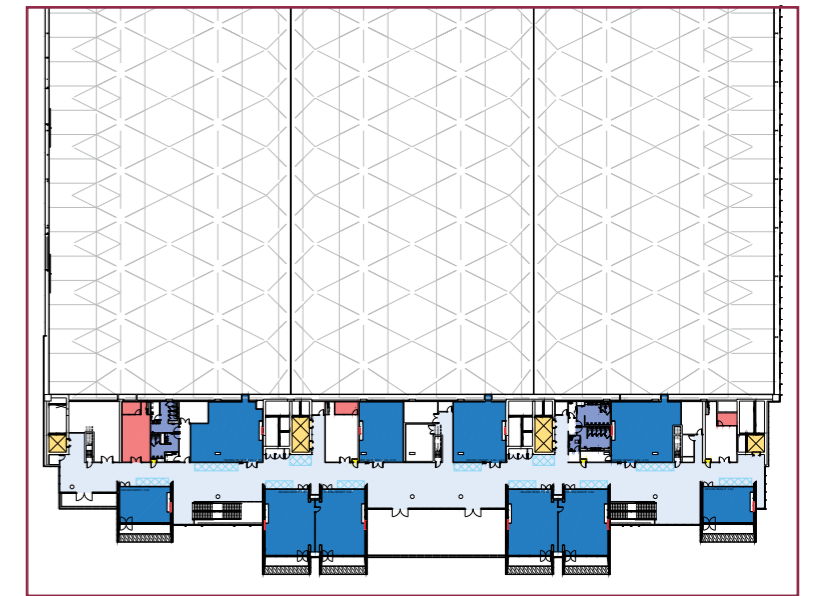
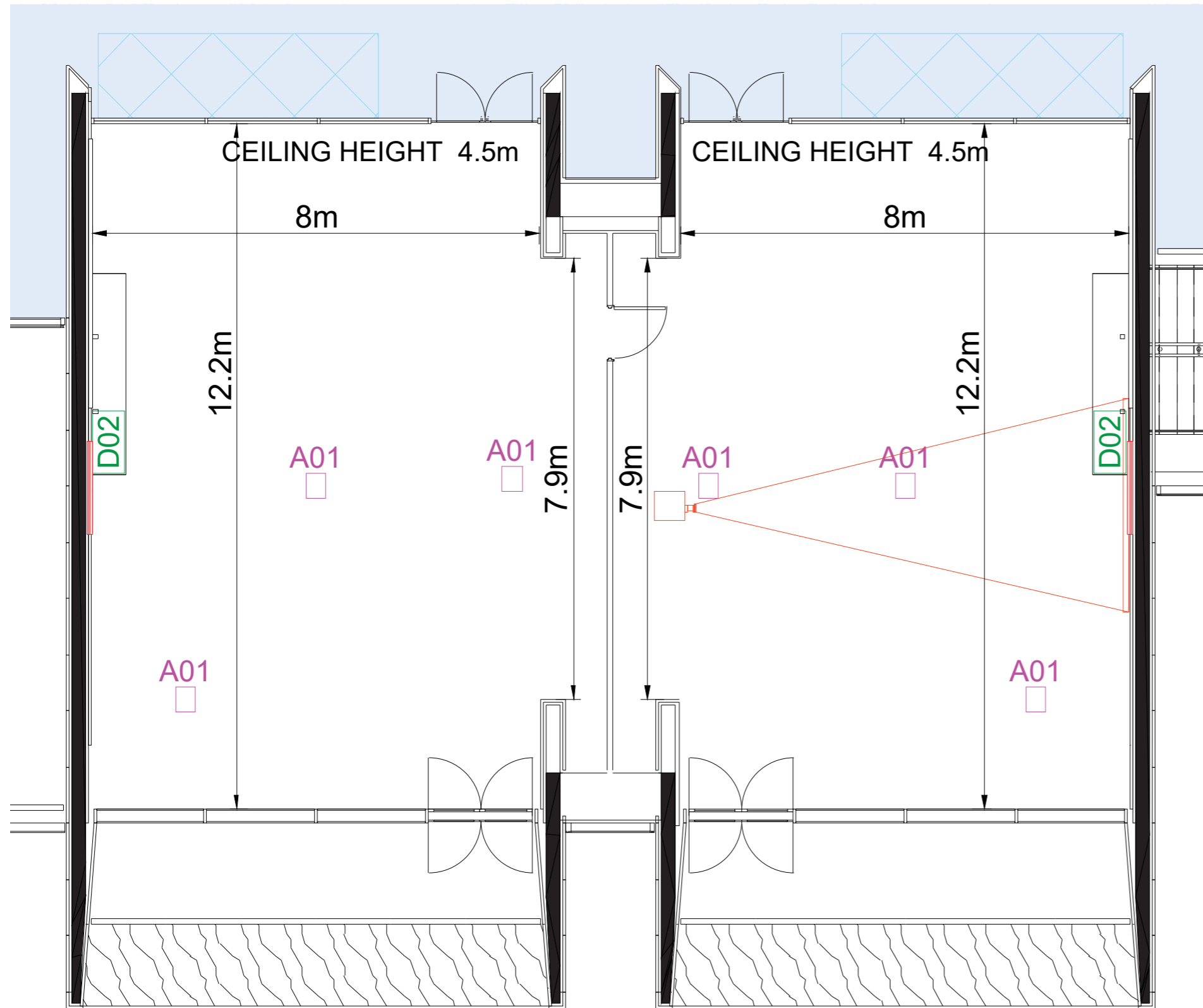

Level 5 Exhibition Centre

LEGEND

- **A01** Floor Box Type A01
6 x SGPO
2 x SINGLE DATA
2 x SINGLE DATA SUPPLIED AND INSTALLED BY AV CONTRACTOR
- **A04** Floor Box Type A04
3 x SGPO
2 x SINGLE DATA
- **D01** Service Cupboard 01
2 x DGPO
1 x 32A 3PH
4 x SINGLE DATA
1 x 6C SMOF
WATER / WASTE
(BY HYDRAULIC CONTRACTOR)
- **D02** Service Cupboard 02
2 x DGPO
1 x 32A 3PH
4 x SINGLE DATA
1 x 6C SMOF
- **D06** Service Cupboard 06
1 x DGPO
1 x 20A SGPO
2 x SINGLE DATA
- Circulation Front of house
- Public Space Build Zone

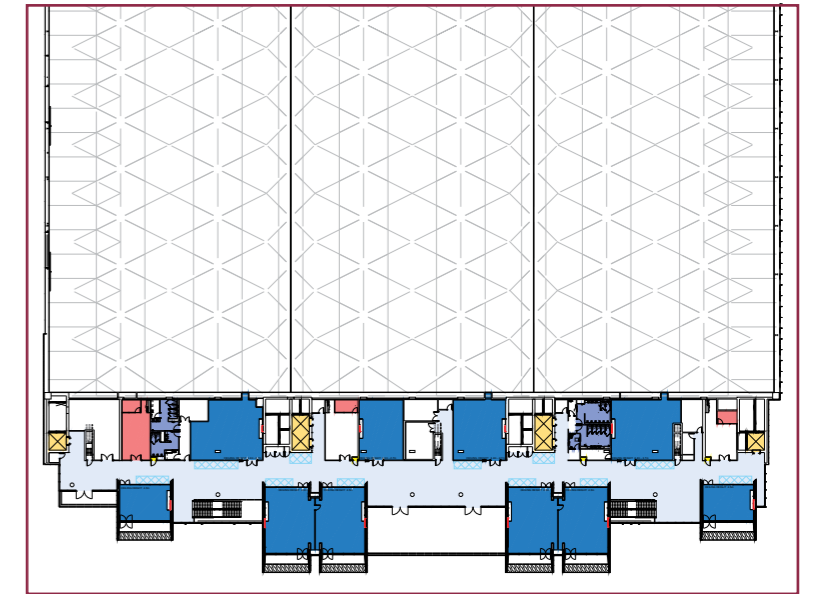
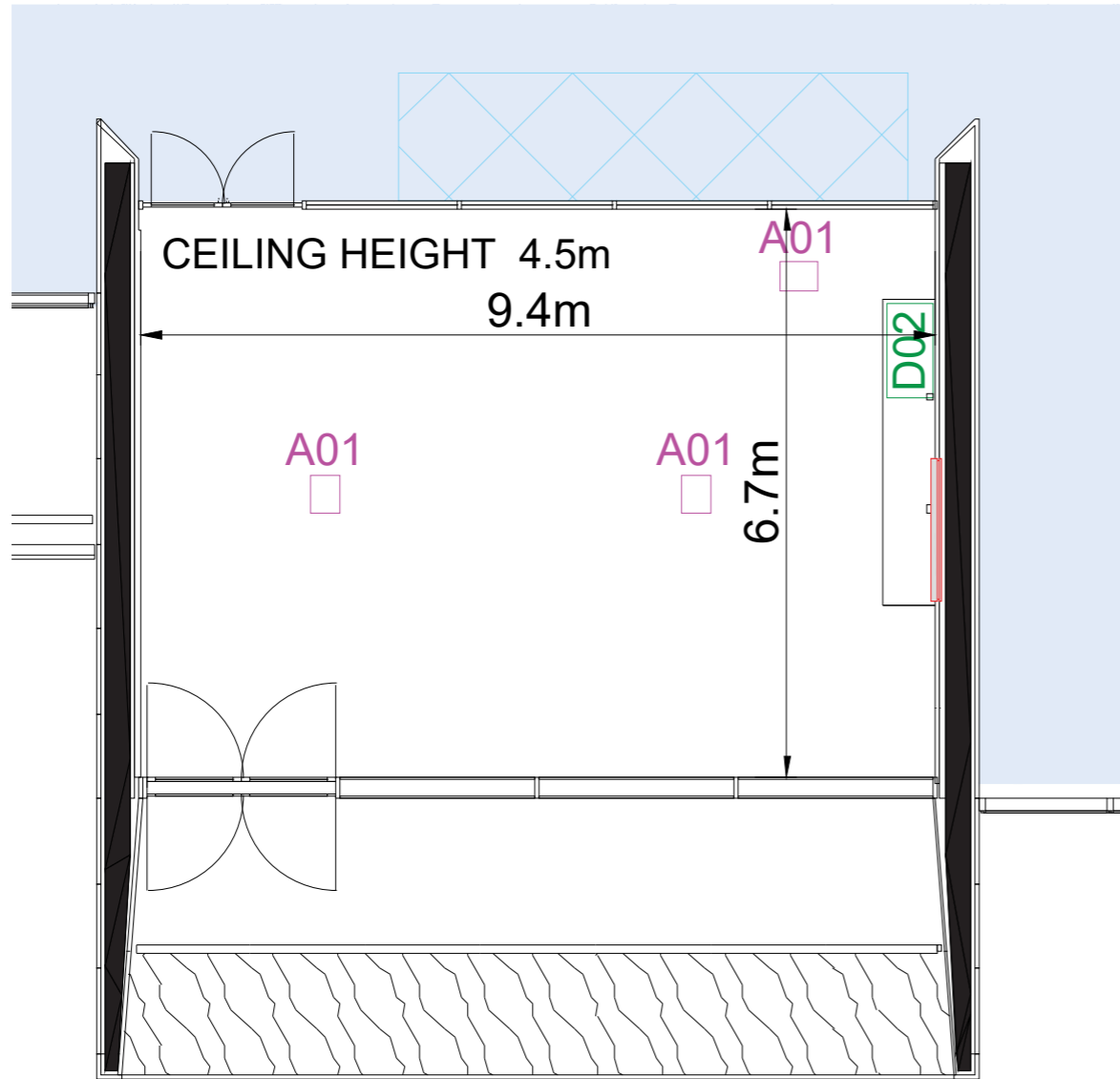

Level 5 Exhibition Centre

LEGEND

- A01** Floor Box Type A01
6 x SGPO
2 x SINGLE DATA
2 x SINGLE DATA SUPPLIED AND INSTALLED BY AV CONTRACTOR
- A04** Floor Box Type A04
3 x SGPO
2 x SINGLE DATA
- D01** Service Cupboard 01
2 x DGPO
1 x 32A 3PH
4 x SINGLE DATA
1 x 6C SMOF
WATER / WASTE
(BY HYDRAULIC CONTRACTOR)
- D02** Service Cupboard 02
2 x DGPO
1 x 32A 3PH
4 x SINGLE DATA
1 x 6C SMOF
- D06** Service Cupboard 06
1 x DGPO
1 x 20A SGPO
2 x SINGLE DATA
- Circulation Front of house
- Public Space Build Zone

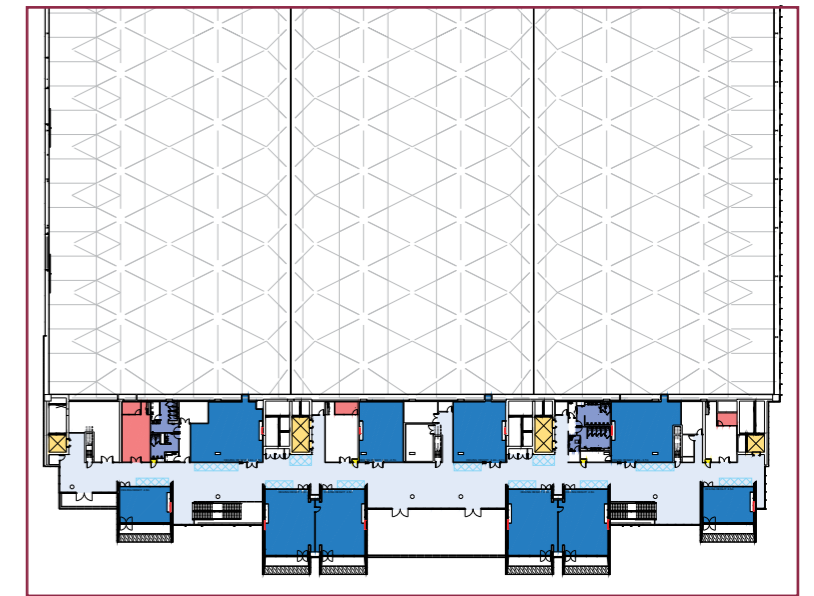
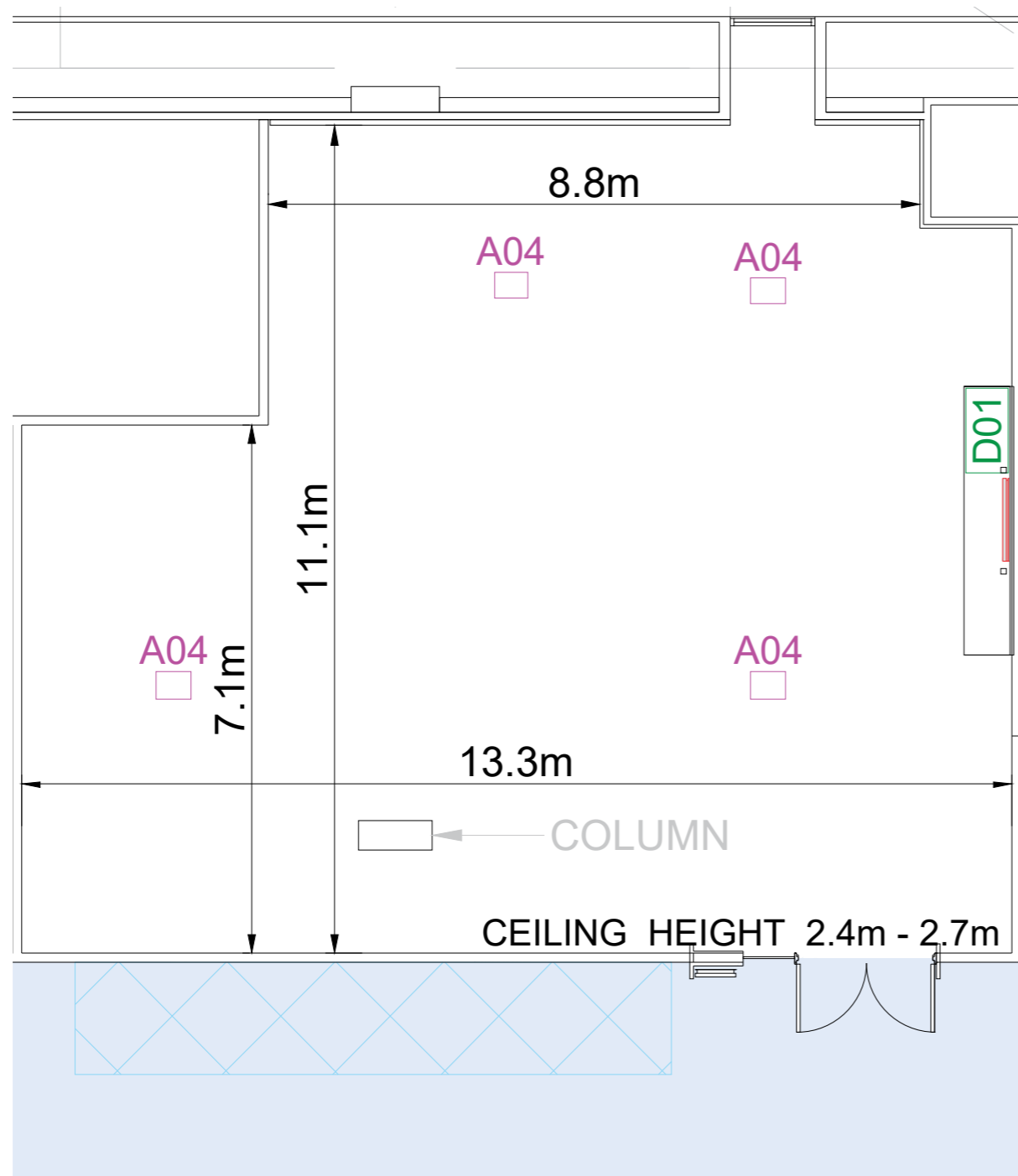

Level 5 Exhibition Centre

LEGEND

- A01** Floor Box Type A01
6 x SGPO
2 x SINGLE DATA
2 x SINGLE DATA SUPPLIED AND INSTALLED BY AV CONTRACTOR
- A04** Floor Box Type A04
3 x SGPO
2 x SINGLE DATA
- D01** Service Cupboard 01
2 x DGPO
1 x 32A 3PH
4 x SINGLE DATA
1 x 6C SMOF
WATER / WASTE
(BY HYDRAULIC CONTRACTOR)
- D02** Service Cupboard 02
2 x DGPO
1 x 32A 3PH
4 x SINGLE DATA
1 x 6C SMOF
- D06** Service Cupboard 06
1 x DGPO
1 x 20A SGPO
2 x SINGLE DATA
- Circulation Front of house
- Public Space Build Zone

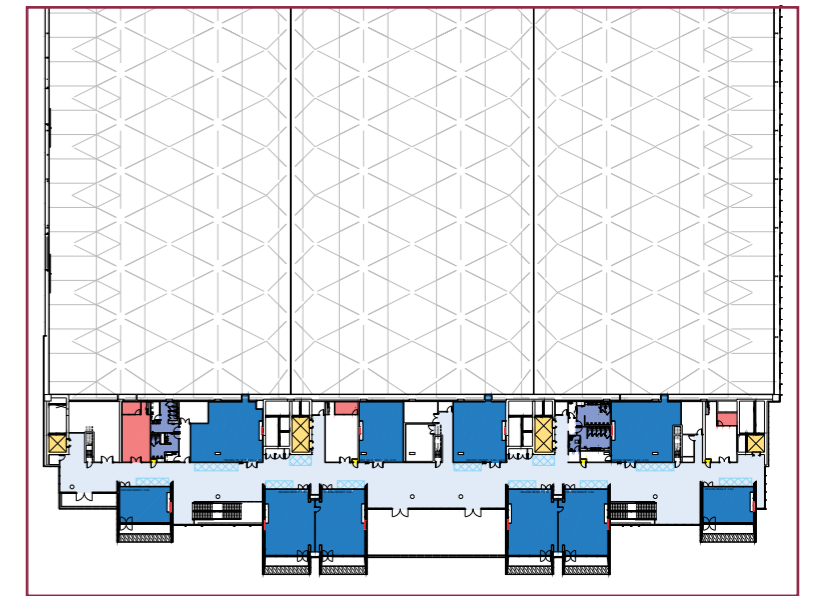
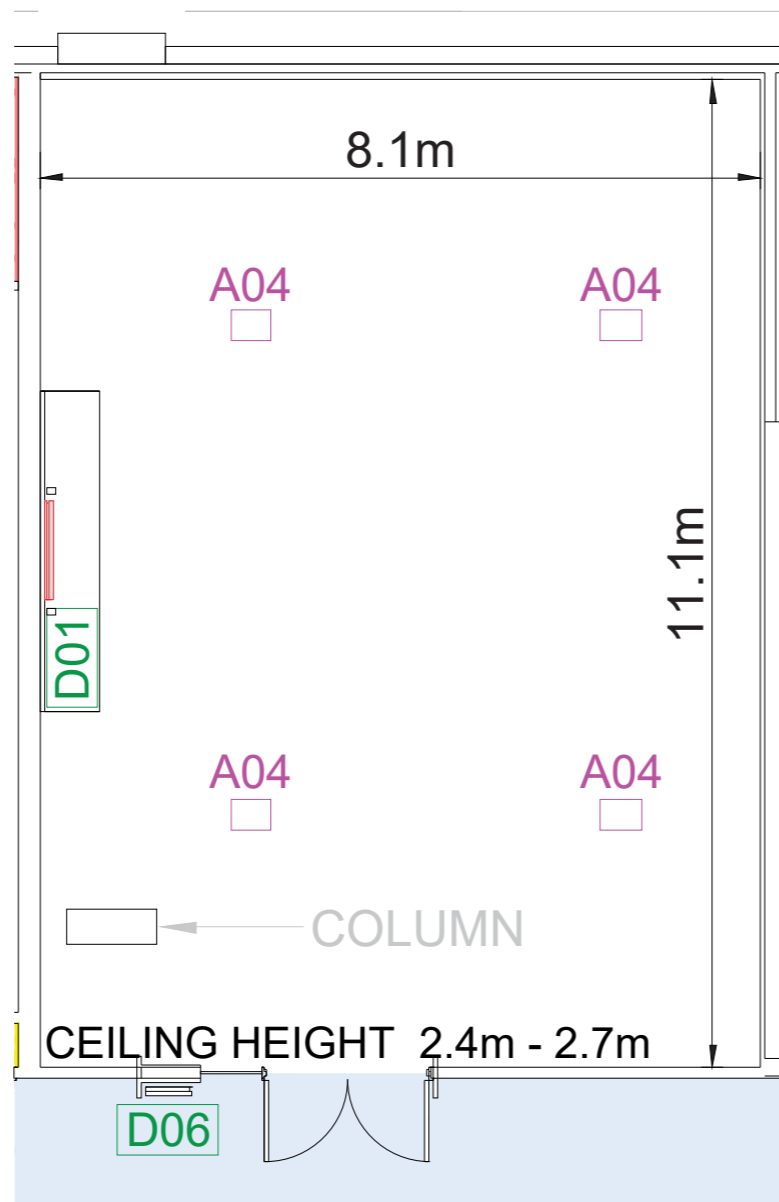

Level 5 Exhibition Centre

LEGEND

- A01** Floor Box Type A01
6 x SGPO
2 x SINGLE DATA
2 x SINGLE DATA SUPPLIED AND INSTALLED BY AV CONTRACTOR
- A04** Floor Box Type A04
3 x SGPO
2 x SINGLE DATA
- D01** Service Cupboard 01
2 x DGPO
1 x 32A 3PH
4 x SINGLE DATA
1 x 6C SMOF
WATER / WASTE
(BY HYDRAULIC CONTRACTOR)
- D02** Service Cupboard 02
2 x DGPO
1 x 32A 3PH
4 x SINGLE DATA
1 x 6C SMOF
- D06** Service Cupboard 06
1 x DGPO
1 x 20A SGPO
2 x SINGLE DATA
- Circulation Front of house
- Public Space Build Zone

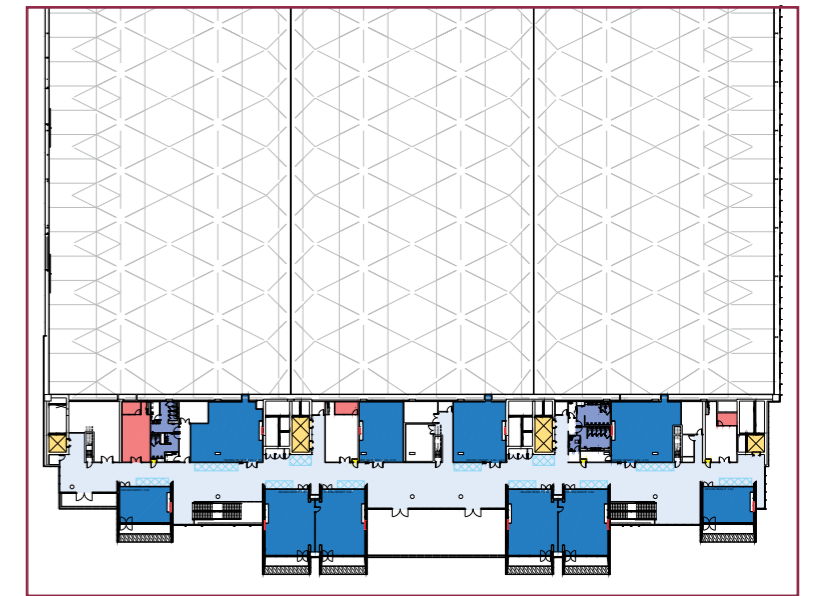
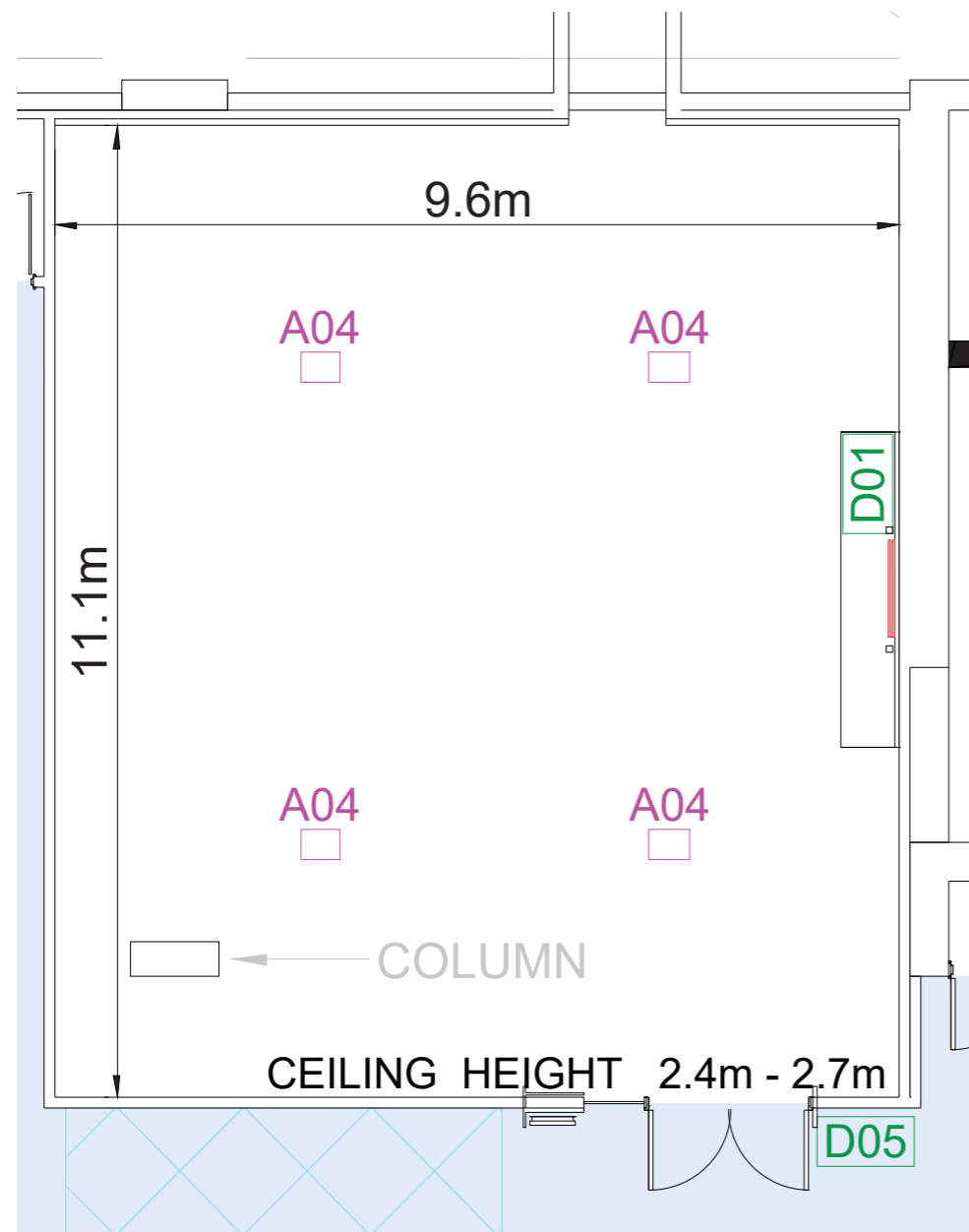

Level 5 Exhibition Centre

LEGEND

- A01** Floor Box Type A01
6 x SGPO
2 x SINGLE DATA
2 x SINGLE DATA SUPPLIED AND INSTALLED BY AV CONTRACTOR
- A04** Floor Box Type A04
3 x SGPO
2 x SINGLE DATA
- D01** Service Cupboard 01
2 x DGPO
1 x 32A 3PH
4 x SINGLE DATA
1 x 6C SMOF
WATER / WASTE
(BY HYDRAULIC CONTRACTOR)
- D02** Service Cupboard 02
2 x DGPO
1 x 32A 3PH
4 x SINGLE DATA
1 x 6C SMOF
- D06** Service Cupboard 06
1 x DGPO
1 x 20A SGPO
2 x SINGLE DATA
- Circulation Front of house
- Public Space Build Zone

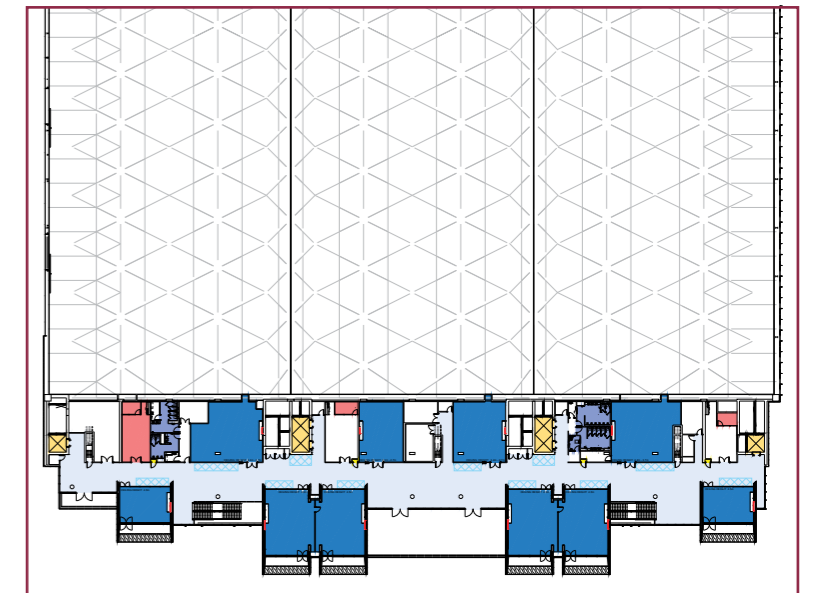
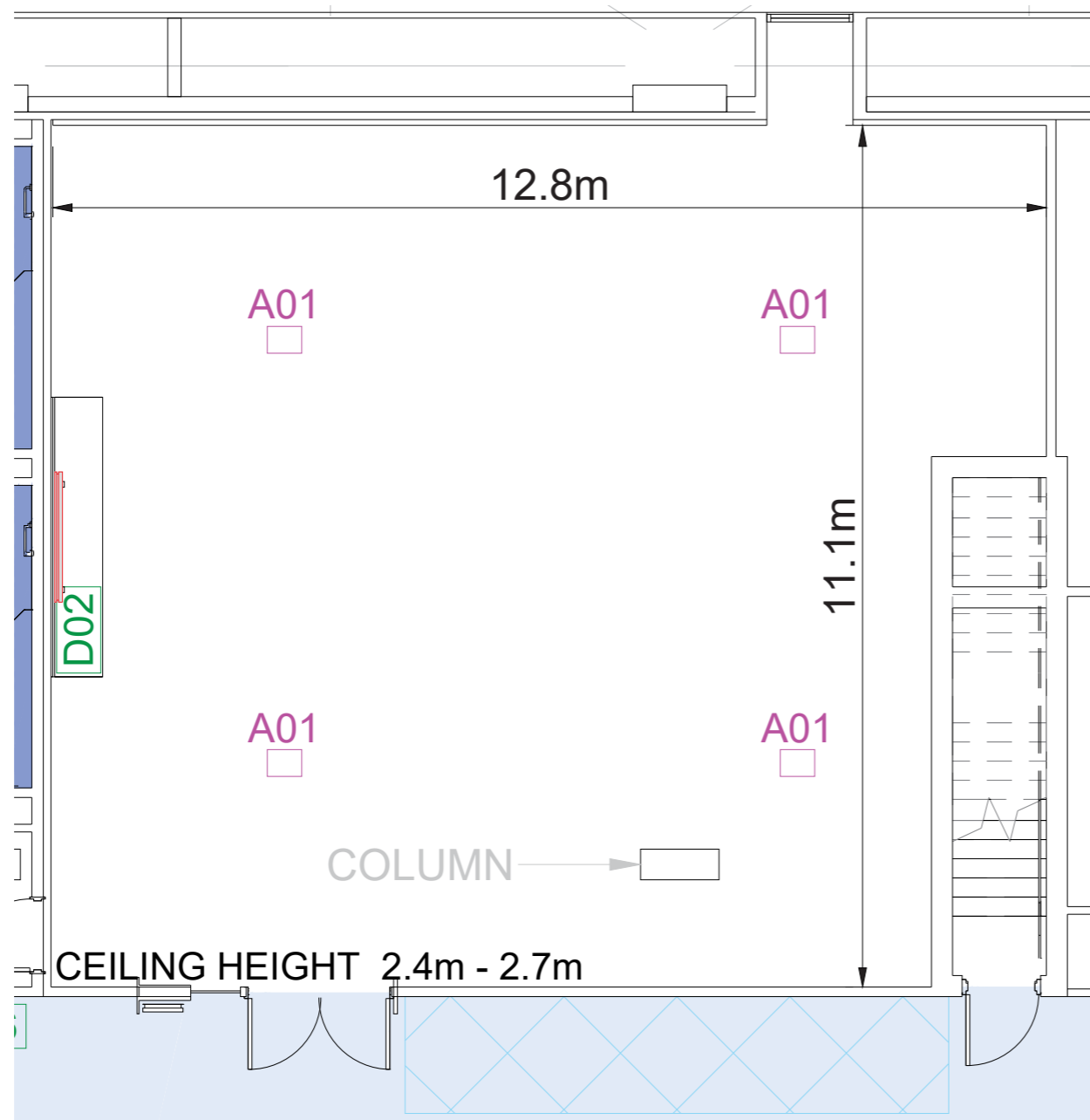

Level 5 Exhibition Centre

LEGEND

- A01** Floor Box Type A01
6 x SGPO
2 x SINGLE DATA
2 x SINGLE DATA SUPPLIED AND INSTALLED BY AV CONTRACTOR
- A04** Floor Box Type A04
3 x SGPO
2 x SINGLE DATA
- D01** Service Cupboard 01
2 x DGPO
1 x 32A 3PH
4 x SINGLE DATA
1 x 6C SMOF
WATER / WASTE
(BY HYDRAULIC CONTRACTOR)
- D02** Service Cupboard 02
2 x DGPO
1 x 32A 3PH
4 x SINGLE DATA
1 x 6C SMOF
- D06** Service Cupboard 06
1 x DGPO
1 x 20A SGPO
2 x SINGLE DATA
- Circulation Front of house
- Public Space Build Zone

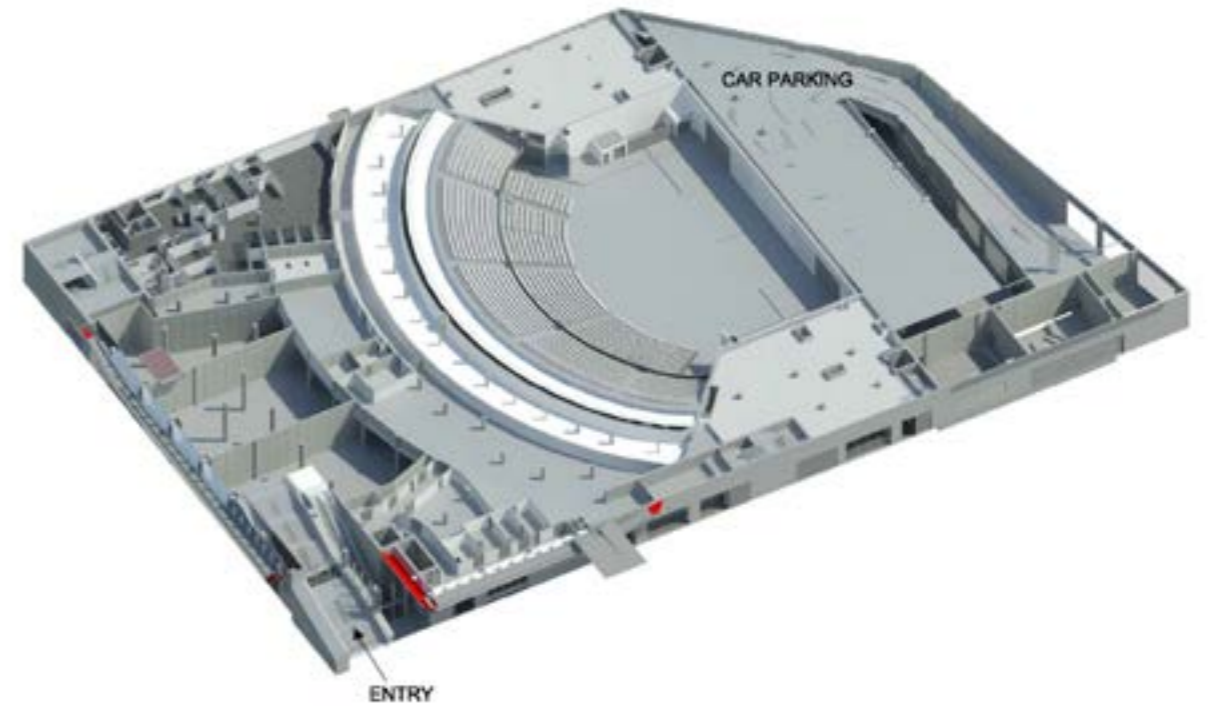
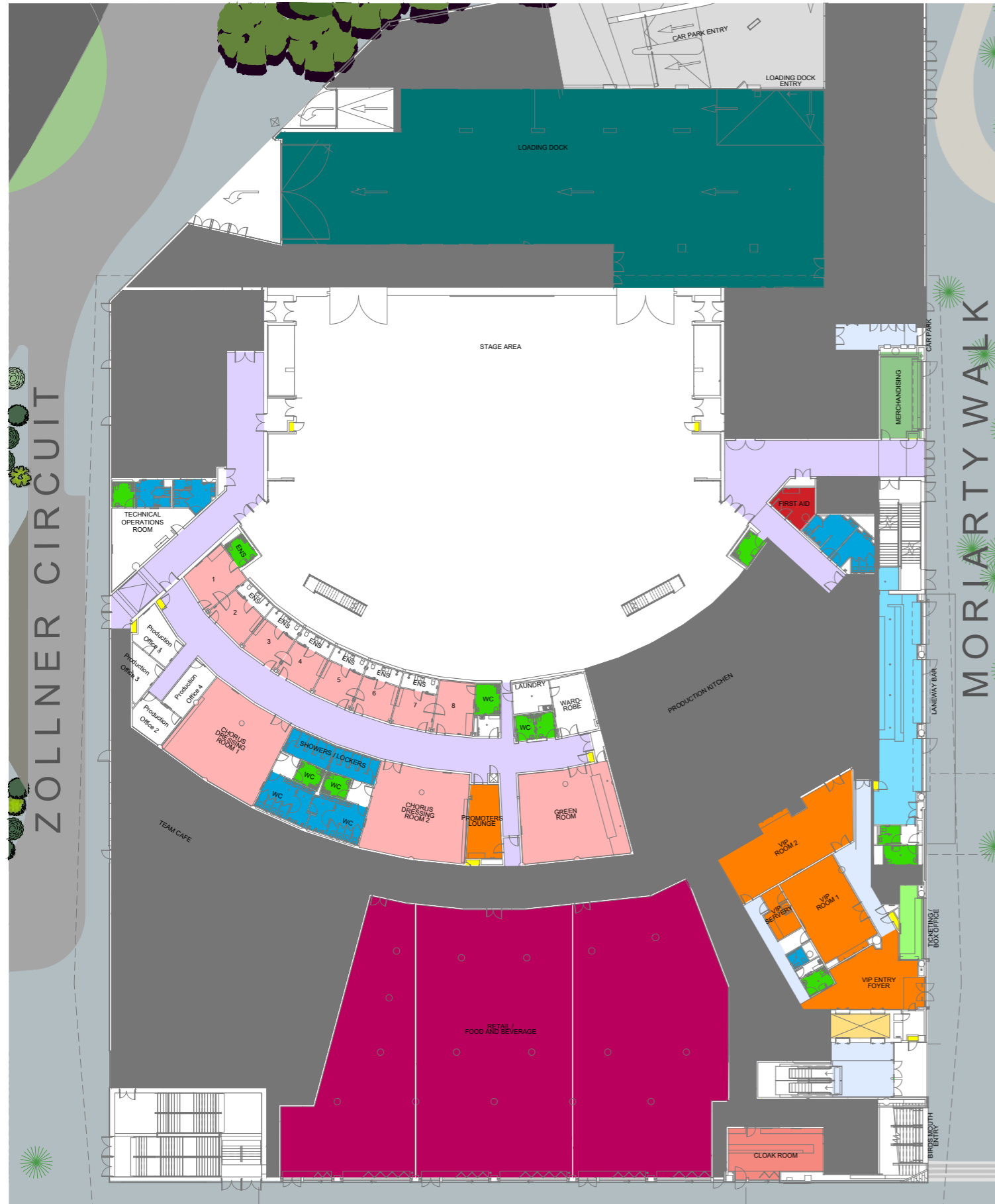

LEGEND

- Circulation front of house
- Circulation back of house
- VIP facilities
- Dressing rooms / Green Room
- Laneway Bar
- Cloak room
- Merchandise outlet
- Ticketing / Box office
- Toilets / Facilities
- Accessible Toilet
- First Aid
- Loading Dock
- Lifts
- Fire Hydrants

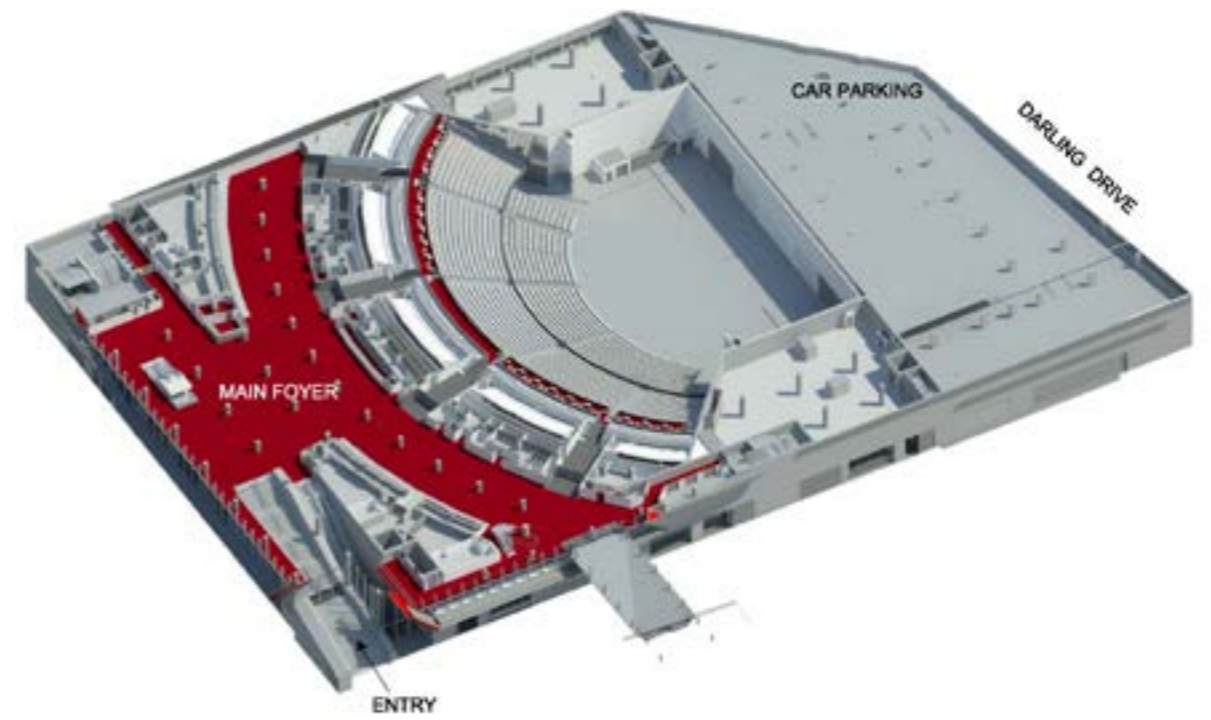
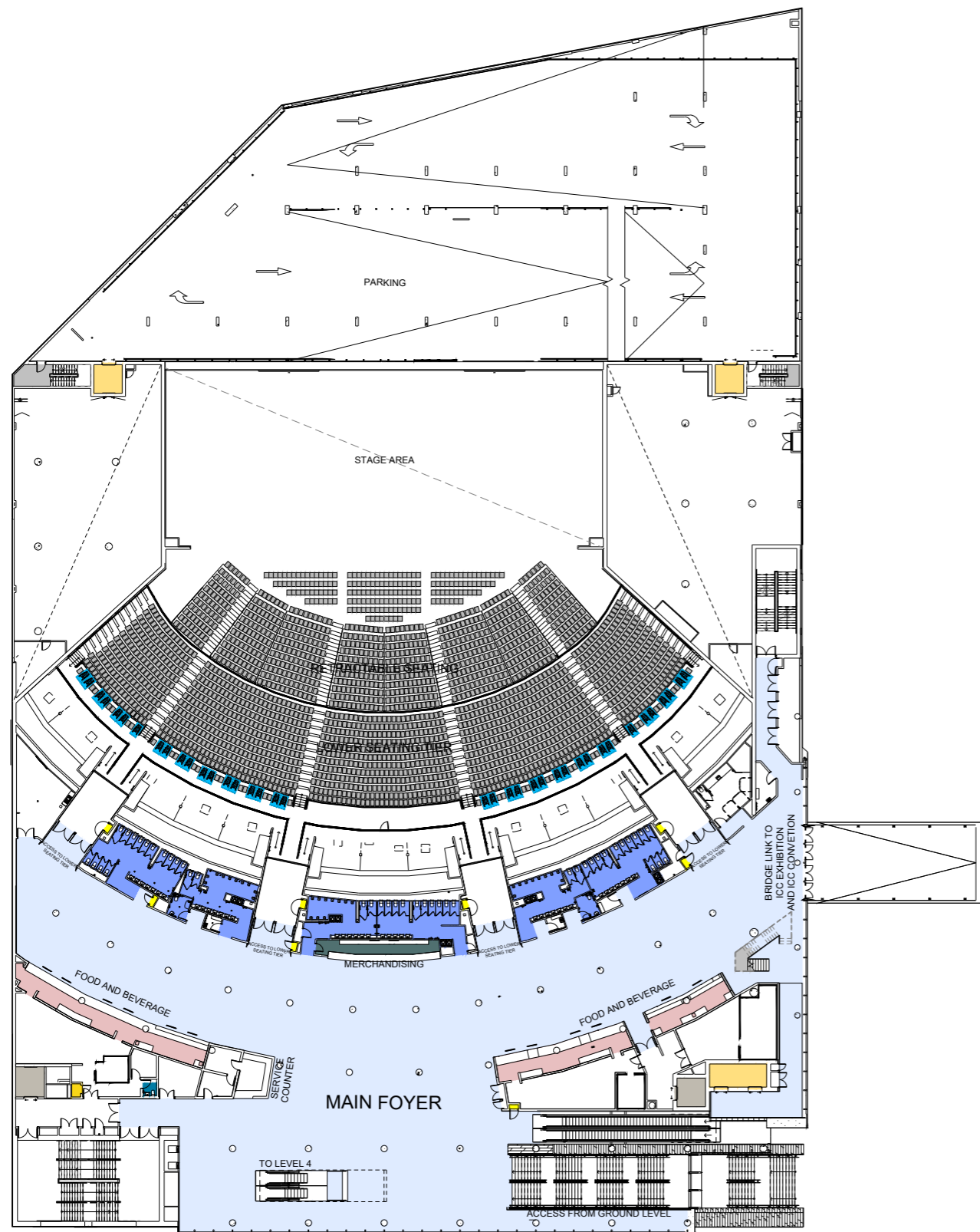

LEGEND

- Circulation front of house / Main Foyer
- Food and beverage
- Merchandising
- Toilets / facilities
- Lifts

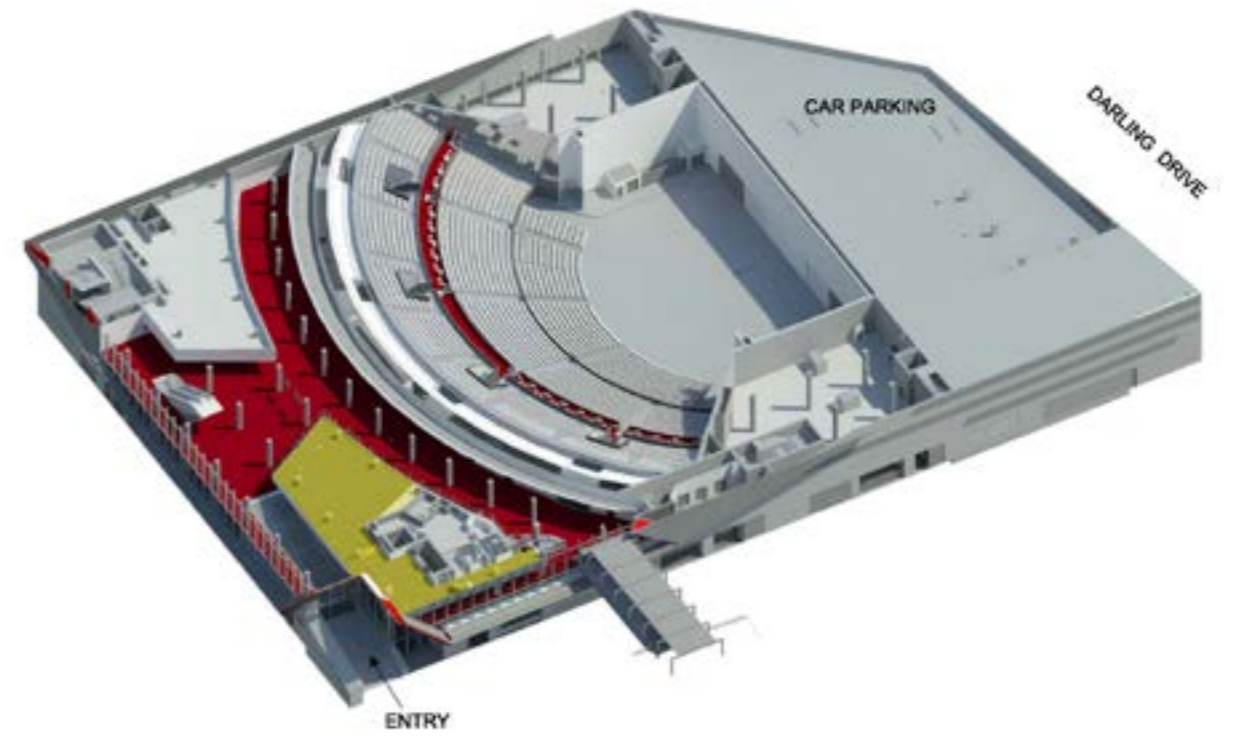
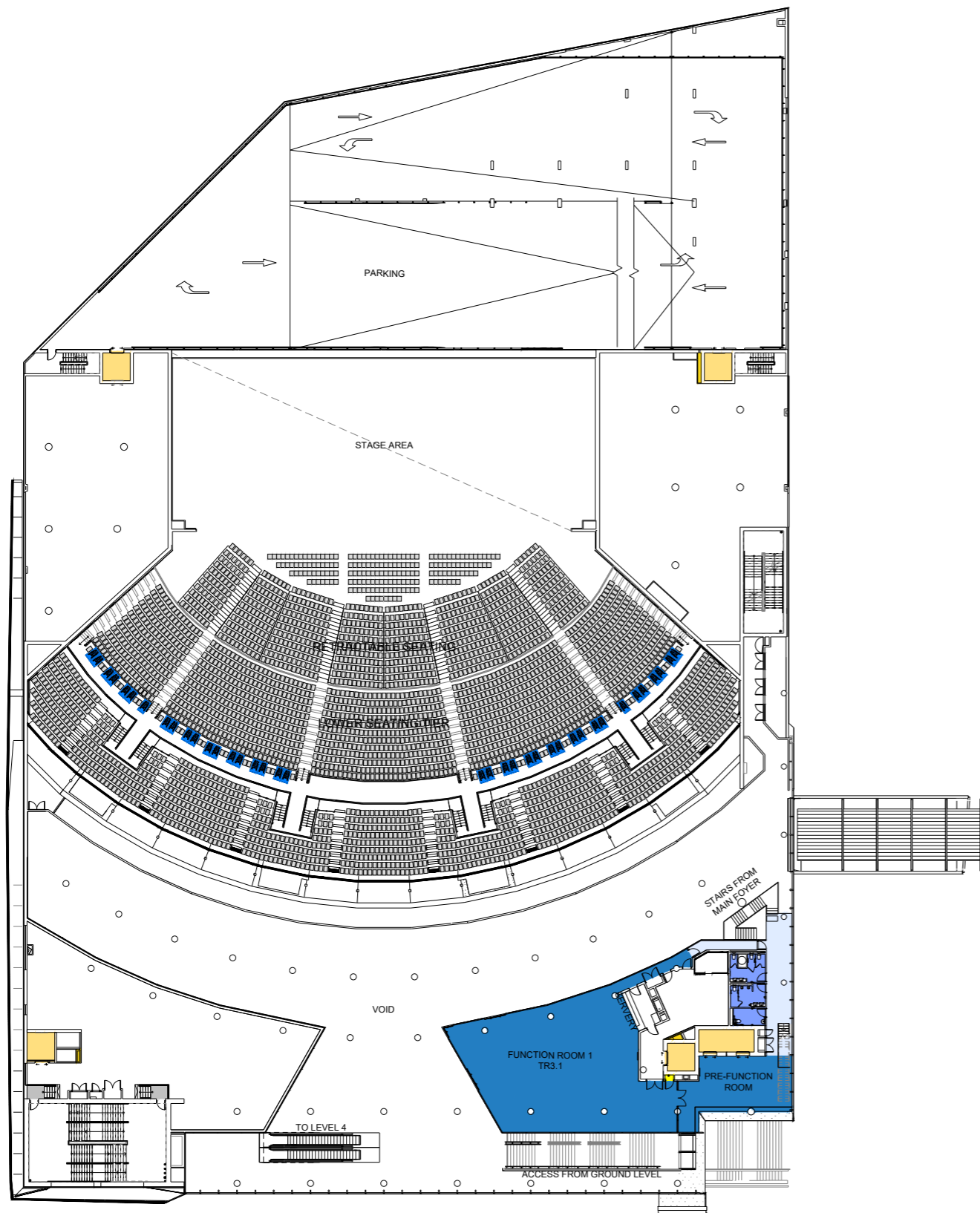

LEGEND

- Circulation front of house
- Function Room TR3.1
- Toilets / facilities
- Lifts

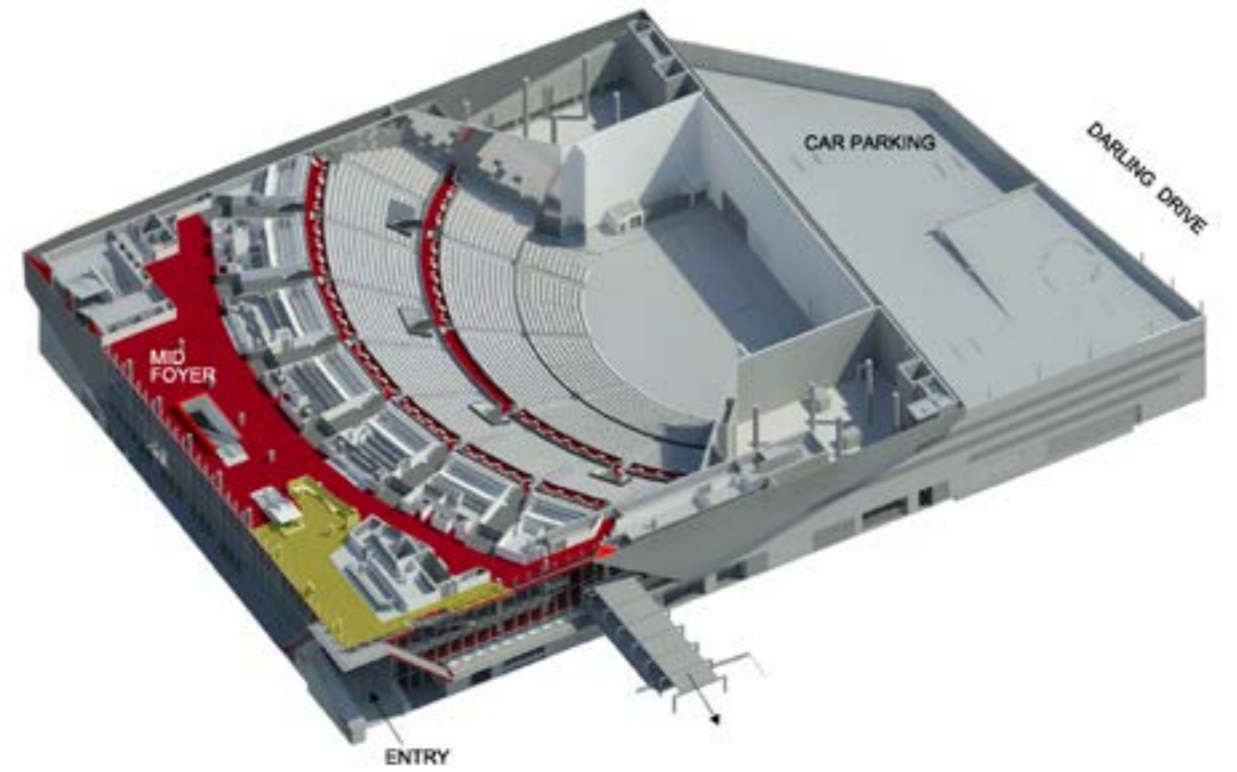
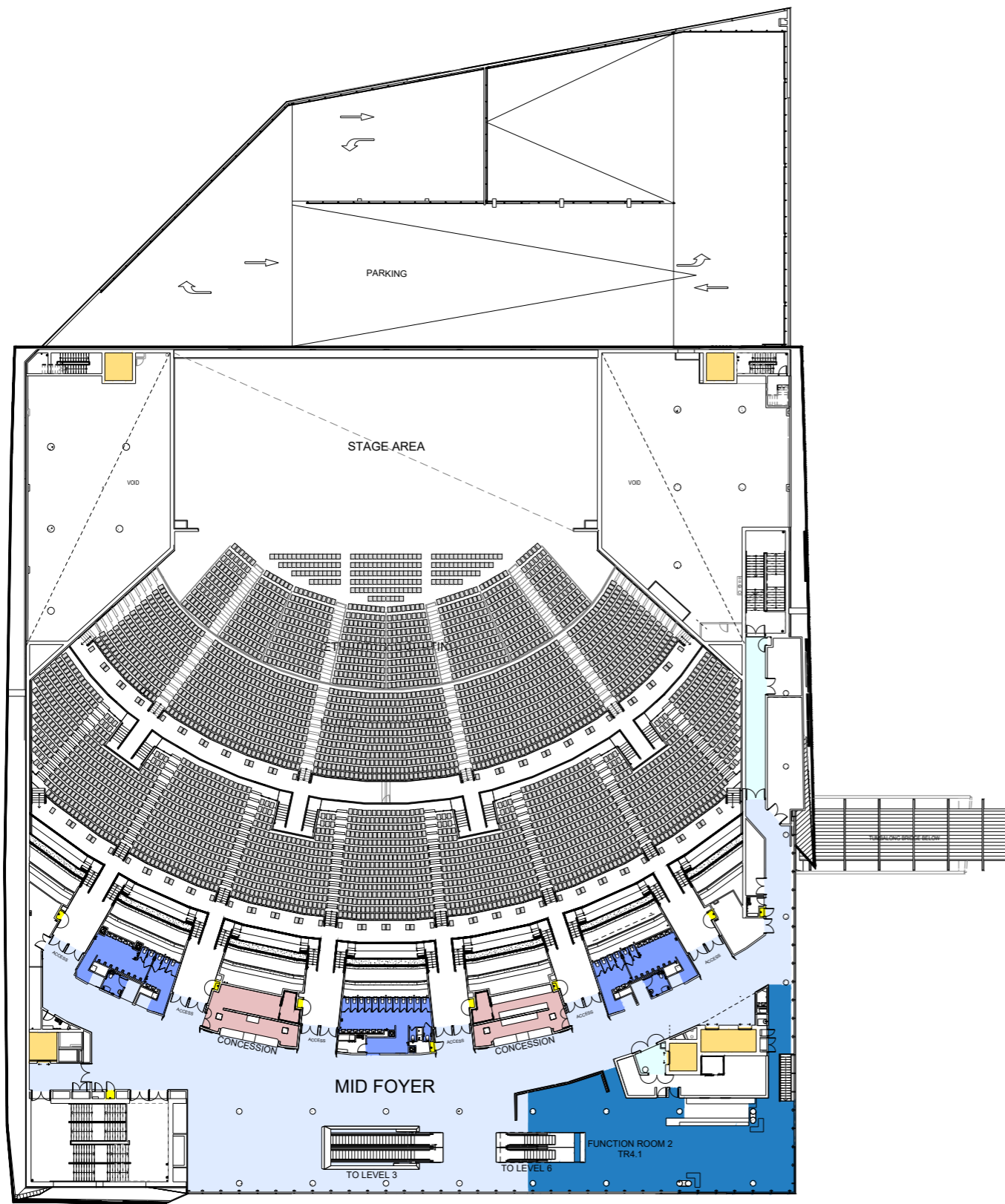

LEGEND

- Circulation front of house / Mid Foyer
- Function Room 2 TR4.1
- Concessions
- Toilets / facilities
- Lifts

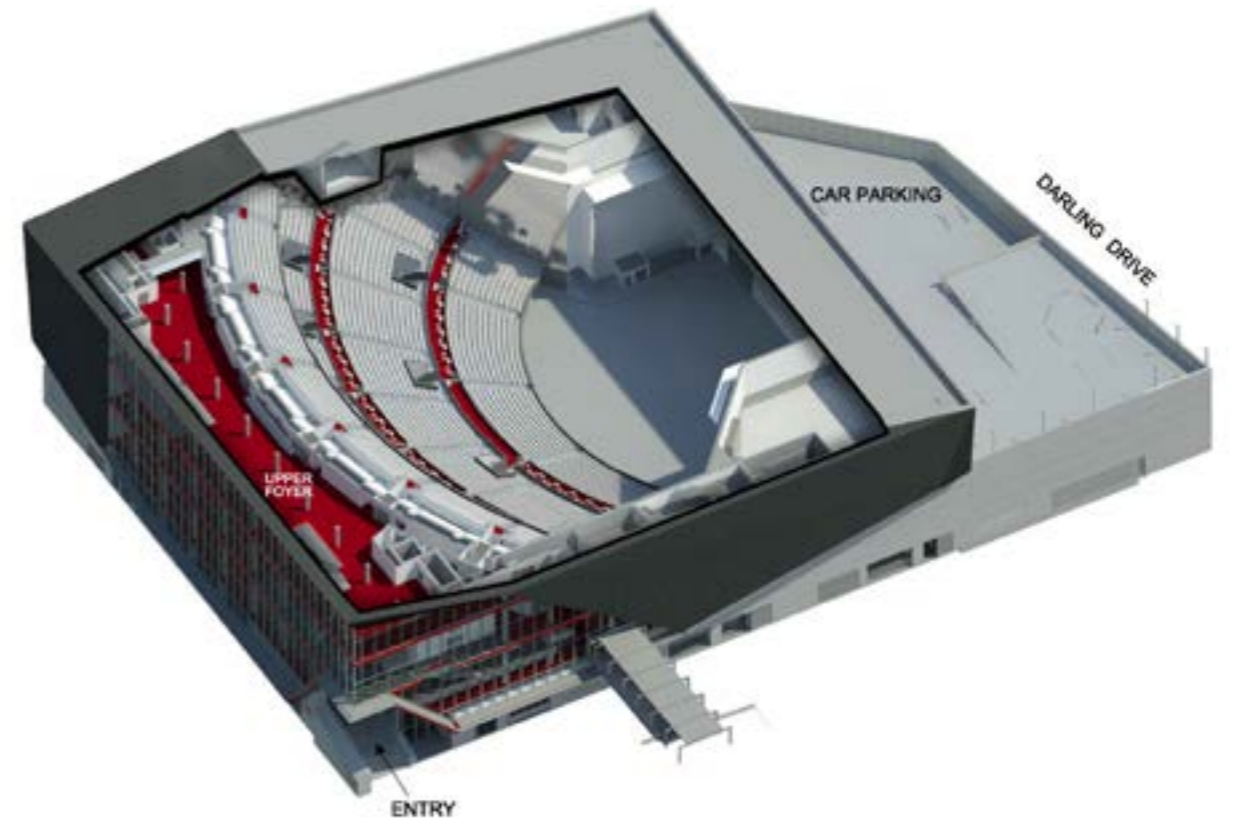
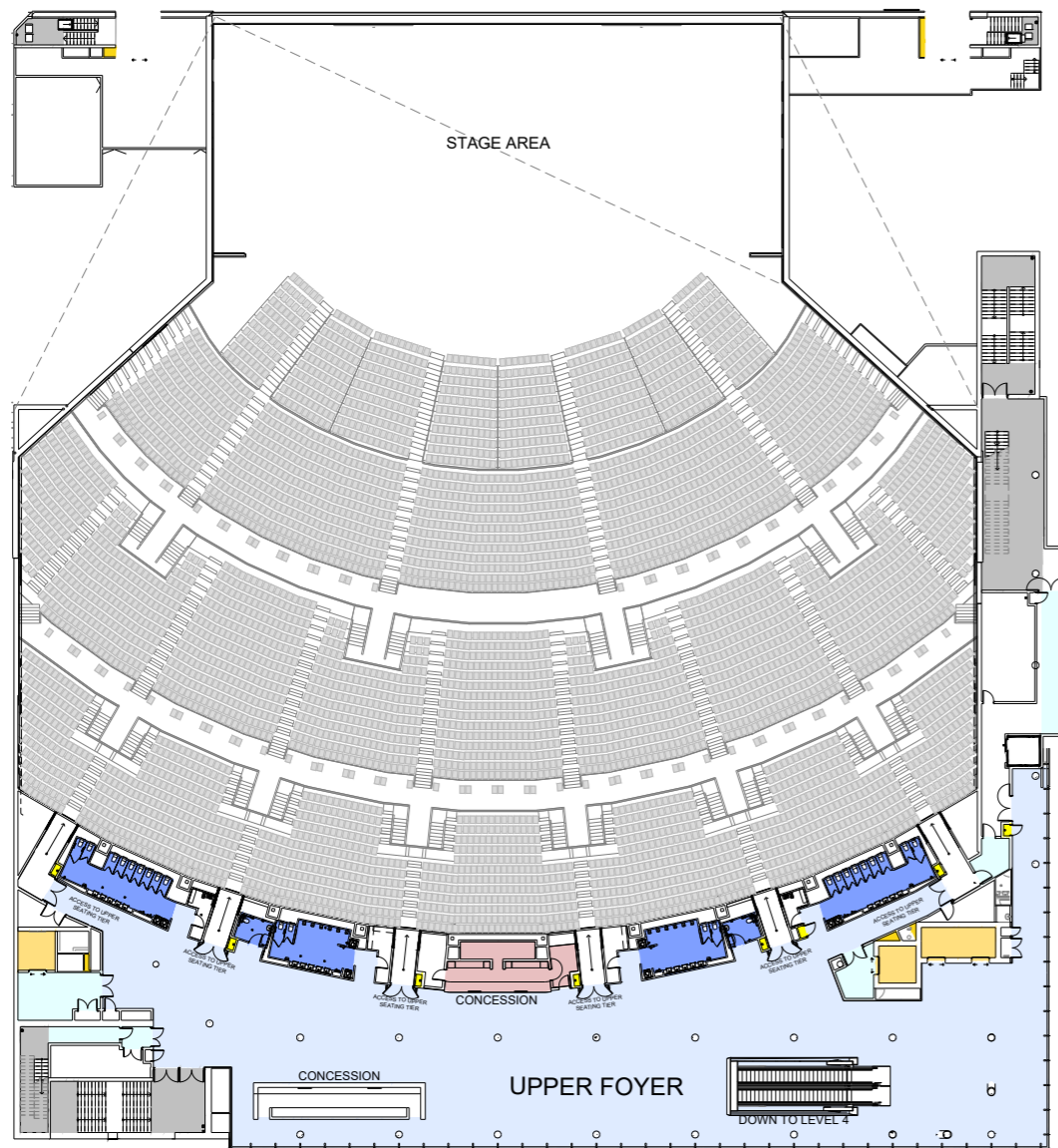

LEGEND

- Circulation front of house / Upper Foyer
- Food and beverage
- Toilets / facilities
- Lifts
- Fire Hydrant

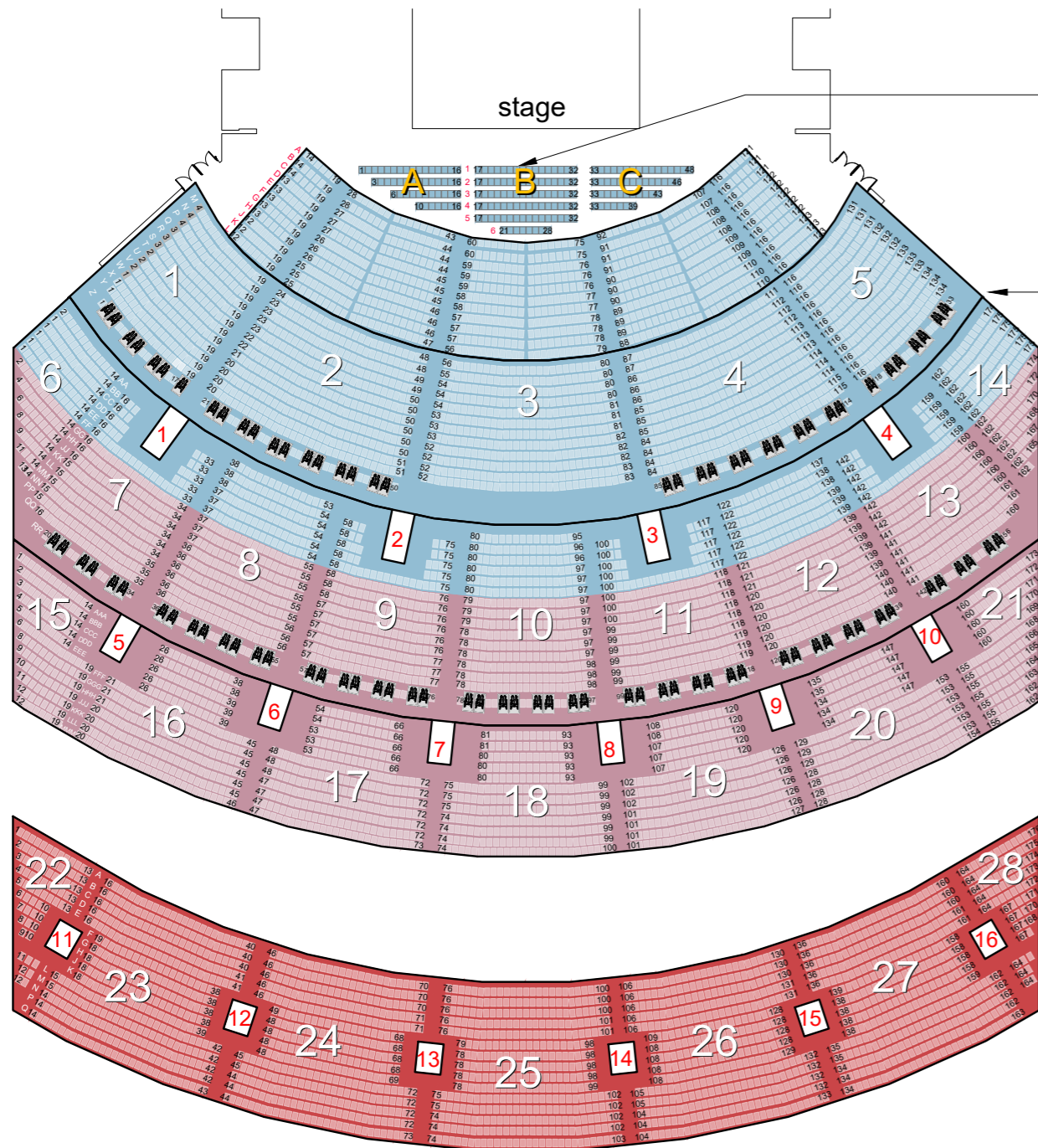

LEVEL 2
FLOOR SEATING
ENTER VIA DOORS
1 - 4

LEVEL 2
DOORS 1 - 4
SECTION 1 - 5
SECTION 6 - 10 ROWS AA - FF

LEVEL 4
DOORS 5 - 10
SECTION 6 - 14 ROWS GG - RR
SECTION 15 - 21

LEVEL 6
DOORS 11 - 16
SECTION 22 - 28

